

Mitsubishi Programmable Controller

MELSEC **Q** series

Temperature Control Module User's Manual

- Q64TCTT
- Q64TCTTBW
- Q64TCRT
- Q64TCRTBW
- GX Configurator-TC (SW0D5C-QTCU-E)

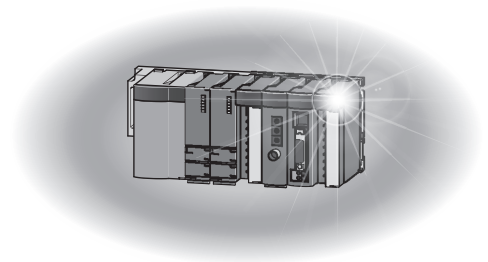

• SAFETY PRECAUTIONS •

(Read these precautions before using this product.)

Before using this product, please read this manual and the relevant manuals carefully and pay full attention to safety to handle the product correctly.

The instructions given in this manual are concerned with this product. For the safety instructions of the programmable controller system, please read the CPU module User's Manual.

In this manual, the safety precautions are classified into two levels: "⚠ WARNING " and "⚠ CAUTION".

 **WARNING**

Indicates that incorrect handling may cause hazardous conditions, resulting in death or severe injury.

 **CAUTION**

Indicates that incorrect handling may cause hazardous conditions, resulting in minor or moderate injury or property damage.

Under some circumstances, failure to observe the precautions given under "⚠ CAUTION" may lead to serious consequences.

Make sure that the end users read this manual and then keep the manual in a safe place for future reference.

[Design Precautions]

WARNING

- Do not write data into the "read-only area" in the buffer memory of the intelligent function module. In addition, do not turn on/off the "reserved" signals among the I/O signals transferred to/from the programmable controller CPU.
Doing so can malfunction the programmable controller system.
- Depending on the malfunction of the external output transistor, there may be cases where the output is on or off status. Install external monitoring circuitry for output signals that may lead to major accidents.

CAUTION

- Do not bunch the control wires or communication cables with the main circuit or power wires, or install them close to each other.
They should be installed 100 mm(3.94 inch) or more from each other.
Not doing so could result in noise that may cause malfunction.

[Installation Precautions]

CAUTION

- Use the programmable controller in an environment that meets the general specifications contained in the CPU User's Manual.
Using this programmable controller in an environment outside the range of the general specifications may cause electric shock, fire, malfunction, and damage to or deterioration of the product.
- While pressing the installation lever located at the bottom of module, insert the module fixing tab into the fixing hole in the base unit until it stops. Then, securely mount the module with the fixing hole as a supporting point.
Improper installation may result in malfunction, breakdown or the module coming loose and dropping. Securely fix the module with screws if it is subject to vibration during use.
- Tighten the screws within the range of specified torque.
If the screws are loose, it may cause the module to fallout, short circuits, or malfunction.
If the screws are tightened too much, it may cause damage to the screw and/or the module, resulting in fallout, short circuits or malfunction.
- Be sure to shut off all phases of the external power supply used by the system before mounting or removing the module.
Not doing so may cause electric shock or damage to the module.
In the system where a CPU module supporting the online module change is used and on the MELSECNET/H remote I/O stations, modules can be replaced online (during energizing).
However, there are some restrictions on replaceable modules and the replacement procedures are predetermined for each module.
For details, refer to the chapter of the online module change in this manual.
- Do not directly touch the conductive area or electronic components of the module.
Doing so may cause malfunction or failure in the module.

[Wiring Precautions]

CAUTION

- Be careful not to let foreign matters such as sawdust or wire chips get inside the module.
They may cause fires, failure or malfunction.
- The top surface of the module is covered with protective film to prevent foreign objects such as cable offcuts from entering the module when wiring.
Do not remove this film until the wiring is complete.
Before operating the system, be sure to remove the film to provide adequate heat ventilation.
- Be sure to fix communication cables or power supply cables leading from the module by placing them in the duct or clamping them.
Cables not placed in the duct or without clamping may hang or shift, allowing them to be accidentally pulled, which may cause a module malfunction and cable damage.
- Do not grab on the cable when removing the communication or power cable connected to the module.
When disconnecting a cable without a connector, first loosen the screws on the part that is connected to the module.
Pulling the cable when it is still connected to the module may cause damage to the module or cable, or misoperation due to cable contact failure.
- Always ground the shielded cable for the programmable controller.
There is a risk of electric shock or malfunction.
- Use applicable solderless terminals and tighten them with the specified torque. If any solderless spade terminal is used, it may be disconnected when the terminal screw comes loose, resulting in failure.
- When wiring, be sure to verify the rated voltage of the product as well as the terminal layout. Fire or failure may result if incorrect voltage is input or incorrect wiring is performed.

[Startup/Maintenance Precautions]

CAUTION

- Do not disassemble or modify the module.
Doing so could cause failure, malfunction, injury or fire.
- Be sure to shut off all phases of the external power supply used by the system before mounting or removing the module.
Not doing so may cause failure or malfunction of the module.
In the system where a CPU module supporting the online module change is used and on the MELSECNET/H remote I/O stations, modules can be replaced online (during energizing).
However, there are some restrictions on replaceable modules and the replacement procedures are predetermined for each module.
For details, refer to the chapter of the online module change in this manual.
- Do not install/remove the module to/from the base unit, or the terminal block to/from the module more than 50 times after the first use of the product. (IEC 61131-2 compliant)
Failure to do so may cause malfunction.
- Do not touch the connector while the power is on.
Doing so may cause malfunction.
- Always shut off all phases of the external supply power used by the system before cleaning or retightening screws/module fixing screws.
Not doing so may cause failure or malfunction of the module.
If the screws are loose, it may cause the module to fallout, short circuits, or malfunction.
If the screws are tightened too much, it may cause damages to the screws and/or the module, resulting in the module falling out, short circuits or malfunction.
- Always make sure to touch the grounded metal to discharge the electricity charged in the body, etc., before touching the module.
Failure to do so may cause a failure or malfunctions of the module.

[Disposal Precautions]

CAUTION

- When disposing of the product, handle it as industrial waste.

• CONDITIONS OF USE FOR THE PRODUCT •

- (1) Mitsubishi programmable controller ("the PRODUCT") shall be used in conditions;
 - i) where any problem, fault or failure occurring in the PRODUCT, if any, shall not lead to any major or serious accident; and
 - ii) where the backup and fail-safe function are systematically or automatically provided outside of the PRODUCT for the case of any problem, fault or failure occurring in the PRODUCT.
- (2) The PRODUCT has been designed and manufactured for the purpose of being used in general industries.

MITSUBISHI SHALL HAVE NO RESPONSIBILITY OR LIABILITY (INCLUDING, BUT NOT LIMITED TO ANY AND ALL RESPONSIBILITY OR LIABILITY BASED ON CONTRACT, WARRANTY, TORT, PRODUCT LIABILITY) FOR ANY INJURY OR DEATH TO PERSONS OR LOSS OR DAMAGE TO PROPERTY CAUSED BY the PRODUCT THAT ARE OPERATED OR USED IN APPLICATION NOT INTENDED OR EXCLUDED BY INSTRUCTIONS, PRECAUTIONS, OR WARNING CONTAINED IN MITSUBISHI'S USER, INSTRUCTION AND/OR SAFETY MANUALS, TECHNICAL BULLETINS AND GUIDELINES FOR the PRODUCT.

("Prohibited Application")

Prohibited Applications include, but not limited to, the use of the PRODUCT in;

- Nuclear Power Plants and any other power plants operated by Power companies, and/or any other cases in which the public could be affected if any problem or fault occurs in the PRODUCT.
- Railway companies or Public service purposes, and/or any other cases in which establishment of a special quality assurance system is required by the Purchaser or End User.
- Aircraft or Aerospace, Medical applications, Train equipment, transport equipment such as Elevator and Escalator, Incineration and Fuel devices, Vehicles, Manned transportation, Equipment for Recreation and Amusement, and Safety devices, handling of Nuclear or Hazardous Materials or Chemicals, Mining and Drilling, and/or other applications where there is a significant risk of injury to the public or property.

Notwithstanding the above, restrictions Mitsubishi may in its sole discretion, authorize use of the PRODUCT in one or more of the Prohibited Applications, provided that the usage of the PRODUCT is limited only for the specific applications agreed to by Mitsubishi and provided further that no special quality assurance or fail-safe, redundant or other safety features which exceed the general specifications of the PRODUCTS are required. For details, please contact the Mitsubishi representative in your region.

REVISIONS

* The manual number is given on the bottom left of the back cover.

Print Date	* Manual Number	Revision
Oct., 2000	SH (NA)-080121-A	First edition
Jun., 2001	SH (NA)-080121-B	Standardize the name from software package (GPP function) to Product name (GX Developer). Standardize the name from utility package (QTCU) to Product name (GX Configurator-TC). <div style="border: 1px solid black; padding: 2px; display: inline-block;">Addition</div> Section 1.4, Section 2.1, 2.2 <div style="border: 1px solid black; padding: 2px; display: inline-block;">Correction</div> CONFORMATION TO THE EMC DIRECTIVE AND LOW VOLTAGE INSTRUCTION, ABOUT THE GENERIC TERMS AND ABBREVIATIONS, PRODUCT STRUCTURE, Section 3.5.47, Section 5.2, 5.2.1, 5.2.2, 5.3.3, 5.6
Feb., 2002	SH (NA)-080121-C	Add the contents of the function version C <div style="border: 1px solid black; padding: 2px; display: inline-block;">Addition</div> Chapter 7 <div style="border: 1px solid black; padding: 2px; display: inline-block;">Renumbering</div> Chapter 7 → Chapter 8 <div style="border: 1px solid black; padding: 2px; display: inline-block;">Correction</div> SAFETY PRECAUTIONS, ABOUT THE GENERIC TERMS AND ABBREVIATIONS, Section 2.1, 2.2, Section 3.1.1, 3.2, 3.2.1, 3.2.10, 3.2.11, 3.5.1, 3.5.11, 3.5.20, 3.5.32, 3.5.42, Section 4.3, Section 5.2.1, 5.2.2, Section 6.2.2, 6.3, Section 8.1
Aug., 2002	SH (NA)-080121-D	<div style="border: 1px solid black; padding: 2px; display: inline-block;">Correction</div> Section 2.1, Section 3.1, 3.2.1, 3.2.7, 3.5.1, 3.5.12, 3.5.15, 3.5.20, 3.5.26, 3.5.34, 3.5.35, 3.5.44, 3.5.45, 3.5.49, 3.5.51, 3.5.52, Section 6.3, Section 8.10
Feb., 2003	SH (NA)-080121-E	<div style="border: 1px solid black; padding: 2px; display: inline-block;">Correction</div> SAFETY PRECAUTIONS, INTRODUCTION, CONTENTS, Section 2.1, Section 3.1.1, Section 3.5.38, Section 5.2.2, Section 5.3.3, Section 5.4 to Section 5.6
May, 2003	SH (NA)-080121-F	<div style="border: 1px solid black; padding: 2px; display: inline-block;">Correction</div> Section 2.1, Section 3.5.15, Section 3.5.36, Section 6.3
May, 2004	SH (NA)-080121-G	Addition of program example for use on the remote I/O network <div style="border: 1px solid black; padding: 2px; display: inline-block;">Correction</div> Section 2.1, 2.2, Section 3.5.4, Chapter 6, Section 7.1, 7.3.1, 7.3.2
Oct., 2004	SH (NA)-080121-H	<div style="border: 1px solid black; padding: 2px; display: inline-block;">Correction</div> SAFETY PRECAUTIONS, Section 2.1, Section 3.1.1, 3.2.1, Section 4.1, Section 6.3, 6.3.1, Section 8.1

* The manual number is given on the bottom left of the back cover.

Print Date	* Manual Number	Revision
Jul., 2005	SH (NA)-080121-I	<p>Correction</p> <p>SAFETY PRECAUTIONS, CONFORMATION TO THE EMC DIRECTIVE AND LOW VOLTAGE INSTRUCTION, Section 1.3.4, Section 2.1, 2.2, Section 3.1.1, 3.2.11, 3.4.3, 3.5.2, 3.5.8, Section 4.5, Section 5.1, 5.2.1, 5.3.2, 5.3.3, 5.4, 5.5, 5.6, Section 6.2, 6.2.1, 6.3, 6.3.1, Section 7.2, 7.3.1, 7.3.2, Section 8.10</p>
Mar., 2006	SH(NA)-080121-J	<p>Correction</p> <p>SAFETY PRECAUTIONS, CONFORMATION TO THE EMC DIRECTIVE AND LOW VOLTAGE INSTRUCTION, Section 3.5.26</p>
Sep., 2007	SH(NA)-080121-K	<p>Correction</p> <p>SAFETY PRECAUTIONS, CONTENTS, CONFORMATION TO THE EMC DIRECTIVE AND LOW VOLTAGE INSTRUCTION, Chapter 1, Section 1.1, 1.4, Section 2.1, 2.2, Chapter 3, Section 3.1.1, 3.2, 3.2.1, 3.2.6, 3.2.7, 3.2.10, 3.2.11, 3.2.12, 3.4.1, 3.4.2, 3.4.3, 3.5.1, 3.5.2, 3.5.3, 3.5.16, 3.5.24, 3.5.25, 3.5.30, 3.5.38, 3.5.41, 3.5.42, 3.5.43, 3.5.44, 3.5.48, Section 4.3, 4.4.1, 4.4.2, 4.4.3, Section 5.1, 5.3.1, 5.3.2, 5.3.3, 5.4, 5.5, 5.6, Section 6.2.1, 6.3, Chapter 7, Section 7.1, 7.2, 7.3.1, 7.3.2, 7.4, Section 8.2, 8.3, 8.6, INDEX</p>
Jan., 2008	SH(NA)-080121-L	<p>Correction</p> <p>SAFETY PRECAUTIONS, CONTENTS, ABOUT THE GENERIC TERMS AND ABBREVIATIONS, Section 2.2 to 2.4, 3.2.1, 3.2.7, 3.5.11, 3.5.34, 5.2.2, 8.9 to 8.11</p>
May, 2008	SH(NA)-080121-M	<p>Correction</p> <p>SAFETY PRECAUTIONS, CONFORMANCE WITH THE EMC AND LOW VOLTAGE DIRECTIVES, ABOUT THE GENERIC TERMS AND ABBREVIATIONS, Section 2.1, 2.3, 4.1, 5.2.1, 5.3.1, 5.3.3, 7.1</p>
Feb., 2011	SH(NA)-080121-N	<p>Addition</p> <p>CONDITIONS OF USE FOR THE PRODUCT</p> <p>Correction</p> <p>SAFETY PRECAUTIONS, ABOUT THE GENERIC TERMS AND ABBREVIATIONS, Section 1.1, Section 2.1 to 2.3, Section 3.1.1, 3.2.1, 3.2.2, 3.2.4 to 3.2.7, 3.2.11, 3.3, 3.4.2, 3.4.3, 3.5.1, 3.5.3, 3.5.5 to 3.5.8, 3.5.11, 3.5.12 to 3.5.20, 3.5.23 to 3.5.27, 3.5.29, 3.5.31 to 3.5.34, 3.5.37, 3.5.41, 3.5.43, 3.5.45 to 3.5.47, 3.5.49, Section 4.3, 4.4.1 to 4.4.3, Section 5.1, 5.4, 5.6, 5.2.1, Section 6.2.1, 6.3.1, 6.3.2, Section 7.1, 7.3.1, 7.3.2, 8.1, Section 8.2, 8.5, 8.11, 8.12, Appendix 1</p>
Jul., 2015	SH(NA)-080121-O	<p>Addition</p> <p>Section 2.4</p>

Japanese Manual Version SH-080108-R

This manual confers no industrial property rights or any rights of any other kind, nor does it confer any patent licenses. Mitsubishi Electric Corporation cannot be held responsible for any problems involving industrial property rights which may occur as a result of using the contents noted in this manual.

© 2000 MITSUBISHI ELECTRIC CORPORATION

INTRODUCTION

Thank you for the purchasing the MELSEC-Q series programmable controller.
Before using the equipment, please read this manual carefully to develop full familiarity with the functions and performance of the Q series programmable controller you have purchased, so as to ensure correct use.

CONTENTS

SAFETY PRECAUTIONS	A- 1
CONDITIONS OF USE FOR THE PRODUCT	A- 5
REVISIONS	A- 6
INTRODUCTION.....	A- 8
CONTENTS.....	A- 8
CONFORMANCE WITH THE EMC AND LOW VOLTAGE DIRECTIVES.....	A-12
ABOUT THE GENERIC TERMS AND ABBREVIATIONS.....	A-13
PRODUCT STRUCTURE.....	A-13

1 GENERAL DESCRIPTION	1- 1 to 1-12
------------------------------	---------------------

1.1 Features	1- 3
1.2 The PID Control System	1- 5
1.3 About the PID Operation.....	1- 6
1.3.1 Operation method and formula	1- 6
1.3.2 The Q64TC actions	1- 7
1.3.3 Proportional action (P-action)	1- 8
1.3.4 Integral action (I-action)	1- 9
1.3.5 Derivative action (D-action).....	1-10
1.3.6 PID action	1-11
1.4 Functions Added to Function Version B and Later	1-12

2 SYSTEM CONFIGURATION	2- 1 to 2-11
-------------------------------	---------------------

2.1 Applicable Systems.....	2- 1
2.2 For Use the Q64TC with Redundant CPUs	2- 6
2.3 Checking Function Version/Serial No./Product Information/Software Version	2- 7
2.4 Precautions for System Configuration.....	2-10

3 SPECIFICATIONS	3- 1 to 3-60
-------------------------	---------------------

3.1 Performance Specifications	3- 1
3.1.1 Performance specifications of the Q64TC	3- 1
3.1.2 Usable temperature sensor types, measurement temperature ranges and data resolutions	3- 3
3.2 Function Summary.....	3- 4
3.2.1 Auto tuning function	3- 5
3.2.2 Reverse/Forward action select function	3-10
3.2.3 RFB limiter function	3-10
3.2.4 Sensor compensation function	3-10
3.2.5 Unused channel setting	3-11
3.2.6 Forced PID control stop	3-11
3.2.7 Heater disconnection detection function (available for the Q64TCTTBW, Q64TCRTBW only) ...	3-12

3.2.8 Output off-time current error detection function (available for the Q64TCTTBW and Q64TCRTBW only)	3-15
3.2.9 Loop disconnection detection function	3-15
3.2.10 Data storage on E ² PROM.....	3-16
3.2.11 Alerts function.....	3-18
3.2.12 Control output setting at CPU stop error occurrence.....	3-22
3.2.13 The settings and control status of the output signal and buffer memory controlling the Q64TC control status.....	3-23
3.3 Sampling Period and Control Output Period.....	3-24
3.4 I/O Signals Transferred to/from the programmable controller CPU.....	3-25
3.4.1 I/O signal list	3-25
3.4.2 Input signal functions	3-26
3.4.3 Output signal functions.....	3-29
3.5 Buffer Memory.....	3-31
3.5.1 Buffer memory list	3-31
3.5.2 Write data error code (buffer memory address: 0H).....	3-35
3.5.3 Decimal point position (buffer memory address: 1H to 4H)	3-36
3.5.4 Alert definition (buffer memory address: 5H to 8H)	3-37
3.5.5 Temperature process value (PV) (buffer memory address: 9H to CH)	3-37
3.5.6 Manipulated value (MV) (buffer memory address: DH to 10H).....	3-38
3.5.7 Temperature rise judgment flag (buffer memory address: 11H to 14H).....	3-38
3.5.8 Transistor output flag (buffer memory address: 15H to 18H).....	3-38
3.5.9 Q64TCTT(BW) Cold junction temperature process value (buffer memory address: 1DH).....	3-39
3.5.10 MAN mode shift completion flag (buffer memory address: 1EH).....	3-39
3.5.11 E ² PROM's PID constant read/write completion flag (buffer memory address: 1FH)	3-40
3.5.12 Input range (buffer memory address: 20H, 40H, 60H, 80H).....	3-42
3.5.13 Stop mode setting (buffer memory address: 21H, 41H, 61H, 81H).....	3-44
3.5.14 Set value (SV) setting (buffer memory address: 22H, 42H, 62H, 82H).....	3-45
3.5.15 PID constant setting (buffer memory address: 23H to 25H, 43H to 45H, 63H to 65H, 83H to 85H)	3-45
3.5.16 Alert set value 1 to 4 (buffer memory address: 26H to 29H, 46H to 49H, 66H to 69H, 86H to 89H)	3-47
3.5.17 Upper/lower output limiter (buffer memory address: 2AH, 2BH, 4AH, 4BH, 6AH, 6BH, 8AH, 8BH)	3-47
3.5.18 Output variation limiter (buffer memory address: 2CH, 4CH, 6CH, 8CH).....	3-48
3.5.19 Sensor compensation value setting (buffer memory address: 2DH, 4DH, 6DH, 8DH)	3-48
3.5.20 Adjustment sensitivity (dead band) setting (buffer memory address: 2EH, 4EH, 6EH, 8EH)	3-48
3.5.21 Control output period setting (buffer memory address: 2FH, 4FH, 6FH, 8FH)	3-49
3.5.22 Primary delay digital filter setting (buffer memory address: 30H, 50H, 70H, 90H)	3-49
3.5.23 Control response parameter (buffer memory address: 31H, 51H, 71H, 91H)	3-50
3.5.24 AUTO/MAN mode switching (buffer memory address: 32H, 52H, 72H, 92H)	3-50
3.5.25 MAN output setting (buffer memory address: 33H, 53H, 73H, 93H).....	3-51
3.5.26 Setting change rate limiter (buffer memory address: 34H, 54H, 74H, 94H)	3-51
3.5.27 AT bias (buffer memory address: 35H, 55H, 75H, 95H).....	3-51
3.5.28 Forward/reverse action setting (buffer memory address: 36H, 56H, 76H, 96H).....	3-53
3.5.29 Upper/lower setting limiter (buffer memory address: 37H, 38H, 57H, 58H, 77H, 78H, 97H, 98H).....	3-53
3.5.30 Heater disconnection alert setting (buffer memory address: 3AH, 5AH, 7AH, 9AH).....	3-53

3.5.31 Loop disconnection detection judgment time (buffer memory address: 3BH, 5BH, 7BH, 9BH)	3-54
3.5.32 Loop disconnection detection dead band (buffer memory address: 3CH, 5CH, 7CH, 9CH)	3-54
3.5.33 Unused channel setting (buffer memory address: 3DH, 5DH, 7DH, 9DH)	3-55
3.5.34 E ² PROM's PID constant read command (buffer memory address: 3EH, 5EH, 7EH, 9EH)	3-55
3.5.35 Automatic backup setting after auto tuning of PID constants (buffer memory address: 3FH, 5FH, 7FH, 9FH)	3-56
3.5.36 Alert dead band setting (buffer memory address: A4H)	3-56
3.5.37 Alert delay count (buffer memory address: A5H)	3-56
3.5.38 Heater disconnection/output off-time current error detection delay count (buffer memory address: A6H)	3-56
3.5.39 Temperature rise completion range setting (buffer memory address: A7H)	3-57
3.5.40 Temperature rise completion soak time setting (buffer memory address: A8H)	3-57
3.5.41 PID continuation flag (buffer memory address: A9H)	3-57
3.5.42 Heater disconnection compensation function selection (buffer memory address: AAH)	3-57
3.5.43 Transistor output monitor ON delay time setting (buffer memory address: AFH)	3-57
3.5.44 CT monitor method switching (buffer memory address: B0H)	3-58
3.5.45 Manipulated value (0 to 4000/0 to 12000/0 to 16000) (buffer memory address: B1H to B4H)	3-58
3.5.46 Manipulated value resolution switching (buffer memory address: B5H)	3-58
3.5.47 Auto tuning mode selection (buffer memory address: B8H to BBH)	3-58
3.5.48 Alert 1 to 4 mode setting (buffer memory address: C0H to C3H, D0H to D3H, E0H to E3H, F0H to F3H)	3-59
3.5.49 Heater current process value (buffer memory address: 100H to 107H)	3-59
3.5.50 CT input channel assignment setting (buffer memory address: 108H to 10FH)	3-60
3.5.51 CT selection (buffer memory address: 110H to 117H)	3-60
3.5.52 Reference heater current value (buffer memory address: 118H to 11FH)	3-60

4 SETUP AND PROCEDURE BEFORE STARTING THE OPERATION	4- 1 to 4-13
--	---------------------

4.1 Handling Precautions	4- 1
4.2 Procedure Before Starting the Operation	4- 2
4.3 Parts Identification	4- 3
4.4 Wiring	4- 6
4.4.1 Wiring precautions	4- 6
4.4.2 External wiring	4- 7
4.4.3 Heater disconnection detection wiring and setting example for use of three-phase heater	4-11
4.5 Switch Settings for the Intelligent Function Module	4-12

5 UTILITY PACKAGE (GX Configurator-TC)	5- 1 to 5-21
---	---------------------

5.1 Functions of the Utility Package	5- 1
5.2 Installing and Uninstalling the Utility Package	5- 4
5.2.1 Handling precautions	5- 4
5.2.2 Operating environment	5- 6
5.3 Utility Package Operation	5- 8
5.3.1 Common utility package operations	5- 8
5.3.2 Operation overview	5-10
5.3.3 Starting the Intelligent function module utility	5-12

5.4 Initial Settings	5-14
5.5 Auto Refresh Setting	5-17
5.6 Monitoring /Test.....	5-19

6 PROGRAMMING	6- 1 to 6-13
----------------------	---------------------

6.1 Programming Procedure.....	6- 1
6.2 For Use in Nomal System Configuration	6- 2
6.2.1 Program example using the utility package	6- 3
6.2.2 Program example without using the utility package.....	6- 5
6.3 For Use in Remote I/O Network	6- 7
6.3.1 Program example using the utility package	6- 8
6.3.2 Program example without using the utility package.....	6-11

7 ONLINE MODULE CHANGE	7- 1 to 7-14
-------------------------------	---------------------

7.1 Online Module Change Conditions.....	7- 2
7.2 Online Module Change Operations	7- 3
7.3 Online Module Change Procedure.....	7- 4
7.3.1 GX Configurator-TC was used for initial setting.....	7- 4
7.3.2 Sequence program was used for initial setting	7- 9
7.4 Precautions for Online Module Change	7-14

8 TROUBLESHOOTING	8- 1 to 8- 9
--------------------------	---------------------

8.1 Error Code List	8- 1
8.2 Processing Performed by the Q64TC at Error Occurrence.....	8- 2
8.3 If the RUN LED Has Flickered or Turned Off.....	8- 3
8.4 If the ERR. LED Has Turned On or Flickered.....	8- 3
8.5 If the ALM LED Has Turned On or Flickered	8- 3
8.6 If the Module Ready Flag (Xn0) Does Not Turn On	8- 4
8.7 If the Write Error Flag (Xn2) Has Turned On	8- 4
8.8 If the Hardware Error Flag (Xn3) Has Turned On.....	8- 4
8.9 If the Auto Tuning Does Not Start (If the Auto Tuning Status (Xn4 to Xn7) Does Not Turn On).....	8- 4
8.10 If the Auto Tuning Is Not Completed (If the Auto Tuning Status (Xn4 to Xn7) Remains On and Does Not Turn Off).....	8- 5
8.11 If the Alert Occurrence Flag (XnC to XnF) Has Turned On.....	8- 5
8.12 Checking the Q64TC Status by System Monitoring of GX Developer.....	8- 6

APPENDIX	Appendix- 1 to Appendix- 3
-----------------	-----------------------------------

Appendix 1 External Dimensions.....	Appendix- 1
-------------------------------------	-------------

INDEX	Index- 1 to Index- 3
--------------	-----------------------------

CONFORMANCE WITH THE EMC AND LOW VOLTAGE DIRECTIVES

(1) For programmable controller system

To configure a system meeting the requirements of the EMC and Low Voltage Directives when incorporating the Mitsubishi programmable controller (EMC and Low Voltage Directives compliant) into other machinery or equipment, refer to Chapter 9 "EMC AND LOW VOLTAGE DIRECTIVES" of the QCPU User's Manual (Hardware Design, Maintenance and Inspection).

The CE mark, indicating compliance with the EMC and Low Voltage Directives, is printed on the rating plate of the programmable controller.

(2) For the product

The following wiring is required for the compliance of this product with the EMC and Low Voltage Directives.

- (a) Use shielded cables for all external wiring and ground them to the control panel with the AD75CK cable clamp.

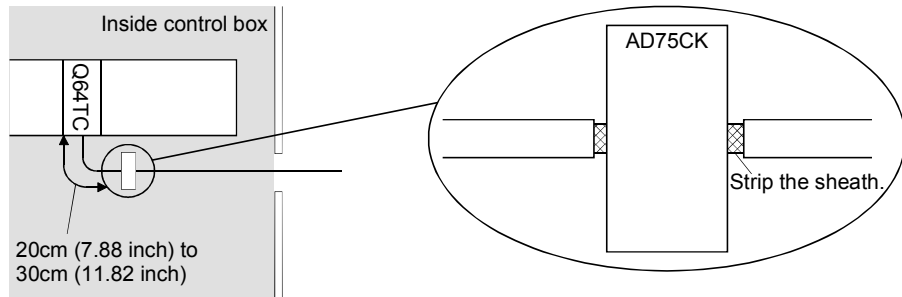

- (b) Four cables can be grounded together with the AD75CK cable clamp when the diameter of each cable is approximately 7mm (0.28 inch).

- (c) The following number of AD75CKs will be needed.
(Assuming that 7mm-diameter cables are used for all wiring)

Number of AD75CKs needed	Number of channels used				
	1	2	3	4	
Number of CT channels used	0	1	1	2	2
	1	1	2	2	3
	2	1	2	2	3
	3	2	2	3	3
	4	2	2	3	3
	5	2	3	3	4
	6	2	3	3	4
	7	3	3	4	4
8	3	3	4	4	

ABOUT THE GENERIC TERMS AND ABBREVIATIONS

Unless otherwise specified, this manual uses the following generic terms and abbreviations to describe the Temperature control module.

Generic term/abbreviation	Description
Personal computer	DOS/V-compatible personal computer of IBM PC/AT® or its compatible.
GX Developer	Product name of MELSEC programmable controller software package
GX Works2	
QCPU (Q mode)	Generic term of the Q00JCPU, Q00CPU, Q01CPU, Q02CPU, Q02HCPU, Q06HCPU, Q12HCPU, Q25HCPU, Q02PHCPU, Q06PHCPU, Q12PHCPU, Q25PHCPU, Q12PRHCPU, Q25PRHCPU, Q00UJCPU, Q00UCPU, Q01UCPU, Q02UCPU, Q03UDCPU, Q04UDHCPU, Q06UDHCPU, Q10UDHCPU, Q13UDHCPU, Q20UDHCPU, Q26UDHCPU, Q03UDECPU, Q04UDEHCPU, Q06UDEHCPU, Q10UDEHCPU, Q13UDEHCPU, Q20UDEHCPU, Q26UDEHCPU, Q50UDEHCPU, and Q100UDEHCPU.
Process CPU	Generic term of the Q02PHCPU, Q06PHCPU, Q12PHCPU and Q25PHCPU.
Redundant CPU	Generic term for the Q12PRHCPU and Q25PRHCPU.
GX Configurator-TC	Generic term of temperature control module setting/monitoring tool GX Configurator-TC(SW0D5C-QTCU-E).
Q64TCTT	Abbreviation of Type Q64TCTT temperature control module.
Q64TCTTBW	Abbreviation of Type Q64TCTTBW temperature control module with disconnection detection function.
Q64TCRT	Abbreviation of Type Q64TCRT temperature control module.
Q64TCRTBW	Abbreviation of Type Q64TCRTBW temperature control module with disconnection detection function.
Q64TC	Generic term of Type Q64TCTT, Q64TCTTBW, Q64TCRT and Q64TCRTBW.
Windows Vista®	Generic term for the following: Microsoft® Windows Vista® Home Basic Operating System, Microsoft® Windows Vista® Home Premium Operating System, Microsoft® Windows Vista® Business Operating System, Microsoft® Windows Vista® Ultimate Operating System, Microsoft® Windows Vista® Enterprise Operating System
Windows® XP	Generic term for the following: Microsoft® Windows® XP Professional Operating System, Microsoft® Windows® XP Home Edition Operating System

PRODUCT STRUCTURE

The product structure of the product is given in the table below.

Model code	Product name	Quantity
Q64TCTT	Type Q64TCTT temperature control module	1
Q64TCTTBW	Type Q64TCTTBW temperature control module with disconnection detection function	1
Q64TCRT	Type Q64TCRT temperature control module	1
Q64TCRTBW	Type Q64TCRTBW temperature control module with disconnection detection function	1
SW0D5C-QTCU-E	GX Configurator-TC Version 1 (1-license product) (CD-ROM)	1
SW0D5C-QTCU-EA	GX Configurator-TC Version 1 (Multiple-license product) (CD-ROM)	1

1 GENERAL DESCRIPTION

1

This manual deals with the specifications, handling and instructions wiring and programming methods of the following temperature control modules used with the MELSEC-Q series programmable controller CPU module (hereafter abbreviated to the programmable controller CPU).

- Type Q64TCTT temperature control module
- Type Q64TCRT temperature control module
- Type Q64TCTTBW temperature control module with disconnection detection function
- Type Q64TCRTBW temperature control module with disconnection detection function

(1) What are the Q64TCTT and Q64TCRT?

- (a) The Q64TCTT and Q64TCRT are modules designed to convert input values from external temperature sensors into 16-bit signed BIN (binary) data, perform PID operations to attain target temperatures, and provide transistor outputs for temperature control.
- (b) The Q64TCTT and Q64TCRT have an auto tuning function which automatically sets the proportional band (P), integral time (I) and derivative time (D) for PID operations.
- (c) The Q64TCTT accepts K, J, T, B, S, E, R, N, U, L, PL II and W5Re/W26Re type thermocouples. The Q64TCRT accepts Pt100 and JPt100 type platinum temperature-measuring resistors.

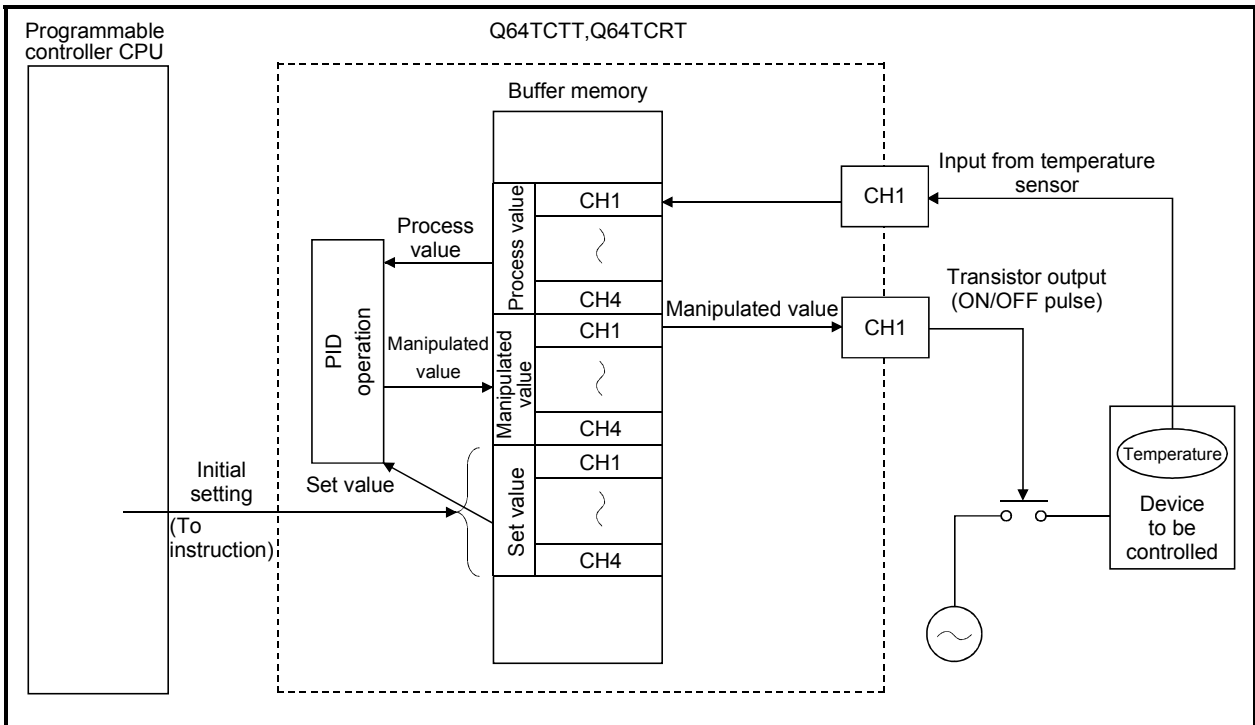

Fig. 1.1 Q64TCTT or Q64TCRT Processing Outline

REMARK

- 1) Refer to Section 3.2.1 for the auto tuning function.
- 2) Refer to Section 3.1.2 for the measured temperature ranges of the temperature sensors that can be connected to the Q64TC.

(2) What are the Q64TCTTBW and Q64TCRTBW?

The Q64TCTTBW and Q64TCRTBW are the Q64TCTT and Q64TCRT-based modules which have the additional function to detect a heater wire disconnection using inputs from external current sensors.

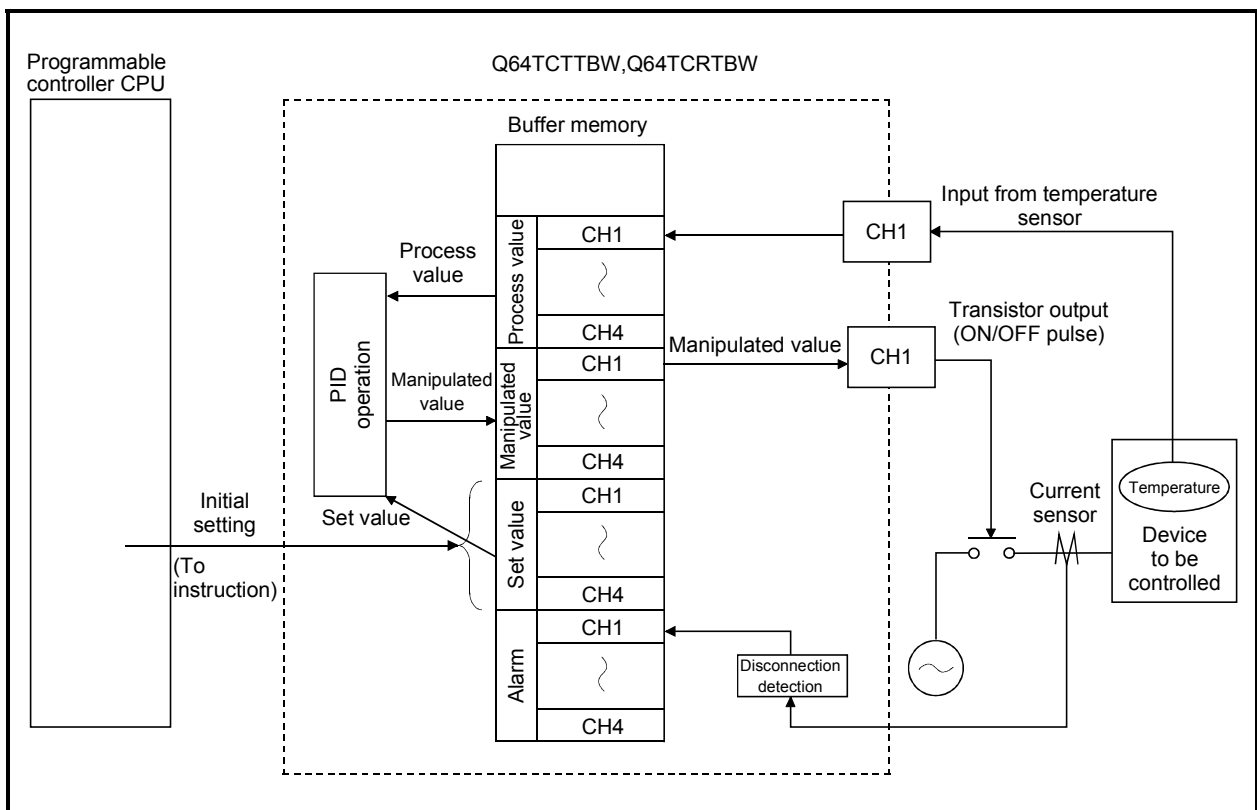

Fig. 1.2 Q64TCTTBW or Q64TCRTBW Processing Outline

REMARK

- 1) Refer to Section 3.2.7 for the disconnection detection function of the Q64TCTTBW and Q64TCRTBW.

1.1 Features

The Q64TC has the following features.

(1) Optimum temperature adjustment control (PID control)

(a) The Q64TC exercises temperature adjustment control automatically by merely setting the PID constants (proportional band (P), integral time (I), derivative time (D)) and temperature set value (set value: SV) necessary for PID operations.

Therefore, no special instructions are needed to perform PID control.

(b) Using the auto tuning function enables the PID constants to be set automatically by the Q64TC.

Hence, you can use the equipment without being conscious of cumbersome PID operation expressions to find the PID constants.

(2) 4 loops on 1 module

The module provides a maximum of four loops at the same time for temperature adjustment control.

(3) RFB limiter function

The RFB (Reset FeedBack) limiter suppresses overshooting which is liable to occur at a startup or when a temperature set value (SV) is increased.

(4) Sensor compensation function

By setting a sensor compensation value, the sensor compensation function eliminates a difference between a temperature process value (PV) and an actual temperature, if any.

(5) Connection of thermocouples compatible with JIS, IEC, NBS, ASTM and DIN Standards

(a) The Q64TCTT(BW) accepts the following thermocouples compatible with the JIS, IEC, NBS, ASTM and DIN Standards.

- JIS Standards : R, K, J, S, B, E, T
- IEC Standards: R, K, J, S, B, E, T, N
- NBS Standards : PL II
- ASTM Standards: W5Re/W26Re
- DIN Standards : U, L

(b) The Q64TCTT(BW) allows you to set the temperature measurement ranges which meet the operating temperatures of the above thermocouples.

(6) Connection of Pt100 and JPt100 platinum temperature-measuring resistors

The Q64TCTT(BW) allows you to set the temperature measurement ranges which meet the operating temperatures of the Pt100 and JPt100.

(7) Choice of fine temperature measurement units and various control temperature ranges

The temperature measurement unit of each loop can be set to 1°C or 0.1°C in Centigrade or to 1°F or 0.1°F in Fahrenheit, enabling you to choose appropriate resolution for control. Also, the controllable temperature range can be selected from 0.0 to 400.0°C (when K type thermocouple is used), 0.0 to 3000.0°C (when R type thermocouple is used) and others, enabling you to make adequate setting for the object to be controlled.

(8) E²PROM for backing up set values

The set values in buffer memory can be stored into E2PROM for data backup. Using the test function of GX Developer to write data directly to the buffer memory, what is required in a sequence program is "LD**" + "OUT Yn1" at the minimum.

(9) Detection of disconnection

The Q64TCTTBW and Q64TCRTBW can detect the disconnection of a heater.

(10) Easy settings with GX Configurator-TC

Sequence programs can be reduced since the GX Configurator-TC (sold separately) allows the Q64TC settings on the screen.

Also, the GX Configurator-CT simplifies the confirmation of the module settings and operation status.

1.2 The PID Control System

(1) The PID control system

Figure 1.3 indicates the system configuration when performing PID control.

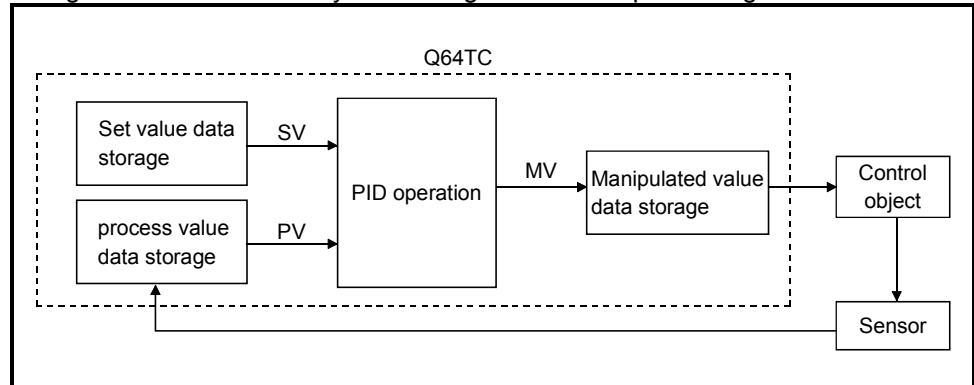

Fig. 1.3 The PID control system

(2) PID control procedure

The PID control is performed in the procedure shown in Figure 1.4 below:

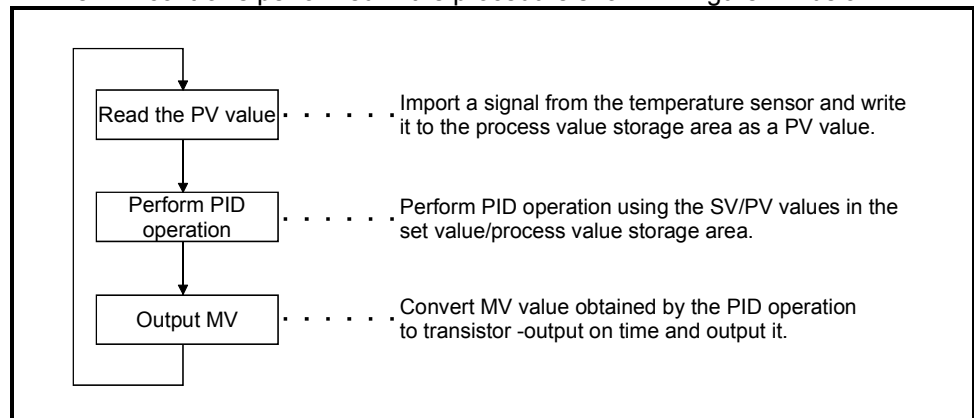

Fig. 1.4 PID control procedure

(3) PID control (simplified two-level response selection)

In general, when the P, I, and D constants to improve the "response to the setting" are set, the "response to the disturbance" degrades by the PID control. Conversely, when the P, I, and D constants to improve the "response to the disturbance" are set, the "response to the setting" degrades by the PID control. In the PID control (simplified two-level response selection) of this module, "fast", "normal", or "slow" can be selected for the "response to the setting" while the P, I, and D constants for better "response for the disturbance" are selected.

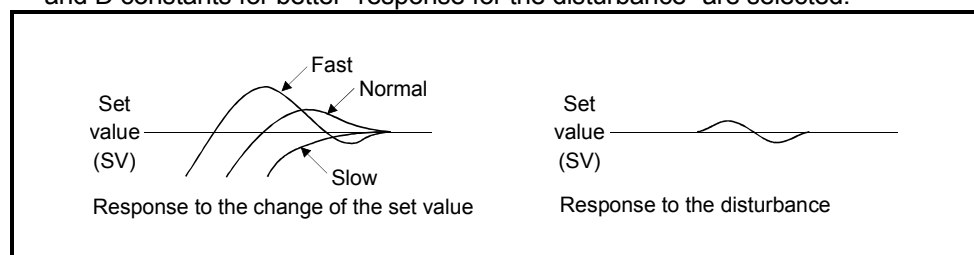

Fig. 1.5 simplified two-level response selection

1.3 About the PID Operation

The Q64TC can perform PID control in process-value incomplete differentiation.

1.3.1 Operation method and formula

The PID control in process-value incomplete differentiation is an operation method which puts the first-order delay filter as the input for derivative control action, and performs PID operation with the error deviation (E) after deleting the high-frequency noise component.

(1) The algorithm of the PID control in process-value incomplete differentiation is shown in Figure 1.6.

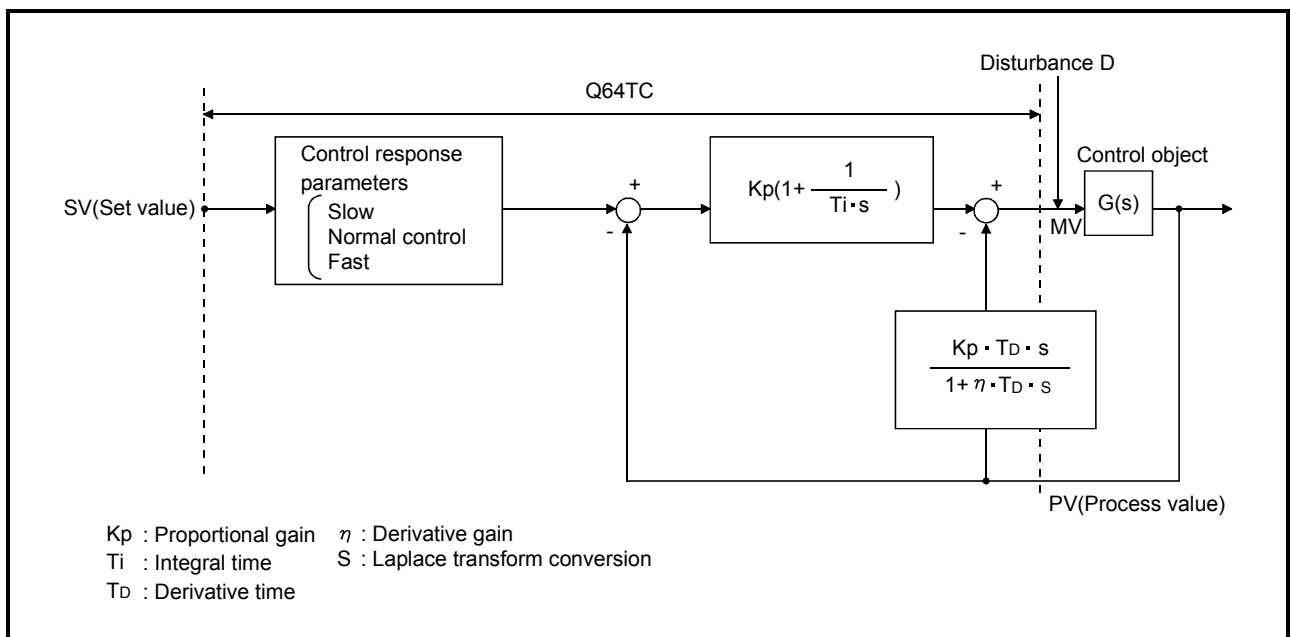

Fig. 1.6 Algorithm of PID control in process-value incomplete differentiation

(2) The formula used for the Q64TC is shown below:

$$MV_n = MV_{n-1} + \frac{T_D}{\tau + \eta \cdot T_D} \left\{ (PV_{n-1} - PV_n) - \frac{\tau}{T_D} \cdot MV_{n-1} \right\}$$

- τ : Sampling period
- MV : Incomplete derivative output
- PV : Process value
- T_D : Derivative time
- $\frac{1}{\eta}$: Derivative gain

1.3.2 The Q64TC actions

The Q64TC performs PID operations in reverse action and forward action.

(1) Reverse action

In a reverse action, the process value (PV) increases toward the set value (SV) as the manipulated value (MV) increases.

The reverse action is effective for heat control.

(2) Forward action

In a forward action, the process value (PV) decreases toward the set value (SV) as the manipulated value (MV) increases.

The forward action is effective for cooler control.

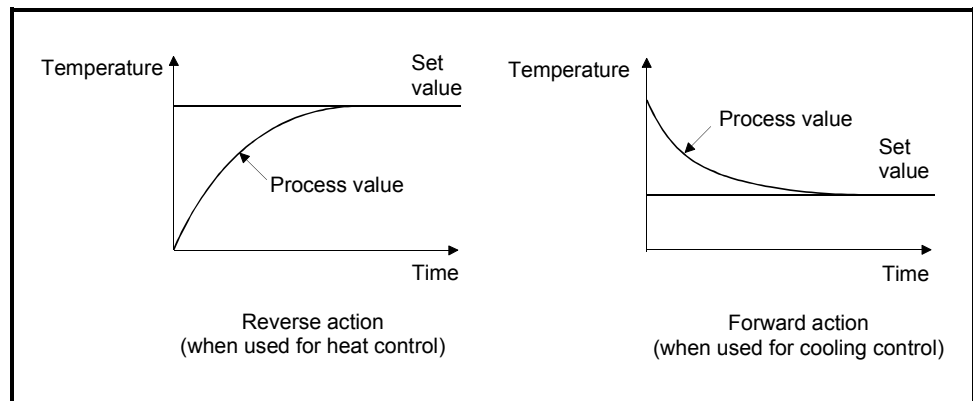

Fig. 1.7 Process control example in reverse action and forward action

1.3.3 Proportional action (P-action)

- (1) The proportional action is an action to obtain the manipulation value proportional to the deviation (difference between set value and process value).
- (2) With the proportional action, the relationship between the changes in the deviation (E) and manipulated value (MV) can be expressed in the following formula:
$$MV = K_P \cdot E$$
where K_P is a proportional constant and is called the proportional gain.
- (3) The proportional action for the step response when the error value is constant is shown in Figure 1.8.
- (4) The manipulation value changes between -5.0% and 105.0%. As the K_P increases, the manipulation value for the same error value becomes larger, and the corrective action becomes stronger.
- (5) The proportional action will generate an offset (remaining deflection).

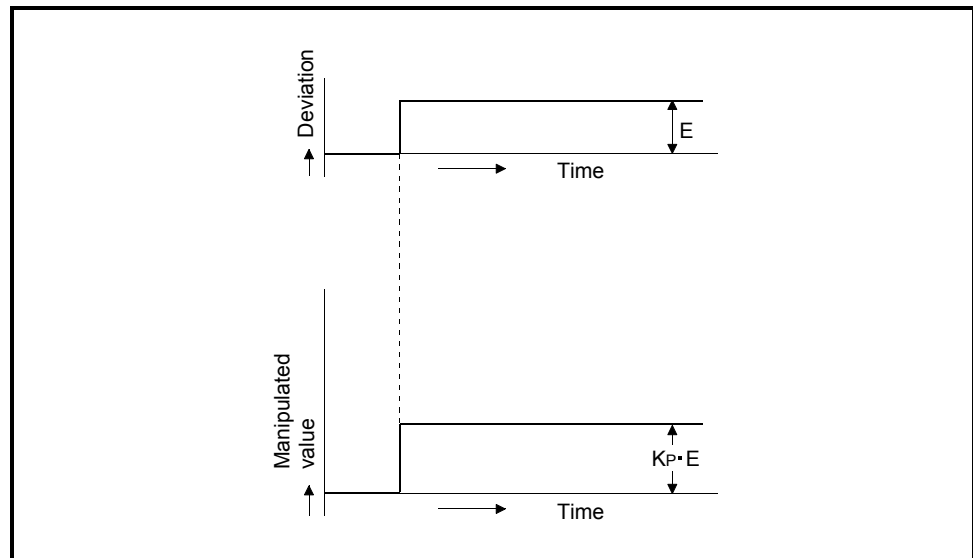

Fig. 1.8 Proportional action for step response

1.3.4 Integral action (I-action)

- (1) The integral action is an action which continuously changes the manipulation value to eliminate the deviation when there is a deviation.
The offset produced by the proportional action can be eliminated.
- (2) In the integral action, the time from the deviation occurrence until the manipulation value of the integral action becomes that of the proportional control action is called the integral time, and is indicated by T_i .
- (3) The integral action for the step response when the error value is constant is shown in Figure 1.9.
- (4) The integral action is used as a PI action in combination with the proportional action, or PID action in combination with the proportional and derivative actions.
The integral action cannot be used alone.

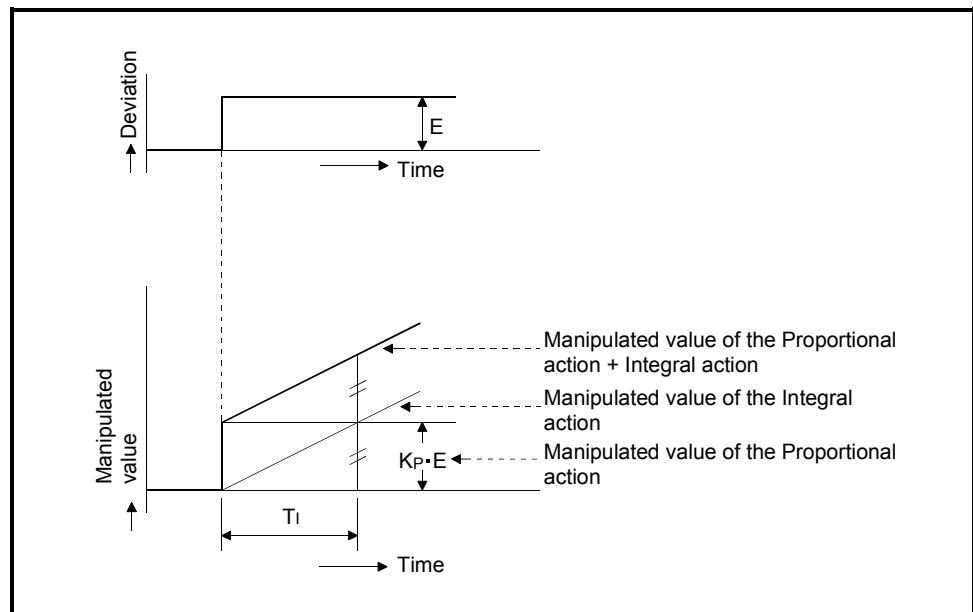

Fig. 1.9 Integral action for step response

1.3.5 Derivative action (D-action)

- (1) The derivative action adds the manipulation value proportional to the change speed to eliminate error when a deviation occurs.
The derivative control action can prevent the control target from changing significantly due to disturbance.
- (2) In the derivative action, the time from the deviation occurrence until the manipulation value of the derivative action becomes that of the proportional action is called the derivative time, and is indicated by T_D .
- (3) The derivative action for the step response when the deviation is constant is shown in Figure 1.10.
- (4) The derivative action is used as a PD action in combination with the proportional action, or PID action in combination with the proportional and integral actions.
The derivative action cannot be used alone.

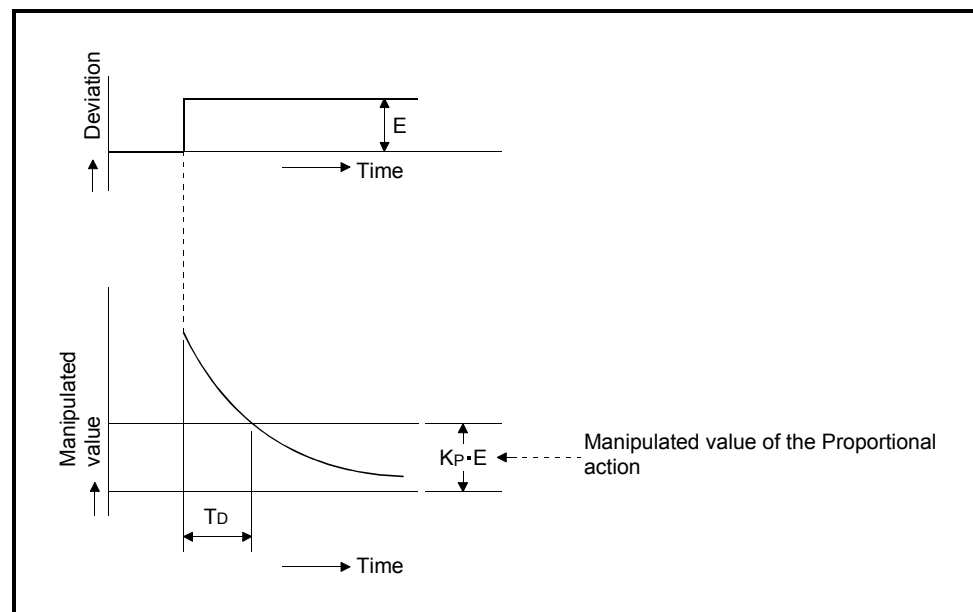

Fig. 1.10 Derivative action for step response

1.3.6 PID action

- (1) The PID action performs control using the manipulation value obtained by merging proportional action, integral action and derivative action.
- (2) The PID action for the step response when the deviation is constant is shown in Figure 1.11.

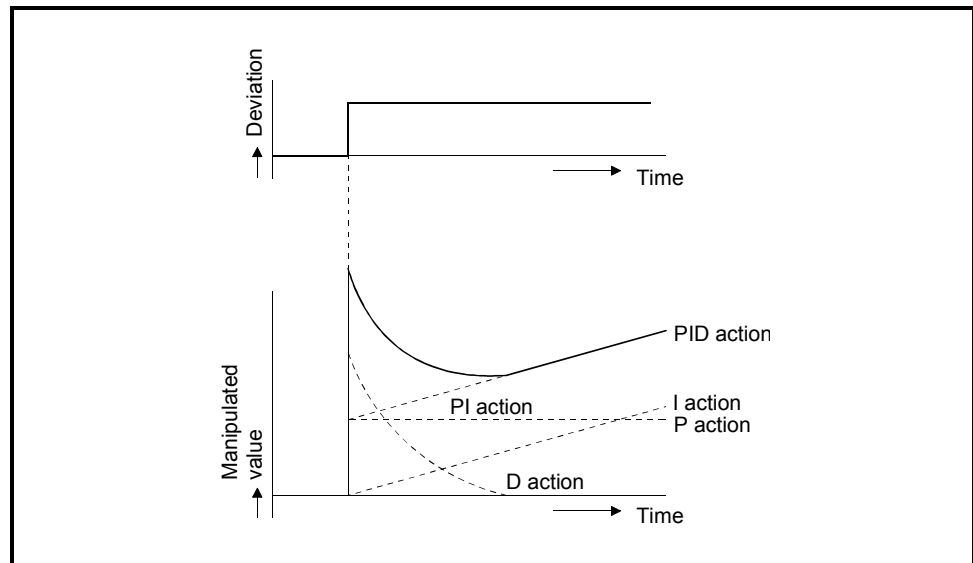

Fig. 1.11 PID action for step response

1.4 Functions Added to Function Version B and Later

(1) Functions added to the Q64TC of function version B

Function	Function summary	Reference section
Multiple CPU system support	Control from any desired programmable controller CPU by a multiple CPU system.	—
Auto tuning mode selection	Auto tuning mode selection corresponding to the response characteristics of the control object.	Section 3.5.47

(2) Functions added to the Q64TC of function version C

Function	Function summary	Reference section
Online module change	Change the module without stopping the system.	Chapter 7

POINT	Refer to Section 2.3 for the confirmation methods of the function version.
--------------	--

2 SYSTEM CONFIGURATION

This chapter explains the system configuration of the Q64TC.

2.1 Applicable Systems

This section describes the applicable systems.

(1) Applicable modules and base units, and No. of modules

(a) When mounted with a CPU module

The table below shows the CPU modules and base units applicable to the Q64TC and quantities for each CPU model.

Depending on the combination with other modules or the number of mounted modules, power supply capacity may be insufficient.

Pay attention to the power supply capacity before mounting modules, and if the power supply capacity is insufficient, change the combination of the modules.

Applicable CPU module		No. of modules *1		Base unit *2		
CPU type	CPU model	Q64TCTT/ Q64TCRT	Q64TCTTBW/ Q64TCRTBW	Main base unit	Extension base unit	
Programmable controller CPU	Basic model QCPU	Q00JCPU	Up to 16	Up to 8	○	○
		Q00CPU	Up to 24	Up to 12		
		Q01CPU				
	High Performance model QCPU	Q02CPU	Up to 64	Up to 32	○	○
		Q02HCPU				
		Q06HCPU				
		Q12HCPU				
		Q25HCPU				
	Process CPU	Q02PHCPU	Up to 64	Up to 32	○	○
		Q06PHCPU				
		Q12PHCPU				
		Q25PHCPU				
	Redundant CPU	Q12PRHCPU	Up to 53 * ³	Up to 26 * ³	×	○
		Q25PRHCPU				
	Universal model QCPU	Q00UJCPU	Up to 16	Up to 8	○	○
		Q00UCPU	Up to 24	Up to 12		
		Q01UCPU				
		Q02UCPU	Up to 36	Up to 18		
		Q03UDCPU	Up to 64	Up to 32		
		Q04UDHCPU				
Q06UDHCPU						
Q10UDHCPU						
Q13UDHCPU						
Q20UDHCPU						

○: Applicable, ×: N/A

Applicable CPU module		No. of modules *1		Base unit *2		
CPU type		Q64TCTT/ Q64TCRT	Q64TCTTBW/ Q64TCRTBW	Main base unit	Extension base unit	
Programmable controller CPU	Universal model QCPU	Q26UDHCPU	Up to 64	Up to 32	○	○
		Q03UDECPU				
		Q04UDEHCPU				
		Q06UDEHCPU				
		Q10UDEHCPU				
		Q13UDEHCPU				
		Q20UDEHCPU				
		Q26UDEHCPU				
		Q50UDEHCPU				
	Q100UDEHCPU					
	Safety CPU	QS001CPU	N/A	N/A	×	× *5
C Controller module		Q06CCPU-V	Up to 64 *4	Up to 32 *4	○	○
		Q06CCPU-V-B				
		Q12DCCPU-V				

○: Applicable, ×: N/A

- *1: Limited within the range of I/O points for the CPU module.
*2: Can be installed to any I/O slot of a base unit.
*3: Use the Q64TC whose serial No. (first five digits) is 09012 or later.
*4: Use the Q64TC of function version B or later.
*5: The safety CPU cannot be connected with extension base units.

REMARK

For the use of the C Controller module, refer to C Controller Module User's Manual.

(b) Mounting to a MELSECNET/H remote I/O station

The table below shows the network modules and base units applicable to the Q64TC and quantities for each network module model.

Depending on the combination with other modules or the number of mounted modules, power supply capacity may be insufficient.

Pay attention to the power supply capacity before mounting modules, and if the power supply capacity is insufficient, change the combination of the modules.

Applicable network module	No. of modules *1		Base unit *2	
	Q64TCTT/ Q64TCRT	Q64TCTTBW/ Q64TCRTBW	Main base unit of remote I/O station	Extension base unit of remote I/O station
QJ72LP25-25	Up to 64	Up to 32	○	○
QJ72LP25G				
QJ72LP25GE				
QJ72BR15				

○: Applicable, ×: N/A

*1: Limited within the range of I/O points for the network module.

*2: Can be installed to any I/O slot of a base unit.

Remark

The Basic model QCPU or C Controller module cannot create the MELSECNET/H remote I/O network.

(2) Support of the multiple CPU system

When using the Q64TC in a multiple CPU system, refer to the following manual first.

- QCPU User's Manual (Multiple CPU System)

(a) Compatible Q64TC

Use the Q64TC with function version B or higher if using the module in a multiple CPU system.

(b) Intelligent function module parameters

Write intelligent function module parameters to the control CPU of the Q64TC.

(3) Compatibility with online module change

To make an online module change, use the module of function version C or later.

POINT
The products of function version C include the functions of the products function versions A and B.

(4) Applicable software packages

Relation between the system containing the Q64TC and software package is shown in the following table.

GX Developer or GX Works2 is necessary when using the Q64TC.

		Software package				
		GX Developer	GX Configurator-TC	GX Works2		
Q00J/Q00/ Q01CPU	Single CPU system	Version 7 or later	Version 1.10L or later (the SW0D5C-QTCU-E 30D or earlier versions cannot be used).	Version 1.15R or later		
	Multiple CPU system	Version 8 or later				
Q02/Q02H/ Q06H/Q12H/ Q25HCPU	Single CPU system	Version 4 or later	SW0D5C-QTCU-E 00A or later			
	Multiple CPU system	Version 6 or later	SW0D5C-QTCU-E 30D or later			
Q02PH/ Q06PHCPU	Single CPU system	Version 8.68W or later	Version 1.13P or later (the SW0D5C-QTCU-E 30D or earlier versions cannot be used).		cannot be used	
	Multiple CPU system					
Q12PH/ Q25PHCPU	Single CPU system	Version 7.10L or later				
	Multiple CPU system					
Q12PRH/ Q25PRHCPU	Redundant system	Version 8.45X or later		Version 1.14Q or later (the SW0D5C-QTCU-E 30D or earlier versions cannot be used).		
Q00UJ/Q00U/ Q01UCPU	Single CPU system	Version 8.78G or later		Version 1.23Z or later (the SW0D5C-QTCU-E 30D or earlier versions cannot be used).		Version 1.15R or later
	Multiple CPU system					
Q02U/Q03UD/ Q04UDH/ Q06UDHCPU	Single CPU system	Version 8.48A or later				
	Multiple CPU system					
Q10UDH/ Q20UDHCPU	Single CPU system	Version 8.78G or later				
	Multiple CPU system					
Q13UDH/ Q26UDHCPU	Single CPU system	Version 8.62Q or later				
	Multiple CPU system					

		Software package		
		GX Developer	GX Configurator-TC	GX Works2
Q03UDE/ Q04UDEH/ Q06UDEH/ Q13UDEH/ Q26UDEHCPU	Single CPU system	Version 8.68W or later	Version 1.23Z or later (the SW0D5C-QTCU-E 30D or earlier versions cannot be used).	Version 1.15R or later
	Multiple CPU system			
Q10UDEH/ Q20UDEHCPU	Single CPU system	Version 8.78G or later		
	Multiple CPU system			
Q50UDEH/ Q100UDEHCPU	Single CPU system	cannot be used	cannot be used	Version 1.31H or later
	Multiple CPU system	cannot be used	cannot be used	
If installed in a MELSECNET/H remote I/O station		Version 6 or later	SW0D5C-QTCU-E 30D or later	Version 1.40S or later

(5) Current sensors

Only the following current sensors of URD, Ltd. are usable with the Q64TCTTBW and Q64TCRTBW.

- CTL-12-S36-8(0.0 to 100.0A)
- CTL-6-P-H(0.0 to 20.00A) (The conventional model CTL-6-P is also usable.)

2.2 For Use the Q64TC with Redundant CPUs

Here, use of the Q64TC with redundant CPUs is explained.

(1) GX Configurator-TC

GX Configurator-TC cannot be used when accessing the Redundant CPU via an intelligent function module on an extension base unit from GX Developer. Consider the communication path does not go through the intelligent function modules on the extension base unit.

Connect a personal computer to the Redundant CPU with a communication path indicated below.

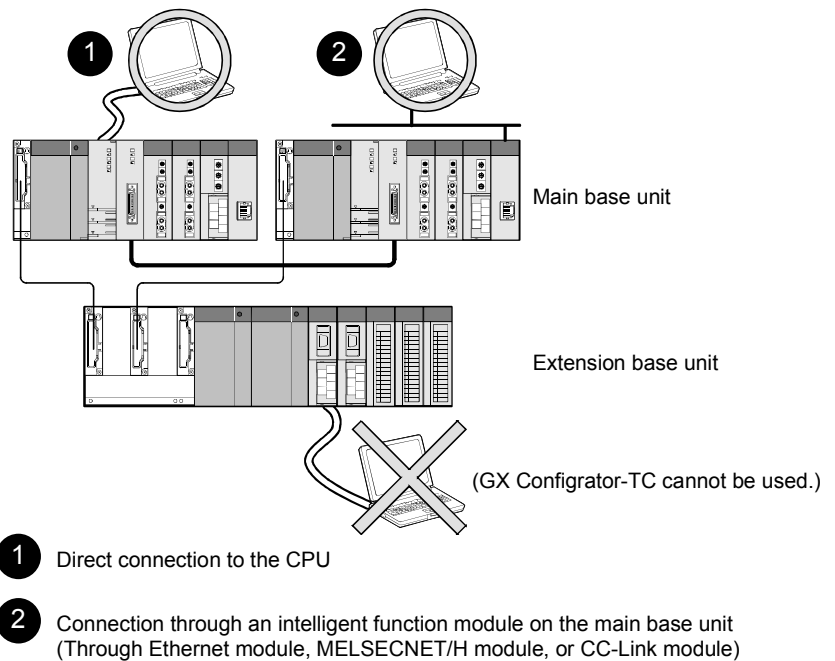

2.3 Checking Function Version/Serial No./Product Information/Software Version

This section describes how to check the function version of the Q64TC and the GX Configuration-TC software version.

(1) Checking the function version and serial number of the Q64TC

The serial number and function version of the Q64TC are described in the rating plate, on the front part of the module, or displayed in the system monitor of GX Developer.

(a) Checking the rating plate located on the side of the Q64TC

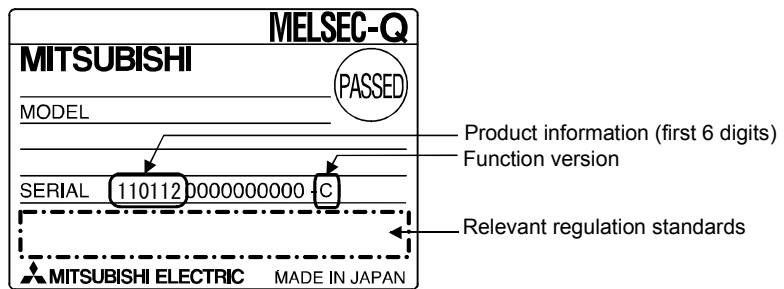

(b) Checking the front part of the module

The serial number and function version described in the rating plate can be shown on the front (bottom part) of the module.

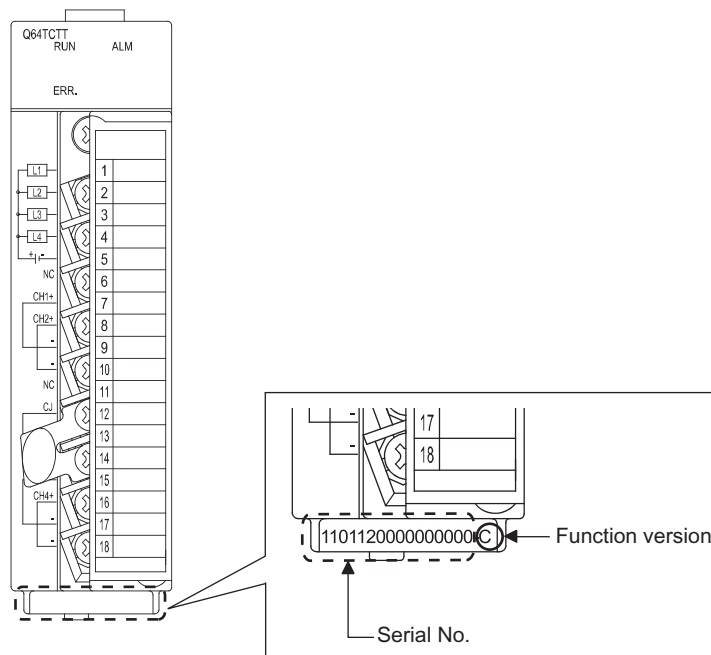

REMARK

The serial number is displayed on the front of the module from February 2009 production. Products manufactured during switching period may not have the serial number on the front of the module.

(c) Checking the system monitor (Product Information List)

To display the system monitor, select [Diagnostics] → [System monitor] and click the Product Information List button of GX Developer.

Slot	Type	Series	Model name	Points	I/O No.	Master PLC	Serial No.	Ver.	Product No.
PLC	PLC	Q	Q06UDHCPU	-	-	-	1101300000000000	B	091013092955015-B
0-0	Intelli.	Q	Q64TCTT	16pt	0000	-	1007100000000000	C	-
0-1	-	-	None	-	-	-	-	-	-
0-2	-	-	None	-	-	-	-	-	-
0-3	-	-	None	-	-	-	-	-	-
0-4	-	-	None	-	-	-	-	-	-

1) Displaying the product No.

Since the Q64TC does not support the display function, "-" is displayed in the "Product No." field.

POINT

The serial number displayed on the Product Information List screen of GX Developer may differ from that on the rating plate and on the front of the module.

- The serial number on the rating plate and front part of the module indicates the management information of the product
- The serial number displayed on the Product Information List dialog box of GX Developer indicates the function information of the product.
The function information of the product is updated when a new function is added.

(2) Checking the software version of GX Configurator-TC

The software version of GX Configurator-TC can be checked by selecting [Help] → [Product information] of GX Developer.

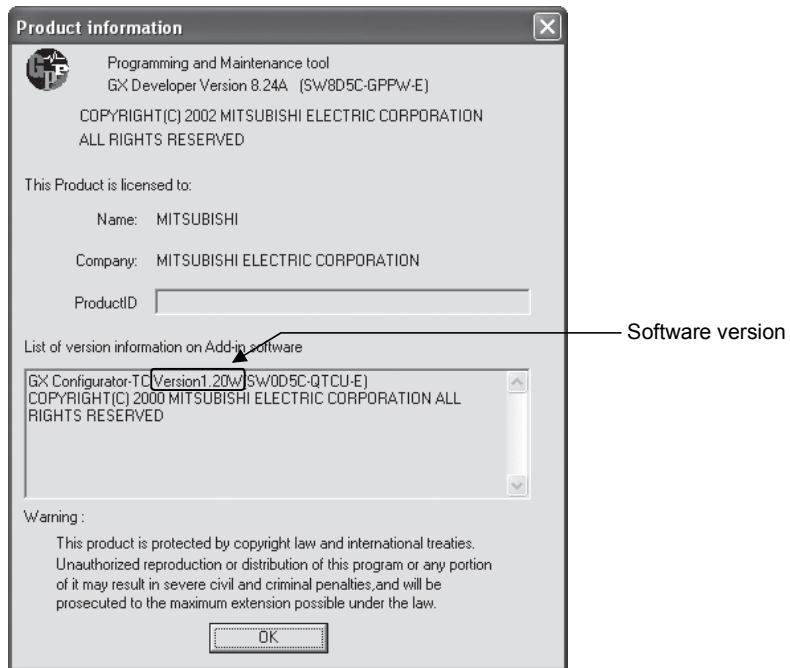

(In the case of GX Developer Version 8)

REMARK

The version indication for the GX Configurator-TC has been changed as shown below from the SW0D5C-QTCU-E 30D upgrade product.

Previous product	Upgrade and subsequent versions
SW0D5C-QTCU-E 30D	→ GX Configurator-TC Version 1.10L

2.4 Precautions for System Configuration

The Q64TC measures a temperature on the basis of the temperature of a terminal block. Therefore, depending on a system configuration (especially for the case when two or more the Q64TC are mounted side by side, or when the Q64TC is mounted next to the power supply module or the CPU module), the temperature distribution of the terminal block becomes inhomogeneous because of the effect of heat emitted from each module, thus the measured temperature error may become large. In such case, use a terminal block converter module and a dedicated cable shown below to prevent the error caused by the heat emission.

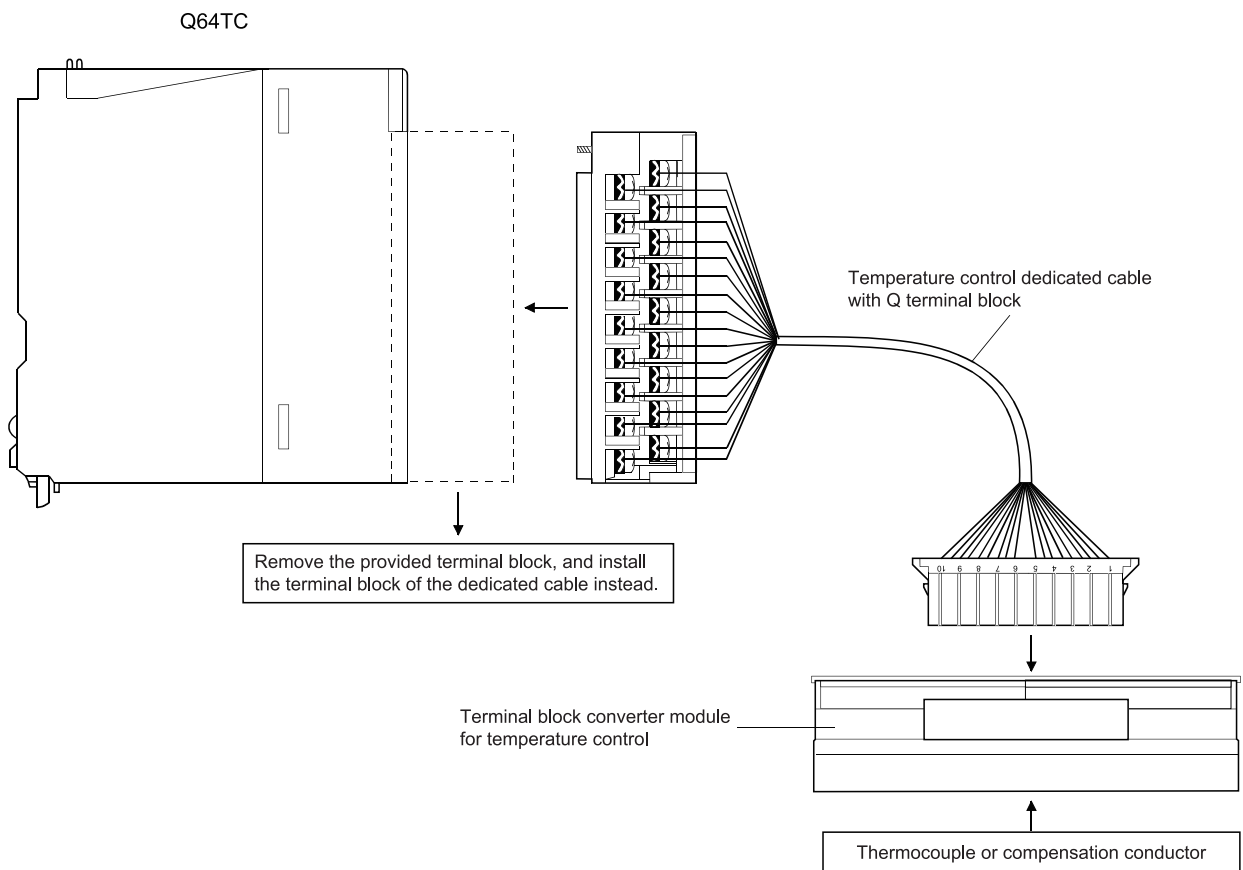

The following table lists the dedicated cable and the terminal block converter module.

Product name	Model	Manufacturer
Temperature control dedicated cable with Q terminal block	FA-CBLQ64TC** (**: Cable length)	Mitsubishi Electric Engineering Co., Ltd.
Terminal block converter module for temperature control	FA-TB20TC	

For inquiries related to the products or your order, please consult your local Mitsubishi Electric sales office or representative.

3 SPECIFICATIONS

This chapter provides the performance specifications of the Q64TC, I/O signals transferred to/from the programmable controller CPU and the specifications of buffer memory.

For the general specifications of the Q64TC, refer to the User's Manual (hardware) of the CPU module used.

3.1 Performance Specifications

3.1.1 Performance specifications of the Q64TC

Table 3.1 Q64TC performance specification list

			Specifications			
			Q64TCTT	Q64TCRT	Q64TCTTBW	Q64TCRTBW
Control output			Transistor output			
Number of temperature input points			4 channels/module			
Usable thermocouples/platinum temperature-measuring resistors			Refer to Section 3.1.2.			
Acc- uracy * 1	Indication accuracy	Ambient temperature: 25°C±5°C	Full-scale x (±0.3%)			
		Ambient temperature: 0 to 55°C	Full-scale x (±0.7%)			
	Cold junction temperature compensation accuracy (Ambient temperature: 0 to 55°C)	Temperature process value: -100°C or more	Within ±1.0°C	—	Within ±1.0°C	—
		Temperature process value: -150 to -100°C	Within ±2.0°C		Within ±2.0°C	
Temperature process value: -200 to -150°C		Within ±3.0°C	Within ±3.0°C			
Sampling period			0.5s/4 channels (constant independently of the number of channels used)			
Control output period			1 to 100s			
Input impedance			1M Ω			
Input filter			0 to 100s (0: Input filter off)			
Sensor compensation value setting			-50.00 to 50.00%			
Operation at sensor input disconnection			Upscale processing			
Temperature control system			PID ON/OFF pulse or 2-position control			
PID constant range	PID constant setting		Setting can be made by auto tuning			
	Proportional band (P)		0.0 to 1000.0% (0: 2-position control)			
	Integral time (I)		1 to 3600s			
	Derivative time (D)		0 to 3600s (set 0 for PI control.)			
Set value setting range			Within temperature range set to the used thermocouple/platinum temperature-measuring resistor			
Dead band setting range			0.1 to 10.0%			
Transistor output	Output signal		ON/OFF pulse			
	Rated load voltage		10 to 30VDC			
	Max. load current		0.1A/point, 0.4A/common			
	Max. inrush current		0.4A 10ms			
	Leakage current at OFF		0.1mA or less			
	Max. voltage drop at ON		1.0VDC (TYP) 0.1A 2.5VDC (MAX) 0.1A			
	Response time		OFF→ON: 2ms or less, ON→OFF: 2ms or less			
E ² PROM write count			Max. 100 thousand times			
Insulation method			Between input and grounding : Transformer insulation Between input and channel : Transformer insulation			
Dielectric strength			Between input and grounding : 500VAC for 1 minute Between input and channel : 500VAC for 1 minute			
Insulation resistance			Between input and grounding : 500VDC 20M Ω or more Between input and channel : 500VDC 20M Ω or more			

		Specifications			
		Q64TCTT	Q64TCRT	Q64TCTTBW	Q64TCRTBW
Heater disconnection detection specifications	Current sensor	_____		Refer to Section 2.1	
	Input accuracy			Full scale x (±1.0%)	
	Alert delay count			3 to 255	
I/O occupied points *2		16 points/slot (I/O assignment: 16 intelligent points)		32 points/2 slots (Default I/O assignment : 16 free points + 16 intelligent points)	
Connection terminal		18-point terminal block		Two 18-point terminal blocks	
Applicable wire size		0.3 to 0.75mm ²			
Applicable crimping terminal		R1.25-3, 1.25-YS3, RAV1.25-3, V1.25-YS3A			
Internal current consumption		0.55A		0.64A	
Weight		0.20kg		0.30kg	
Outline dimensions		27.4mm(1.08in.)(W)×98mm(3.86in.)(H) ×112mm(4.41in.)(D)		55.2mm(2.17in.)(W)×98mm(3.86in.)(H) ×112mm(4.41in.)(D)	

- *1: Calculate the accuracy in the following method.
 (Accuracy) = (indication accuracy) + (cold junction temperature compensation accuracy)
 Example) Accuracy at the input range of "38", operating ambient temperature of 35°C and temperature process value of 300°C

$$\{400.0 - (-200.0)\} [\text{Full-scale}] \times (\pm 0.007) [\pm 0.7\%] + (\pm 1.0^\circ\text{C}) [\text{Cold junction temperature compensation accuracy}] = \pm 5.2^\circ\text{C}$$
- *2: When the Q64TCTTBW or Q64TCRTBW is used, the device numbers of the I/O signals increase by 16 points depending on how many free points the left-hand side slots have.
 Hence, as I/O signals are given as indicated below in this manual, read them according to the module used.
 Example) When a signal is given as Yn1
 When the Q64TCTT or Q64TCRT is used: Y1 When the Q64TCTTBW or Q64TCRTBW is used: Y11
- *3: For the noise immunity, dielectric withstand voltage, insulation resistance and others of the programmable controller system which uses this module, refer to the power supply module specifications given in the User's Manual of the CPU module used.

3.1.2 Usable temperature sensor types, measurement temperature ranges and data resolutions

(1) For use of the Q64TCTT(BW)

Table 3.2 Thermocouple type, measurement temperature range and data resolution list

Thermocouple type	°C		°F	
	Measurement temperature range	Data resolution	Measurement temperature range	Data resolution
R	0 to 1700	1	0 to 3000	1
K	0 to 500	1	0 to 1000	1
	0 to 800		0 to 2400	
	0 to 1300			
	-200.0 to 400.0	0.1	0.0 to 1000.0	0.1
J	0.0 to 400.0	1	0.0 to 1000.0	1
	0.0 to 500.0		0.0 to 1600	
	0.0 to 800.0		0.0 to 2100	
	0.0 to 400.0	0.1	0.0 to 1000.0	0.1
T	-200 to 400	1	0 to 700	1
	-200 to 200		-300 to 400	
	0 to 200			
	0 to 400	0.1	0.0 to 700.0	0.1
S	-200.0 to 400.0			
	0.0 to 400.0			
S	0 to 1700	1	0 to 3000	1
B	0 to 1800	1	0 to 3000	1
E	0 to 400	1	0 to 1800	1
	0 to 1000			
N	0.0 to 700.0	0.1	————	————
	0 to 1300	1	0 to 2300	1
U	0 to 400	1	0 to 700	1
	-200 to 200		-300 to 400	
	0.0 to 600.0	0.1	————	————
L	0 to 400	1	0 to 800	1
	0 to 900		0 to 1600	
	0.0 to 400.0	0.1	————	————
	0.0 to 900.0			
PL II	0 to 1200	1	0 to 2300	1
W5Re/W26Re	0 to 2300	1	0 to 3000	1

(2) For use of the Q64TCRT(BW)

Table 3.3 Usable platinum temperature-measuring resistors, measurement temperature ranges and data resolutions

Platinum temperature-measuring resistor type	°C		°F	
	Measurement temperature range	Data resolution	Measurement temperature range	Data resolution
Pt100	-200.0 to 600.0	0.1	-300 to 1100	1
	-200.0 to 200.0		-300.0 to 300.0	0.1
JPt100	-200.0 to 500.0	0.1	-300 to 900	1
	-200.0 to 200.0		-300.0 to 300.0	0.1

3.2 Function Summary

The Q64TC function summary is shown in Table 3.4.

Table 3.4 Q64TC function summary

Item	Specification	Reference
Auto-tuning function	• The temperature control module automatically sets the optimal PID constants.	3.2.1
Forward action/reverse action selection function	• Heat control (reverse action) or cooling control (forward action) can be selected and controlled.	3.2.2
RFB limiter function	• Limit the manipulation value overshoot which frequently occurs when the set value (SV) is changed or control target is changed.	3.2.3
Sensor compensation function	• Reduces the difference between the measured value and actual temperature to zero when these two are different due to measurement conditions, etc.	3.2.4
Unused channel setting	• Sets the PID operation for channels that do not perform temperature adjustment to "not execute."	3.2.5
PID control forced stop	• Stops the PID operation for channels that is performing temperature adjustment.	3.2.6
Heater disconnection detection function	• Measures the current that flows in the heater main circuit and detects disconnection when the Q64TCTTBW or Q64TCRTBW is used.	3.2.7
Current error detection function when output is off	• When the Q64TCTTBW or Q64TCRTBW is used, this function measures the current in the heater's main circuit while the transistor's output is off, and checks if there is a current error when output is off.	3.2.8
Loop disconnection detection function	• A function to detect errors in the control system (control loop) caused by a load (heater) disconnection, abnormal external operation device (such as magnet relay), or a thermocouple disconnection.	3.2.9
Data storage on E ² PROM	• By backing up the buffer memory contents to E ² PROM, the load of sequence program can be reduced.	3.2.10
Alert function	• Monitors the process value (PV) and alerts the user.	3.2.11
Control output setting at CPU stop error occurrence	• This function continues/stops temperature adjustment control output at CPU stop error occurrence.	3.2.12
Q64TC control status	• The Q64TC can be controlled by the output signal of the Q64TC and the settings in the buffer memory.	3.2.13
Online module change	• A module change is made without the system being stopped.	Chapter 7

3.2.1 Auto tuning function

(1) What is the auto tuning function?

- (a) The auto tuning function is designed for the Q64TC to set the optimum PID constants automatically.

In auto tuning, the PID constants are calculated according to the hunting cycle and amplitude which take place when a manipulated value turned on/off alternates between overshooting and undershooting a set value.

- (b) Setting the following data enables auto tuning to be executed. Note that since actual control starts on completion of auto tuning, the other data should be preset to the values used for actual operation.

*When "0" has been set to the proportional band (P), auto tuning is not executed.

Buffer memory address name	Address (Hexadecimal)			
	CH1	CH2	CH3	CH4
Input range	20H	40H	60H	80H
Set value (SV) setting	22H	42H	62H	82H
Upper output limiter	2AH	4AH	6AH	8AH
Lower output limiter	2BH	4BH	6BH	8BH
Output variation limiter	2CH	4CH	6CH	8CH
Sensor compensation value setting	2DH	4DH	6DH	8DH
Control output period setting	2FH	4FH	6FH	8FH
Primary delay digital filter setting	30H	50H	70H	90H
AUTO/MAN mode switch	32H	52H	72H	92H
AT bias	35H	55H	75H	95H
Forward/reverse action setting	36H	56H	76H	96H
Auto tuning mode selection	B8H	B9H	BAH	BBH

- (c) On completion of auto tuning, calculated values are set to the following buffer memory addresses.

Buffer memory address name	Address (Hexadecimal)			
	CH1	CH2	CH3	CH4
Proportional band (P) setting	23H	43H	63H	83H
Integral time (I) setting	24H	44H	64H	84H
Derivative time (D) setting	25H	45H	65H	85H
Loop disconnection detection judgment time *1	3BH	5BH	7BH	9BH

*1: As the loop disconnection detection judgment time, a value twice greater than the calculated integral time is set. However, the loop disconnection detection judgment time remains unchanged from 0 when it is 0 at an auto tuning start.

(2) Executing auto-tuning

(a) Auto tuning is performed in the following procedure.

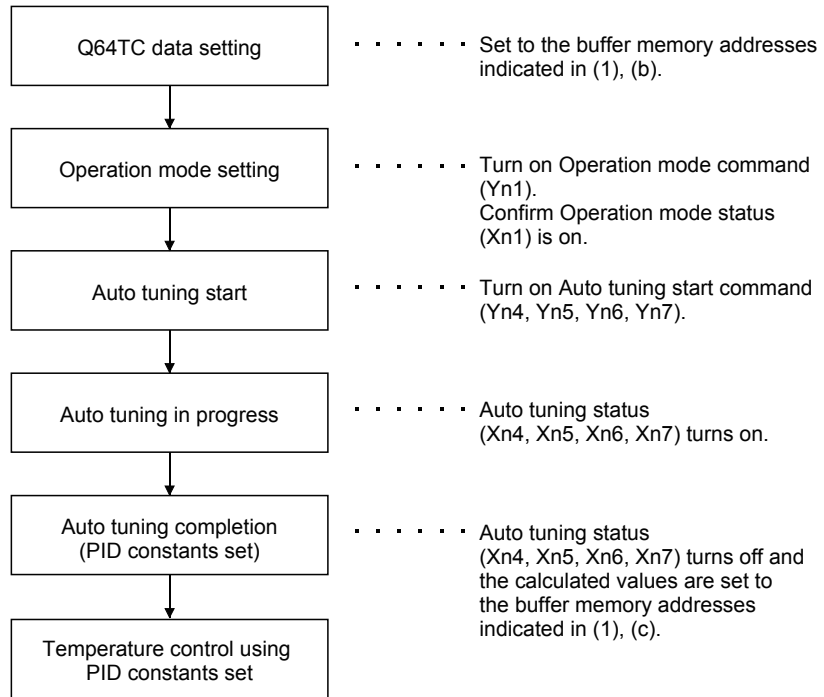

(b) Conditions for starting auto-tuning

When any of the following conditions is met, auto-tuning is not executable.

- 1) The Operation mode status (Xn1) is off (setting mode).
- 2) In Proportional band (P) setting (buffer memory address: 23H, 43H, 63H, 83H), 0 is set. (2-position control)
- 3) In AUTO/MAN mode switching (buffer memory address: 32H, 52H, 72H, 92H), 1 (Manual) is set.
- 4) In Unused channel setting (buffer memory address: 3DH, 5DH, 7DH, 9DH), 1 (Unused) is set for the channel.
- 5) Forced PID control stop command (YnC to YnF) is on.
- 6) Hardware failure is identified. (The ERR. LED turns on.)
- 7) Temperature process value (PV) (buffer memory address: 9H to CH) exceeds the measured temperature range (Refer to Section 3.5.4).
- 8) In E²PROM's PID constant read command (buffer memory address: 3EH, 5EH, 7EH, 9EH), 1 (With command) is set.
- 9) A bit of write flag in E²PROM's PID constant read/write completion flag (buffer memory address: 1FH) is on.

For conditions 1) to 5), auto-tuning starts as soon as the condition is changed.

For conditions 6) and 7), Auto tuning status (Xn4 to Xn7) turns on momentarily. The auto tuning does not start until Auto tuning command (Yn4 to Yn7) turns from off to on again even if the condition is changed.

For conditions 8) and 9), even if internal processing of auto tuning is completed and PID constant is stored, Auto tuning status (Xn4 to Xn7) does not turn off and auto tuning is not completed.

POINT
<p>After powering off the programmable controller CPU, you can use the set PID constants in the following method.</p> <ul style="list-style-type: none"> • Write the values directly to the buffer memory using the sequence program. • Store the PID constants into E²PROM and transfer them when powering on the programmable controller CPU. • Use the initial settings of the GX Configurator-TC.

(c) Auto tuning operation

Auto tuning performs operation as shown below.

- 1) Auto tuning output is provided.
- 2) Data collection starts when the process value returns to the set value after the first overshoot and undershoot.
- 3) After data collection, auto tuning ends when PID constants and loop disconnection detection judgment time are set.

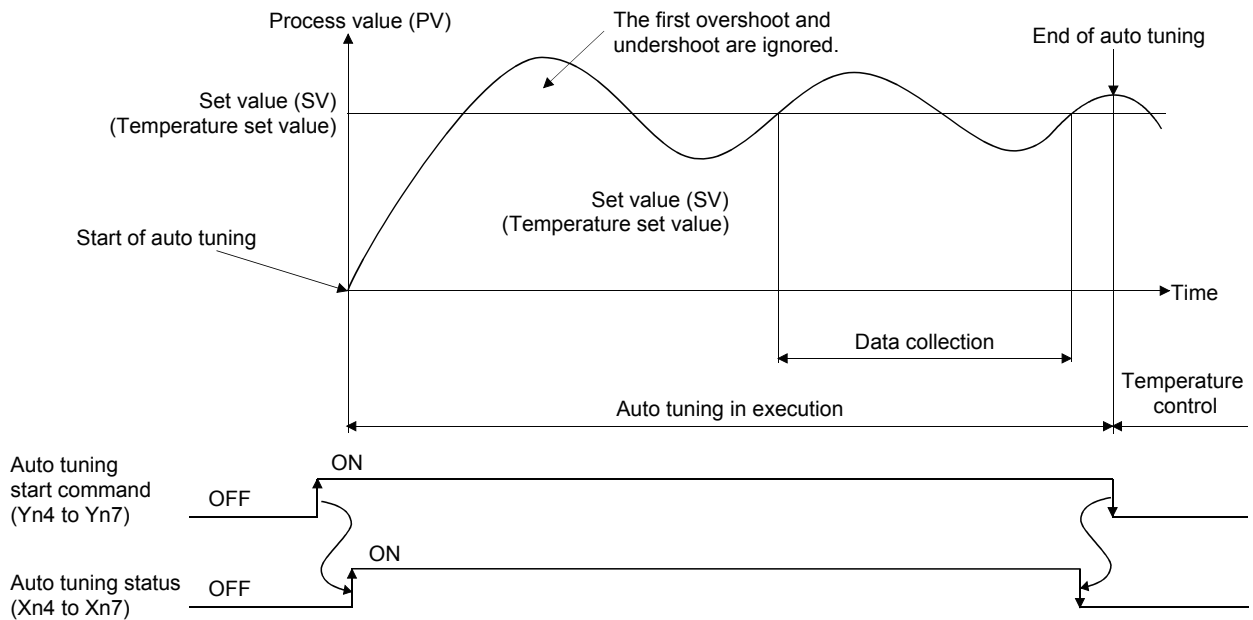

(d) Precautions for auto tuning

The following indicate the conditions under which auto tuning will result in abnormal termination.

- 1) Operation mode command (Yn1) has been turned off. (Except for the case where PID continuation flag (buffer memory address: A9H) is "Continue".)
- 2) Any of the following setting items for the channel has been changed during execution of auto-tuning.

Setting item	Buffer memory address (Hexadecimal)			
	CH1	CH2	CH3	CH4
Set value (SV) setting	22H	42H	62H	82H
Upper output limiter	2AH	4AH	6AH	8AH
Lower output limiter	2BH	4BH	6BH	8BH
Sensor compensation value setting	2DH	4DH	6DH	8DH
Primary delay digital filter setting	30H	50H	70H	90H
AUTO/MAN mode switching	32H	52H	72H	92H
AT bias	35H	55H	75H	95H
Forward/reverse action setting	36H	56H	76H	96H
Unused channel setting	3DH	5DH	7DH	9DH

- 3) Temperature process value (PV) (buffer memory address: 9H to CH) exceeds the measured temperature range (refer to section 3.5.4).
- 4) The following time exceeds 2 hours.
 - Time elapsed from the auto-tuning start until the set value is reached at the first time.
 - A half of the hunting cycle
The value calculated by PID constants after auto-tuning exceeds any of the following ranges.
- 5) Proportional section (P): 0.1 to 1000.0 (%)
Integral time (I): 1 to 3600 (s)
Derivative time (D): 0 to 3600 (s)
- 6) Forced PID control stop command (YnC to YnF) has been turned on.
- 7) Hardware failure has occurred.
- 8) Proportional band (P) setting (buffer memory address: 23H, 43H, 63H, 83H) has been changed to 0. (2-position control)
- 9) Upper setting limiter (buffer memory address: 37H, 57H, 77H, 97H) or Lower setting limiter (buffer memory address: 38H, 58H, 78H, 98H) has been changed and thereby the set value (SV) is outside the setting range.

- (3) Operation at termination of auto tuning
 - (a) Operation at normal termination
 - Auto tuning status (Xn4 to Xn7) turns off.
 - The PID constants are set.
 - Loop disconnection detection judgment time (buffer memory address: 3BH, 5BH, 7BH, 9BH) is set. (If the loop disconnection detection judgment time is 0 at the start of auto tuning, it remains unchanged from 0.)
 - (b) Operation at abnormal termination
 - Auto tuning status (Xn4 to Xn7) turns off.
 - The PID constants are not set.
- (4) Adjustment after auto tuning
 - (a) Specific readjustment is not needed for the PID constants calculated by auto tuning.
 - (b) Use Control response parameter (buffer memory address: 31H, 51H, 71H, 91H) to change the control response for the PID constants calculated by auto tuning.

REMARK

- 1) The time between the start and completion of auto tuning depends on the object to be controlled.
- 2) You can confirm that auto tuning has been completed by checking that Auto tuning status (Xn4 to Xn7) has turned from on to off.
- 3) At the start of an auto tuning, if Automatic backup setting after auto tuning of PID constants (buffer memory address: 3FH, 5FH, 7FH, 9FH) is preset to be valid, the PID constants and loop disconnection detection judgment time are automatically backed up by E²PROM on completion of auto tuning.

3.2.2 Reverse/Forward action select function

With the Q64TC, "reverse action" or "forward action" can be selected to perform the PID operations.

(1) Q64TC default

The default is set at "reverse action" for the Q64TC.

When performing the PID operations with the "forward action," set to the forward action in Forward/reverse action setting (buffer memory address: 36H, 56H, 76H, 96H).

(2) Reverse/forward action control details

(a) Reverse action : Used for heating control to increase temperature.

(b) Forward action : Used for cooling control to decrease temperature.

3.2.3 RFB limiter function

(1) RFB(Reset feed back) limiter function

The RFB limiter function limits the PID operation result (manipulated value: MV) not to exceed the valid range by the integral control action when an error continues for a long time.

With the RFB limiter function, if the PID operation result exceeds the upper/lower output limiter value, the amount exceeded is fed back to the integral value and the PID operation result is kept at the limit value.

3.2.4 Sensor compensation function

(1) Sensor compensation function

The sensor compensation function compensates the difference between the temperature process value and actual temperature caused by measurement conditions.

(2) Sensor compensation value setting

When there is a difference between the temperature process value and actual temperature, the full-scale percentage (-50.00 to 50.00%) is set in Sensor compensation value setting (buffer memory address: 2DH, 4DH, 6DH, 8DH) as the sensor compensation value.

For example, when the input range is at -200°C to 200°C and there is a 2°C error, the full-scale is 400°C (200°C-(-200°C)=400°C).

Therefore, $2/400 \times 100 = 0.5\%$ is set. ("50" is set in the buffer memory.)

3.2.5 Unused channel setting

(1) Channels where temperature sensors are not connected

The Q64TC performs upscale processing on the channels where temperature sensors (thermocouples/platinum temperature-measuring resistors) are not connected.

Hence, when a temperature sensor is not connected to the channel which will not exercise temperature control, the PV value is judged as higher than the temperature measurement range of the input range, and the "ALM" LED is lit by alert processing.

(2) Unused channel setting

(a) To make unused channel setting, write "1" to Unused channel setting (buffer memory address: 3DH, 5DH, 7DH, 9DH).

(b) After the unused channel setting has been made, no alert will occur at the channel with no temperature sensor connected and the "ALM" LED will not be lit.

The sampling period remains unchanged if the unused channel setting is performed.

3.2.6 Forced PID control stop

(1) Forced PID control stop

Forced PID control stop is a function to stop PID operations temporarily from the programmable controller CPU.

The action to be taken by the Q64TC at a PID operation stop depends on the setting of Stop mode setting (buffer memory address: 21H, 41H, 61H, 81H).

(2) Executing forced PID control stop

To execute a forced PID control stop, turn on Forced PID control stop command (YnC to YnF).

At this time, Manipulated value (MV) (buffer memory address: DH to 10H) is -50 (-5.0%).

(3) Cancelling forced PID control stop

When Forced PID control stop command (YnC to YnF) is turned off, a forced PID control stop is cancelled and PID operations are resumed at the manipulated value which was output during the forced PID control stop.

POINT
Setting the programmable controller CPU to the STOP status turns off Forced PID control stop command (YnC to YnF), "cancelling the forced PID control stop".

3.2.7 Heater disconnection detection function (available for the Q64TCTTBW, Q64TCRTBW only)

(1) Heater disconnection detection function

- (a) This is a function to check if there is a heater wire breakage using the reference heater current value (load current value detected by the current sensor (CT)), when the transistor output is on.
- (b) The heater disconnection detection function compares the current values of reference heater and heater disconnection alert, and determines that there is a heater wire breakage when the current value of reference heater is below that of heater disconnection alert.
However, when the transistor turned-on time is less than 0.5 seconds, the heater disconnection detection is not performed.
- (c) By restoring the disconnection, Alert definition (buffer memory address: 5H to 8H) turns off the disconnection detection.
However, when setting CT monitor method switching (buffer memory address: B0H) to "1: ON current", the disconnection detection does not turn off unless the heater turns on ("OUT" LED on the front of the module is lit). The timing of turning on the heater differs according to Control output period setting (buffer memory address: 2FH, 4FH, 6FH, 8FH).
- (d) The following shows setting procedures for the heater disconnection detection function.
- 1) Set current sensor (CT) to be used to CT selection (buffer memory address: 110H to 117H).
 - 2) Set CT input to be assigned for each channel to CT input channel assignment setting (buffer memory address: 108H to 10FH).
 - 3) Monitor the Heater current process value (buffer memory address: 100H to 107H) and check a value of current that flows while the heater is on.
 - 4) Set a value monitored in 3) to Reference heater current value (buffer memory address: 118H to 11FH).
 - 5) Set a value to judge whether to perform heater disconnection detection and output off-time current error detection by percent (%) of the reference heater current value in the Heater disconnection alert setting (buffer memory address: 3AH, 5AH, 7AH, 9AH). *1
 - 6) Set 1 (ON current) in CT monitor method switching (buffer memory address: B0H) when not to detect current error while the output is OFF.
 - 7) Set whether to use the heater disconnection compensation function in the Heater disconnection compensation function selection (buffer memory address: AAH).
 - 8) Set the number of consecutive occurrences of heater disconnection detection that becomes a trigger to give an alert in the Heater disconnection/output off-time current error detection delay count (buffer memory address: A6H).

POINT
Although standard setting value of the heater disconnection alert setting of *1 is 80%, variation of the current value may be increased depending on operating status or characteristics of the heater. Fully make sure that no problem occurs in the actual system.

(2) Heater disconnection compensation function

(a) Heater disconnection compensation

When the heater voltage drops, the heater current decreases as well.

The Q64TCTTBW, Q64TCRTBW heater disconnection detection measures the heater current and determines the heater disconnection.

Therefore, when the heater voltage drops, there are possibilities that a false alarm may be set due to the voltage change.

Therefore, the Q64TCTTBW, Q64TCRTBW compensates for a drop in heater current (heater breakage compensation) so that the drop in heater current does not activate the break detection.

(b) Heater disconnection compensation method

The heater disconnection compensation calculates "the heater current for each channel" - "reference heater current value," and the largest positive value is set as the compensation value.

When there is no positive values, the value with the smallest negative value is used as the compensation value.

The heater current for each channel is compensated with the compensation value and a heater disconnection is detected when the compensated value exceeds the specified heater disconnection alert setting value.

Example 1: When the difference from the reference heater current value is: Channel 1: -2%, Channel 2: 5%, Channel 3: -1%, Channel 4: -17%, the compensation value becomes 5%.

The heater disconnection detection is performed from the values after a 5% compensation: Channel 1: -7%, Channel 2: 0%, Channel 3: -6%, Channel 4: -22%.

Thus, when the heater disconnection alert setting value is at 80%, only channel 4 is detected as disconnected.

Channel No.	Heater disconnection detection setting value	Difference from the standard current	Compensation value	Difference from the standard current after compensation	Disconnected
1	80%	-2%	5%	-7%	No
2		5%		0%	No
3		-1%		-6%	No
4		-17%		-22%	Yes

Example 2: The difference from the reference heater current value is:

Channel 1: -16%, Channel 2: -17%, Channel 3: -22%, Channel 4: -19%, the compensation value becomes -16%.

The heater disconnection detection is performed from the values after a -16% compensation: Channel 1: 0%, Channel 2: -1%, Channel 3: -6%, Channel 4: -3%.

Thus, when the heater disconnection alert setting value is at 80%, none of the channels are detected as disconnected.

Channel No.	Heater disconnection detection setting value	Difference from the standard current	Compensation value	Difference from the standard current after compensation	Disconnected
1	80%	-16%	-16%	0	No
2		-17%		-1%	No
3		-22%		-6%	No
4		-19%		-3%	No

(c) Restrictions

- The heater-disconnection compensation function will not work if only one channel is used.
- The heater-disconnection compensation function will not work if only one channel is used to keep the heater on while the others are used to keep it off. The module may detect a disconnection even when the heater is not disconnected.
- The heater disconnection detection compensation value is up to 20%. Therefore, when there is a voltage drop by more than 40%, a disconnection is detected even with a 20% compensation.

3.2.8 Output off-time current error detection function (available for the Q64TCTTBW and Q64TCRTBW only)

- (1) Using the reference heater current value (load current value detected by the current sensor (CT)), this function checks for a transistor output off-time current error when the transistor output is off.
- (2) The transistor output off-time current error detection function compares the reference heater current value and the current value of the heater disconnection alert, and judges it as an output off-time current error if the reference heater current value is higher than the current value of the output off-time current alert.
Note that output off-time current error detection will not be made if the transistor output off period is within 0.5 seconds.

3.2.9 Loop disconnection detection function

The loop disconnection detection function detects errors in the control system (control loop) caused by a load (heater) disconnection, external operation device (e.g. magnetic relay) fault, input disconnection and others.

When the PID operation value has reached 100% or 0%, this function starts monitoring the variation of the process value per loop disconnection detection judgment time to detect a heater or input disconnection.

- (1) When the heater is disconnected, when the input is disconnected or shorted, or when the external operation device contact does not turn on, it is judged as an error since the temperature will not rise despite the control output provided.
In this case, an alert is output if a temperature rise of 2°C or more is not observed within the preset loop disconnection detection judgment time after the control output is provided 100%.
- (2) When the input is disconnected or when the external operation device contact is welded, it is judged as an error since the temperature will rise though the control output is not provided.
In this case, an alert is output if a temperature fall of 2°C or more is not observed within the preset loop disconnection detection judgment time after the control output has dropped to 0%.
(In either case, inverse operation will be performed for forward action: cooling control.)

POINT
<p>(1) When not using the loop disconnection detection function, set the loop disconnection detection judgment time to "0".</p> <p>(2) Setting the loop disconnection detection dead band will not cause a loop disconnection if there is no temperature variation of 2°C or more when the control output is provided 100% or 0% at the set value. (Refer to Section 3.5.32.)</p>

3.2.10 Data storage on E²PROM(1) Data storage on E²PROM

(a) The Q64TC buffer memory data can be stored onto E²PROM for backup.

The whole write-enabled area of the buffer memory can be backed up. Refer to Section 3.5 for details of the buffer memory.

Buffer memory backed-up address (Hexadecimal)				Remarks	
20H to 38H	40H to 58H	60H to 78H	80H to 98H	_____	
3AH to 3DH	4AH to 5DH	6AH to 7DH	8AH to 9DH		
A4H to AAH					
AFH					
B0H					
B5H					
C0H to C3H	D0H to D3H	E0H to E3H	F0H to F3H		
108H to 11FH					
					Q64TCTTBW, Q64TCRTBW only

Write to E²PROM can be used to back up the PID constants set by auto tuning and the data written directly to the buffer memory using a peripheral device.

Write to E²PROM eliminates the program used to set data to the Q64TC.

(b) The backed up data is transferred from E²PROM to buffer memory when the programmable controller CPU is powered on (power is switched on) or reset. Hence, temperature control can be exercised without data being written when the programmable controller CPU is powered on or reset.

(2) Writing data to E²PROM

- (a) When writing data to E²PROM, turn on E²PROM backup command (Yn8).
- E²PROM write completion flag (Xn8) turns on at completion of data write to E²PROM.
 - E²PROM write failure flag (XnA) turns on if write of data to E²PROM is not completed normally.
- (b) Make changes to buffer memory when the E²PROM write completion flag is off.

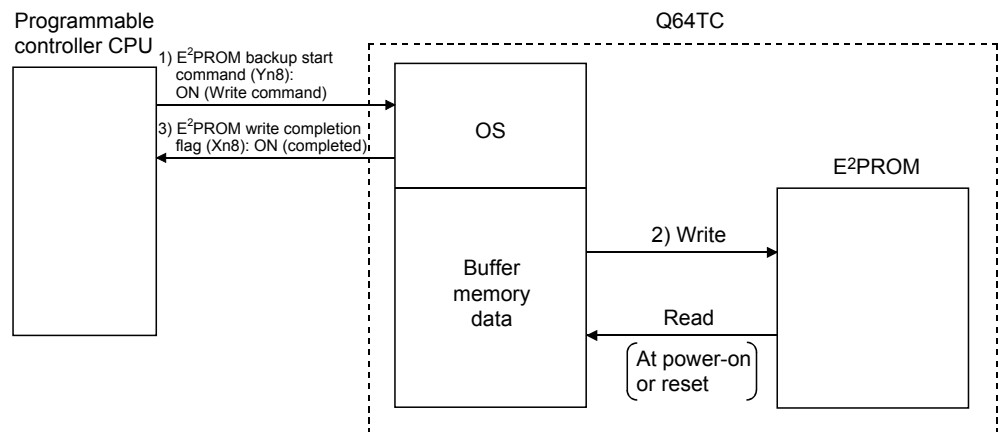

(3) Reading data from E²PROM

- E²PROM data read occurs under either of the following conditions.
- When the programmable controller CPU is powered on or reset.
 - When E²PROM's PID constant read command (3EH, 5EH, 7EH, 9EH) turns on.
- Note that the read data are only the PID constants and loop disconnection detection judgment time of the corresponding channel.

3.2.11 Alerts function

(1) The alerts is a function which sets the system in an alert status when the process value (PV) or deviation reaches the alert set value. It is used to turn on the device's hazard signal or operate the safety device.

The alerts is classified as follows:

- Input alerts functionUpper limit input alert, lower limit input alert
- Deviation alerts functionUpper limit deviation alert, lower limit deviation alert, upper/lower limit deviation alert, within-range alert

(a) Input alerts

1) Upper limit input alert

When the process value (PV) is equal to or greater than the alert set value, the system is put in an alert status. The setting range is the same as the input range.

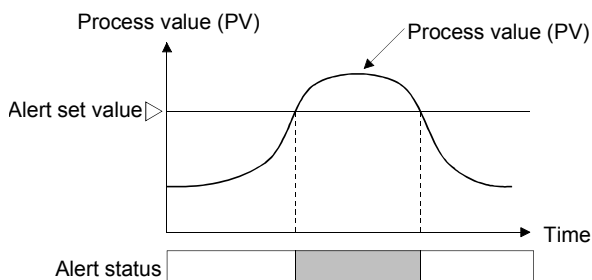

2) Lower limit input alert

When the process value (PV) is equal to or less than the alert set value, the system is put in an alert status. The setting range is the same as the input range.

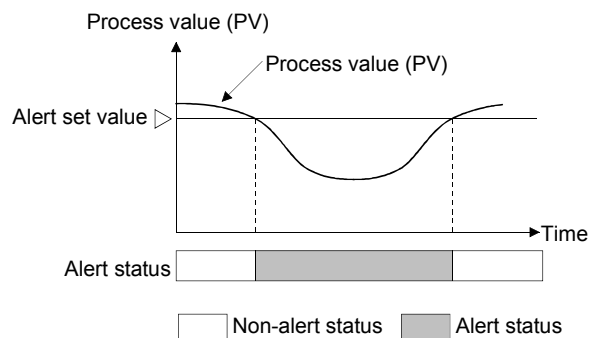

(b) Deviation alerts

1) Upper limit deviation alert

When the deviation [process value (PV) - set value (SV)] is equal to or greater than the alert set value, the system is put in an alert status.

The setting range is \pm full-scale.

[When alert set value is positive]

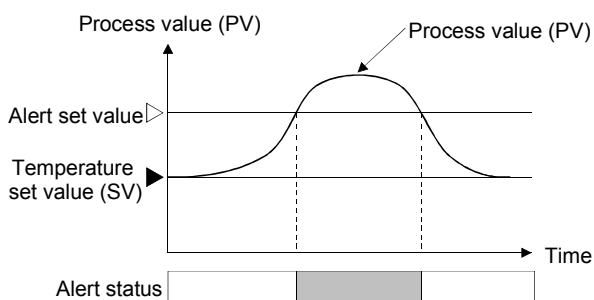

[When alert set value is negative]

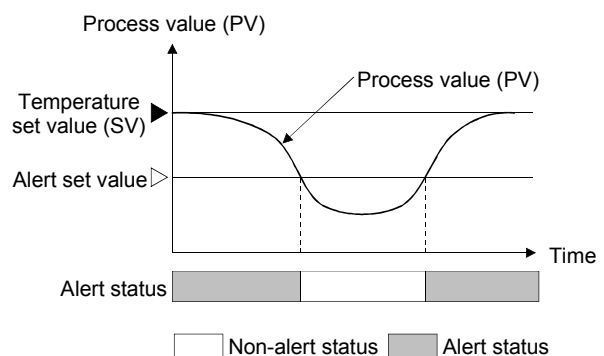

2) Lower limit deviation alert

When the deviation [process value (PV) - set value (SV)] is equal to or less than the alert set value, the system is put in an alert status.

The setting range is \pm full-scale.

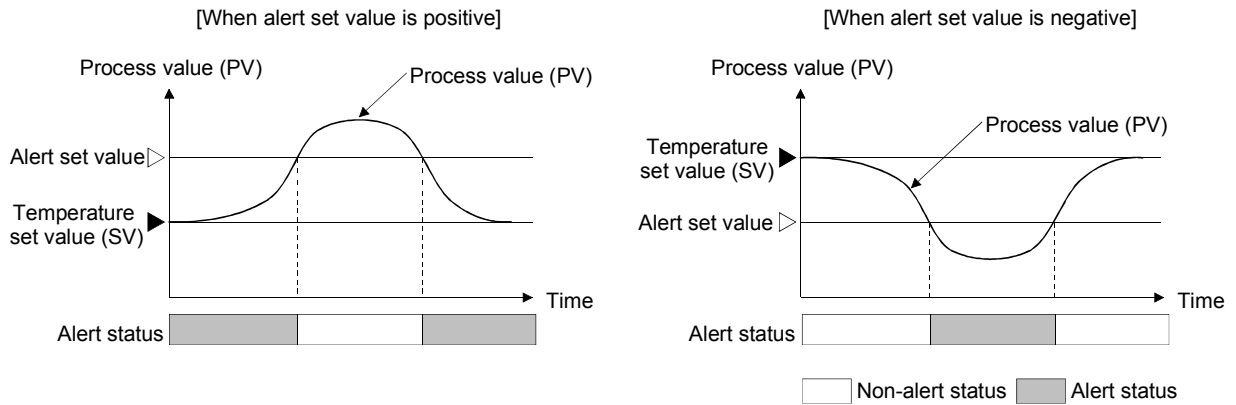

3) Upper/lower limit deviation alert

When the absolute value of deviation [process value (PV) - set value (SV)] is equal to or greater than the alert set value, the system is put in an alert status.

The setting range is 0 to + full-scale.

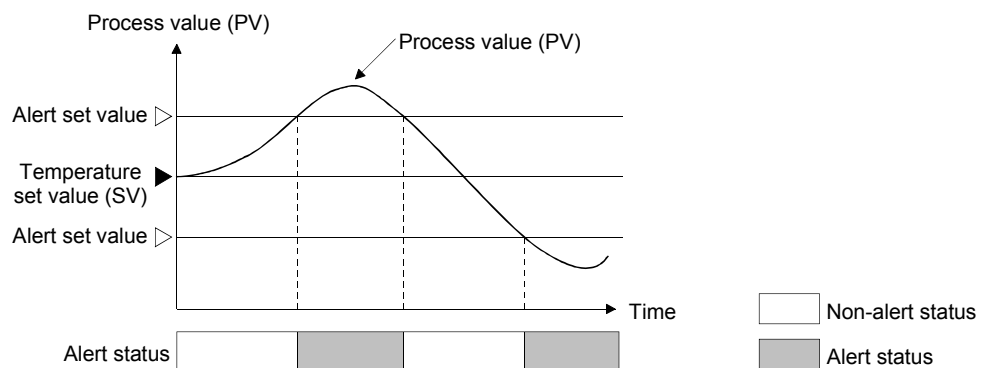

4) Within-range alert

When the absolute value of deviation [process value (PV) - set value (SV)] is equal to or less than the alert set value, the system is put in an alert status.

The setting range is 0 to + full-scale.

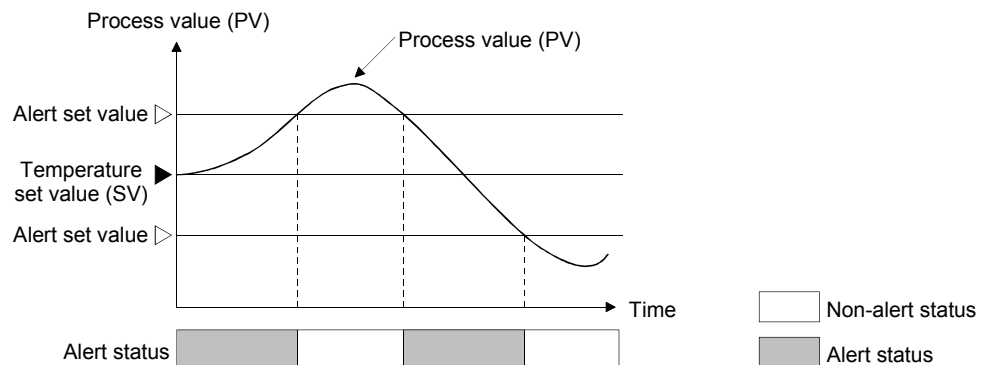

(2) The Q64TC allows the alerts function in (1) to be set with the addition of an alert dead band, alert delay count or wait/re-wait.

The following table indicates the alerts function which can be used with the addition of alert dead band, alert delay count and wait/re-wait.

Alerts function		Dead band setting	Alert delay count	Wait	Re-wait
Input alert	Upper limit alert	○	○	○	—
	Lower limit alert	○	○	○	—
Deviation alert	Upper limit deviation alert	○	○	○	○
	Lower limit deviation alert	○	○	○	○
	Upper/lower limit deviation alert	○	○	○	○
	Within-range alert	○	○	—	—

(a) Alert dead band setting

When the process value (PV)/deviation is close to the alert set value, the alert status may alternate with the non-alert status due to input instability or the like. Setting the alert dead band prevents the alert status and non-alert status from alternating with each other due to input instability or the like when the process value (PV)/deviation is near the alert set value.

Example: When the dead band value is set to the upper limit input alert, the system is placed in the alert status when the upper limit of the input rises to or above the alert set value. The system is put in the non-alert status when the upper limit falls below the alert dead band.

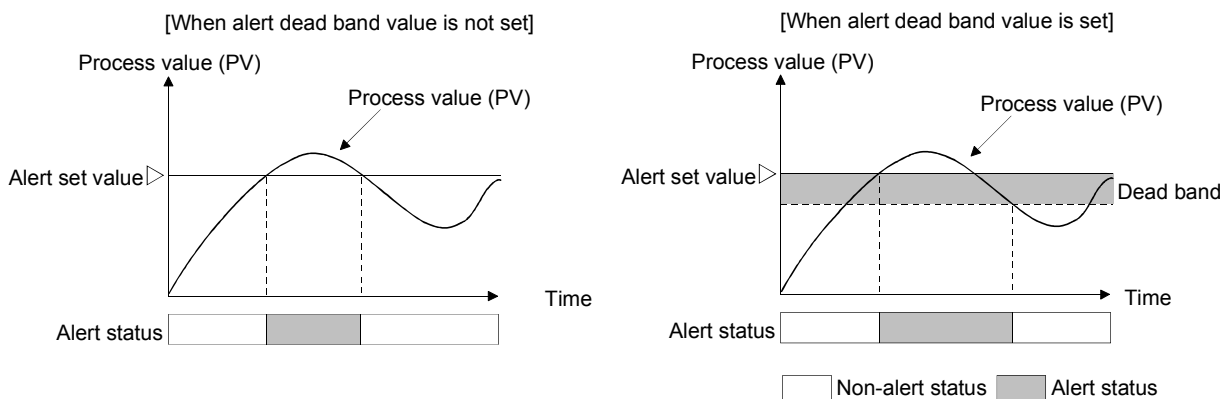

(b) Alert delay count setting

The system is set in the alert status when the process value (PV) that has reached the alert set value remains in the alert range until the sampling count becomes equal to or greater than the preset alert delay count.

Example: When the alert delay count set to the input upper limit alert is 5, the system is not placed in the alert status if the sampling count is 4 or less.

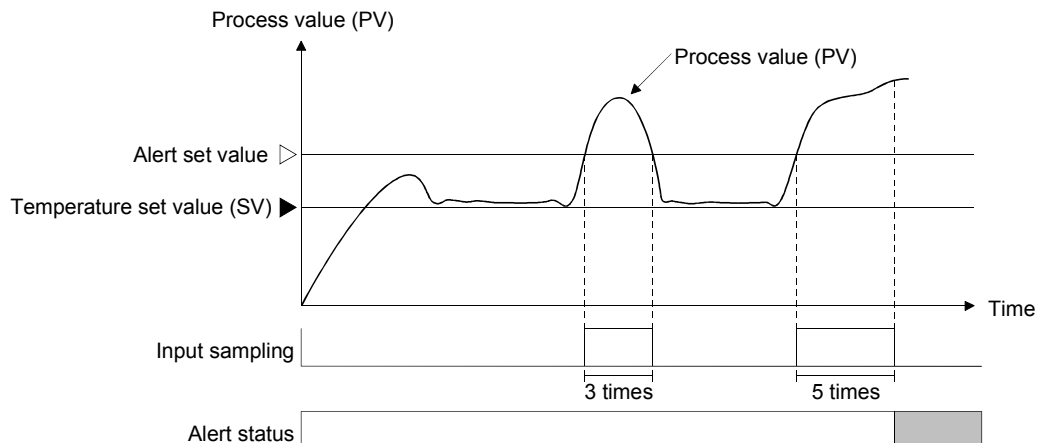

(c) Wait alert

Choosing the wait alert ignores the alert status if the process value (PV)/deviation is in that status when the setting mode is changed to the operation mode, and makes the alert function invalid until the process value comes out of the alert status once.

Example: Selecting the lower limit deviation alert with wait makes the alert function invalid until the process value exceeds the alert set value.

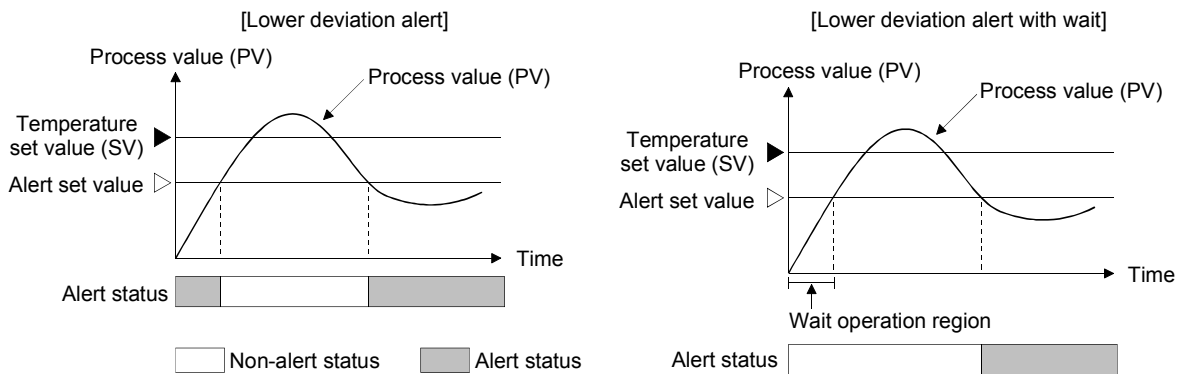

POINT

When the system has reached the non-alert status even once after an alert judgment start following the setting of the alert mode, the alert function with wait will be invalid if you choose the mode with wait.

(d) Re-wait alert

The re-wait alert is a wait alert-based feature which has the additional function to make the alert function invalid again when the set value (SV) is changed.

For set value changing control, choosing the re-wait alert avoids the alarm status reached when the set value is changed.

Example: If the process value (PV) is at the position as shown below before the setting is changed, changing the temperature set value (SV) for deviation alert will put the process value in the alert region and turn on the alert. To prevent this, the function makes the alert wait operation valid and the alert output to wait.

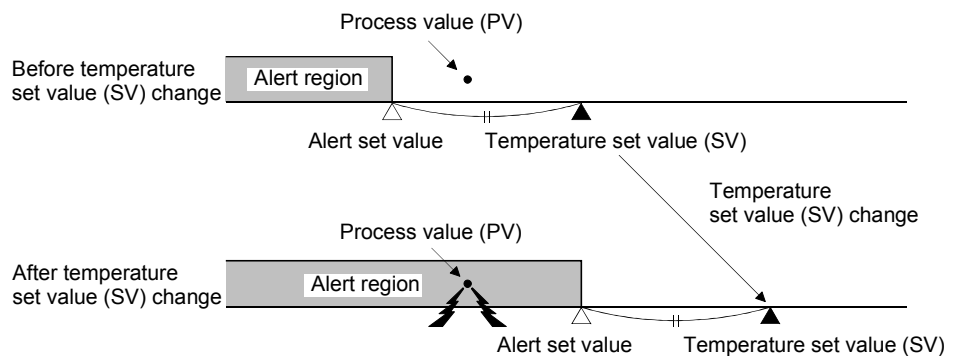

- (3) The Q64TC allows four different alerts (alert 1 to 4) to be selected and used from among the alerts, wait alert and re-wait alert.

Set the alerts mode used as alerts 1 to 4 at the following buffer memory addresses:

Mode setting item	CH1	CH2	CH3	CH4
Alert 1	C0H	D0H	E0H	F0H
Alert 2	C1H	D1H	E1H	F1H
Alert 3	C2H	D2H	E2H	F2H
Alert 4	C3H	D3H	E3H	F3H

- (4) Set the alert set value, alert dead band value and alert delay count at the following buffer memory addresses:

Channel No.	Buffer memory address		
	Alert set value	Alert dead band value	Alert delay count
1	26H to 29H	A4H	A5H
2	46H to 49H		
3	66H to 69H		
4	86H to 89H		

3.2.12 Control output setting at CPU stop error occurrence

- (1) You can set the Q64TC control output (HOLD/CLEAR) to be provided when the programmable controller CPU has generated a stop error.
- (2) To make this setting, use the intelligent function module switch setting on GX Developer.
- CLEAR : Stops the PID control, temperature judgement and alert judgement functions and turns off external outputs.
 - HOLD : Holds the control status prior to a programmable controller CPU stop. For example, when PID control was exercised before a programmable controller CPU stop, PID control is continued if the programmable controller CPU stops.

Refer to Section 4.5 for details of the setting method.

3.2.13 The settings and control status of the output signal and buffer memory controlling the Q64TC control status

The Q64TC has the output signals (Y), buffer memory and intelligent function module switch which set its control status.

The control status of the Q64TC is governed as indicated below by the settings of the output signals, buffer memory and intelligent function module switch.

(1) Intelligent function module switch setting

Output setting for CPU stop error (refer to Section 4.5)	Control status		
	PID control	Temperature judgment	Alert judgment
Intelligent function module switch			
If a CPU stop error occurs at the setting of "CLEAR"	—	—	—
Other than above	In accordance with control status of other setting items		

○: Executed, —: Not executed

(2) Unused channel setting

Unused channel setting (refer to Section 3.5.33)	Control status		
	PID control	Temperature judgment	Alert judgment
3DH, 5DH, 7DH, 9DH			
Unused	—	—	—
Used	In accordance with control status of other setting items		

○: Executed, —: Not executed

(3) Other settings

Operation mode command (refer to Section 3.4) *1	PID continuation flag (refer to Section 3.5.41)	Forced PID control stop command (refer to Section 3.4.3)	Stop mode setting (refer to Section 3.5.13)	Control status		
				PID control	Temperature judgment	Alert judgment
Yn1	A9H	YnC to YnF	21H, 41H, 61H, 81H			
1) Setting mode (at power-on)	Stop/continue	OFF/ON	Stop	—	—	—
			Monitor	—	○	—
			Alert	—	○	○
2) Operation mode (during operation)	Stop/continue	ON	Stop/monitor/alert	○	○	○
			Stop	—	—	—
			Monitor	—	○	—
3) Setting mode (after operation)	Stop	OFF/ON	Stop	—	—	—
			Monitor	—	○	—
			Alert	—	○	○
	Continue	ON	Stop/monitor/alert	○	○	○
			Stop	—	—	—
			Monitor	—	○	—
			Alert	—	○	○

○: Executed, —: Not executed

*1: The settings of the operation mode command will be explained in the following three different modes.

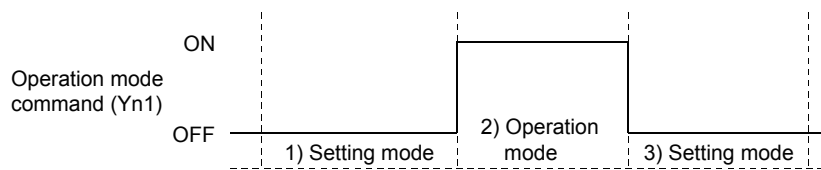

3.3 Sampling Period and Control Output Period

(1) Sampling period

(a) The Q64TC performs PID operations in order of CH1, CH2, CH3, CH4, CH1, CH2

The time from when PID operation is started on the current channel (CHn) until PID operation is restarted on the current channel (CHn) is called a sampling period.

(b) The sampling period is 0.5 seconds regardless of the number of channels used.

Since other processings (such as error check) are also performed on unused channels, the sampling period will not change if you make unused channel setting.

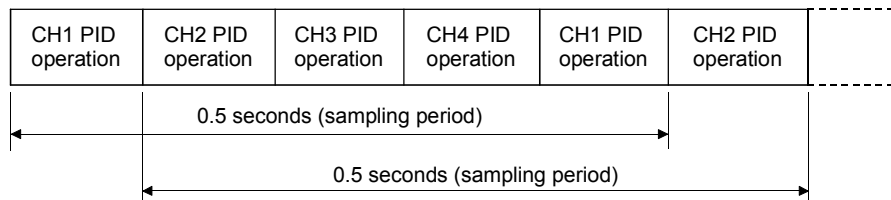

(2) Control output period

(a) The control output period indicates the ON/OFF cycle of transistor output.

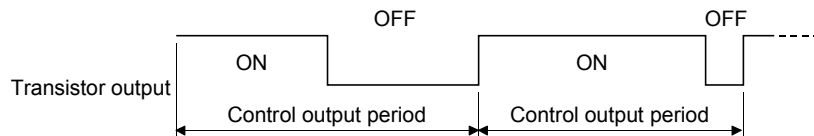

The manipulated value (MV) represents the ON time of this control output period as a percentage. (Refer to Section 3.5.6)

(b) Set the control output period to Control output period setting (buffer memory address: 2FH, 4FH, 6FH, 8FH) in the range 1 to 100s.

3.4 I/O Signals Transferred to/from the Programmable Controller CPU

This section explains the allocation and applications of the Q64TC I/O signals.

3.4.1 I/O signal list

- (1) The Q64TC uses 16 input points and 16 output points to transfer signals to/from the programmable controller CPU.
- (2) Table 3.4 lists the I/O signals used by the Q64TC.
Inputs (X) mean the signals from the Q64TC to the programmable controller CPU and outputs (Y) the signals from the programmable controller CPU to the Q64TC.
- (3) The I/O signals (X, Y) indicated in this manual assume that the module is loaded on the I/O slot 0 of the main base unit.
If the Q64TC is mounted on other than the I/O slot 0, change the I/O signals for those of the slot where the module is mounted.
- (4) When the Q64TCTTBW or Q64TCRTBW is used, the device numbers of the I/O signals increase by 16 points depending on how many free points the left-hand side slots have.
Hence, as I/O signals are given as indicated below in this manual, read them according to the module used.

Example) When a signal is given as Yn1

When the Q64TCTT or Q64TCRT is used: Y1

When the Q64TCTTBW or Q64TCRTBW is used: Y11

Table 3.4 I/O signal list

Input signal (Signal direction: Q64TC → programmable controller CPU)		Output signal (Signal direction: Q64TC ← programmable controller CPU)	
Device No.	Signal name	Device No.	Signal name
Xn0	Module ready flag	Yn0	Reserved
Xn1	Operation mode status	Yn1	Operation mode command
Xn2	Write error flag	Yn2	Error reset command
Xn3	Hardware error flag	Yn3	Reserved
Xn4	CH1 Auto tuning status	Yn4	CH1 Auto tuning start command
Xn5	CH2 Auto tuning status	Yn5	CH2 Auto tuning start command
Xn6	CH3 Auto tuning status	Yn6	CH3 Auto tuning start command
Xn7	CH4 Auto tuning status	Yn7	CH4 Auto tuning start command
Xn8	E ² PROM write completion flag	Yn8	E ² PROM backup start command
Xn9	Default value write completion flag	Yn9	Default setting registration command
XnA	E ² PROM write failure flag	YnA	Reserved
XnB	Setting change completion flag	YnB	Setting change command
XnC	CH1 Alert flag	YnC	CH1 Forced PID control stop command
XnD	CH2 Alert flag	YnD	CH2 Forced PID control stop command
XnE	CH3 Alert flag	YnE	CH3 Forced PID control stop command
XnF	CH4 Alert flag	YnF	CH4 Forced PID control stop command

POINT

We cannot guarantee the functions of the Q64TC if any of the reserved areas is turned on/off in a sequence program.

3.4.2 Input signal functions

(1) Module ready flag (Xn0)

(a) This signal turns on as soon as the Q64TC is ready when the programmable controller CPU is powered on or reset.

(b) Read/write of the Q64TC buffer memory data from the programmable controller CPU is performed when the temperature control module ready flag is on.

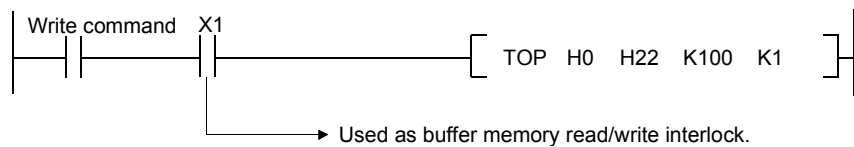

(c) This signal turns off on detection of a watchdog timer error. The Q64TC stops temperature control operation and turns off the output.

(2) Operation mode status (Xn1)

This signal turns on in the operation mode and turns off in the setting mode. Do not change the set value during mode shift processing.

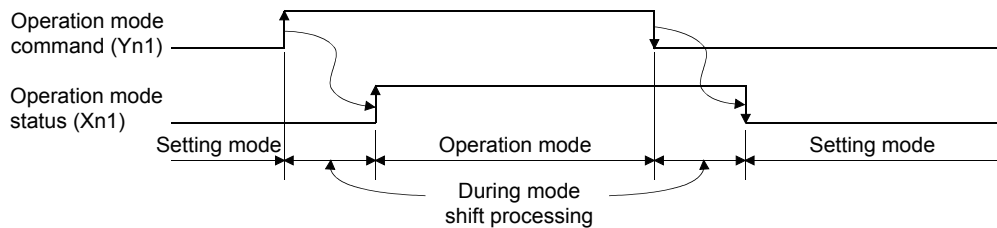

(3) Write error flag (Xn2)

This signal turns on at write error occurrence.

A write error occurs under any of the following conditions.

- When data is set to the reserved area.
- When a setting change made to the area write-enabled in the setting mode only is made in the operation mode.
- When data outside the setting range is set.
- When data setting is changed during default setting registration.

(4) Hardware error flag (Xn3)

This signal turns on when the temperature control module results in a hardware error.

(5) Auto tuning status (Xn4 to Xn7)

(a) This signal turns on when auto tuning of the corresponding channel is executed.

Channel	Auto tuning status	ON/OFF status
1	Xn4	ON : Auto tuning in execution OFF: Auto tuning not in execution or completed
2	Xn5	
3	Xn6	
4	Xn7	

(b) Auto tuning is executed using Auto tuning command (Yn4 to Yn7).

(c) This signal turns "on" while auto tuning is being executed and turns "off" automatically on completion of auto tuning.

(6) E²PROM write completion flag (Xn8)

(a) This signal turns on after completion of write of buffer memory contents to E²PROM which starts when E²PROM backup start command (Yn8) turns on.

(b) When the E²PROM backup start command turns off, the E²PROM write completion flag also turns off.

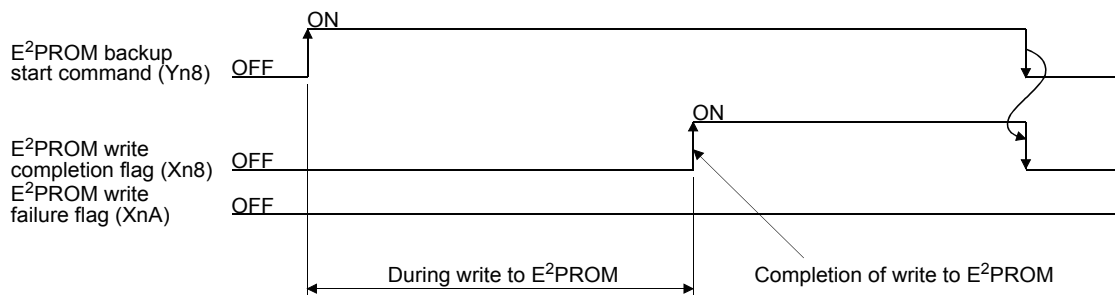

(7) Default value write completion flag (Xn9)

(a) Turns on after completion of write of the Q64TC default values to buffer memory which starts when Default setting registration start command (Yn9) turns on.

(b) When Default setting registration start command (Yn9) turns off, Default value write completion flag (Xn9) also turns off.

(c) Perform unused channel setting to unused channels after completion of default value write.

If unused channel setting is not made to unused channels, the "ALM" LED of the Q64TC is lit.

(8) E²PROM write failure flag (XnA)

(a) This signal turns on at a failure of write of buffer memory contents to E²PROM which starts when E²PROM backup start command (Yn8) turns on.

- OFF : Completion of write to E²PROM
- ON : Failure of write to E²PROM (Write could not be completed normally)

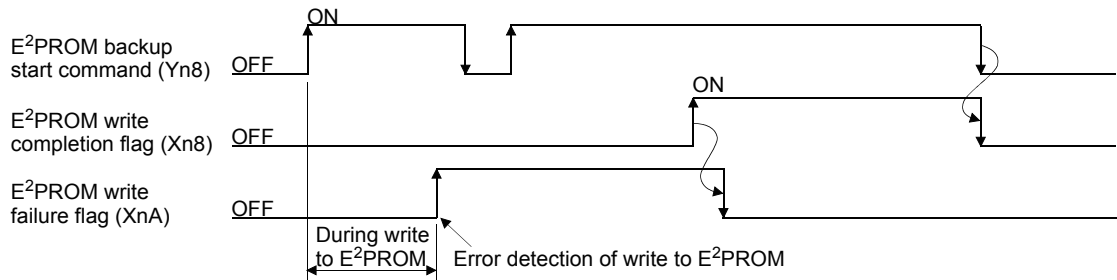

(b) E²PROM write failure flag (XnA) turns off at normal completion of write to E²PROM.

(c) When E²PROM write failure flag (XnA) has turned on, the E²PROM contents are undefined.

Hence, powering on the programmable controller CPU again or resetting it with the E²PROM write failure flag on will make the buffer memory contents undefined, causing the Q64TC to operate with the default values.

(9) Setting change completion flag (XnB)

(a) This signal turns on after completion of reflection of buffer memory settings on control which starts when Setting change command (YnB) turns on.

(b) When Setting change command (YnB) turns off, Setting change completion flag (YnB) also turns off.

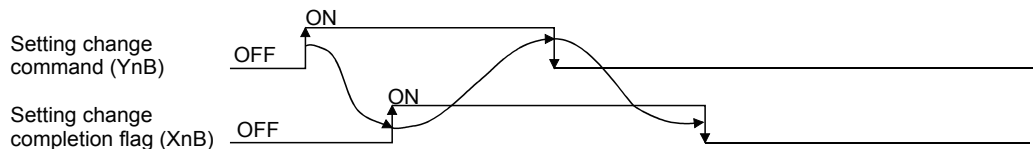

(10) Alert occurrence flag (XnC to XnF)

(a) This signal turns on at alarm occurrence on the corresponding channel.

Channel	Alert occurrence flag	ON/OFF status	Alert definition (buffer memory address)
1	XnC	OFF: Without alarm occurrence	5H
2	XnD		6H
3	XnE	ON : With alarm occurrence	7H
4	XnF		8H

(b) When an alert occurs, the alert definition is stored into Alert definition (buffer memory address: 5H to 8H) and the alert occurrence flag turns on.

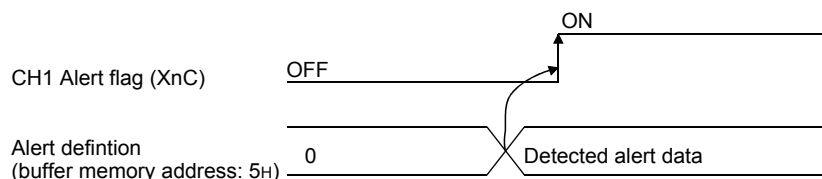

3.4.3 Output signal functions

(1) Operation mode command (Yn1)

(a) This signal is used to set the operation mode of the temperature control function.

- OFF : Setting mode
- ON : Operation mode

(b) This signal is set to all 4 channels together.

(c) The following setting items may be changed only when Yn1 is off.

- Input range (buffer memory address: 20H, 40H, 60H, 80H)
- Alert set value 1 to 4 (buffer memory address: 26H to 29H, 46H to 49H, 66H to 69H, 86H to 89H)

A write data error (error code: 3) will occur if any of these items is changed in the operation mode.

(d) Refer to Section 3.2.13 for the Q64TC operation governed by on/off of the Operation mode command (Yn1).

(2) Error reset command (Yn2)

This signal is used to turn off Write error flag (Xn2) and clear (reset) Write data error code (buffer memory address: 0H).

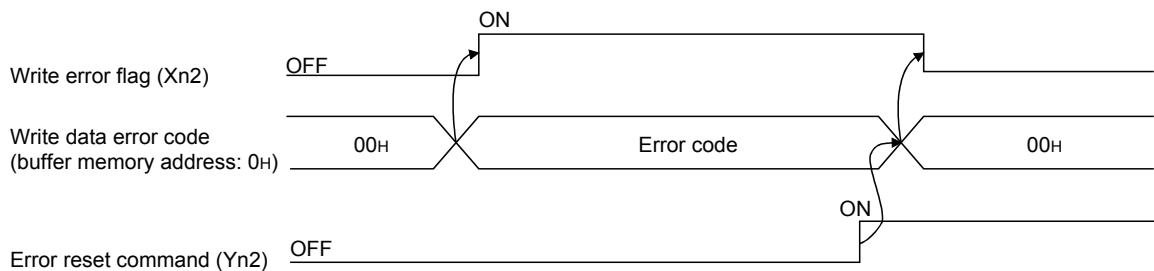

(3) Auto tuning command (Yn4 to Yn7)

(a) This signal is used to start auto tuning.

(b) Turning on Auto tuning command (Yn4 to Yn7) starts auto tuning and turns on Auto tuning status (Xn4 to Xn7).

When auto tuning is completed, Auto tuning status (Xn4 to Xn7) turns off.

(c) Keep Auto tuning command (Yn4 to Yn7) on while auto tuning is in execution, and turn it off on completion of auto tuning.

(d) Turning off Auto tuning command (Yn4 to Yn7) during auto tuning execution stops auto tuning.

When auto tuning is stopped, the PID constants in buffer memory do not change.

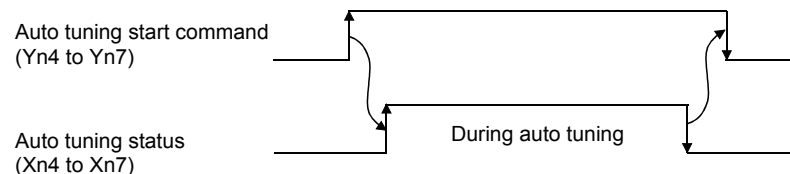

(e) Auto tuning is not performed when the set value of the proportional band (P) setting (buffer memory address: 23H, 43H, 63H, 83H) is 0.

(4) E²PROM backup start command (Yn8)

(a) This signal is used to write buffer memory contents to E²PROM.

(b) Turning on E²PROM backup start command (Yn8) writes buffer memory contents to E²PROM.

1) "E²PROM write completion flag (Xn8)" turns on at normal completion of write.

2) If write to E²PROM is not completed normally, "E²PROM write failure flag (XnA)" turns on.

If XA has turned on, turn on the E²PROM backup start command again to write data to E²PROM.

POINT

The number of writes to E²PROM is up to 100,000 times.

When setting the PID constants, etc. at a programmable controller CPU startup, reduce the number of writes by avoiding write to E²PROM, for example.

(5) Default setting registration start command (Yn9)

(a) This signal is used to return buffer memory contents to default values.

Turning on Default setting registration start command (Yn9) writes the default values of the Q64TC to buffer memory and Default value write completion flag (Xn9) turns on at its completion.

(b) Make default setting when Operation mode status (Xn1) is off (setting mode).

You cannot make default setting when Operation mode status (Xn1) is on (operation mode).

(6) Setting change command (YnB)

(a) This signal is used to determine the following buffer memory contents as set values.

- Input range (buffer memory address: 20H, 40H, 60H, 80H)
- Alert 1 to 4 mode setting (buffer memory address: C0H to C3H, D0H to D3H, E0H to E3H, F0H to F3H)

(b) For the setting items indicated in (a), their set values are not reflected on the module operation if they are written to the corresponding buffer memory addresses. To determine them as set values, this device must be turned on after the values are written to buffer memory.

(c) Turning on Setting change command (YnB) starts the operation as set in the corresponding buffer memory address. Setting change completion flag (XnB) turns on at completion of the setting change.

For setting items other than the above, their set values are determined by merely writing values to the buffer memory.

(d) This device is usable as an interlock for Operation mode command (Yn1).

(7) Forced PID control stop command (YnC to YnF)

(a) This signal is used to stop the PID operation of the corresponding channel forcibly.

(b) The mode in which PID operation stops is governed by the setting of Stop mode setting (buffer memory address: 21H, 41H, 61H, 81H).

3.5 Buffer Memory

3.5.1 Buffer memory list

(1) Buffer memory common to the Q64TCs

Address (Hexadecimal (Decimal))				Settings	Range	Initial value	Read/ write *3	Reference section	
CH1	CH2	CH3	CH4						
0H (0)				Write data error code	—	—	R	Section 3.5.2	
1H (1)	2H (2)	3H (3)	4H (4)	Decimal point position	Q64TCTT(BW)	—	0	R	Section 3.5.3
					Q64TCRT(BW)	—	1		
5H (5)	6H (6)	7H (7)	8H (8)	Alert definition	—	—	R	Section 3.5.4	
9H (9)	AH (10)	BH (11)	CH (12)	Temperature process value (PV)	—	—	R	Section 3.5.5	
DH (13)	EH (14)	FH (15)	10H (16)	Manipulated value (MV)	—	—	R	Section 3.5.6	
11H (17)	12H (18)	13H (19)	14H (20)	Temperature rise judgment flag	—	—	R	Section 3.5.7	
15H (21)	16H (22)	17H (23)	18H (24)	Transistor output flag	—	—	R	Section 3.5.8	
19H (25)	1AH (26)	1BH (27)	1CH (28)	Reserved	—	—	—	—	
1DH (29)				Q64TCTT(BW)	Cold junction temperature process value	—	—	R	Section 3.5.9
				Q64TCRT(BW)			Reserved	—	
1EH (30)				MAN mode shift completion flag	—	—	R	Section 3.5.10	
1FH (31)				E ² PROM's PID constant read/write completion flag	—	—	R	Section 3.5.11	
20H (32)	40H (64)	60H (96)	80H (128)	Input range *1	Q64TCTT(BW)	Refer to Section 3.5.12.	2	R/W	Section 3.5.12
					Q64TCRT(BW)		7		
21H (33)	41H (65)	61H (97)	81H (129)	Stop mode setting	0: Stop, 1: Monitor, 2: Warning	1	R/W	Section 3.5.13	
22H (34)	42H (66)	62H (98)	82H (130)	Set value (SV) setting	In accordance with input range setting	0	R/W	Section 3.5.14	
23H (35)	43H (67)	63H (99)	83H (131)	Proportional band (P) setting	0 to 10000(0.0 to 1000.0%)	30	R/W	Section 3.5.15	
24H (36)	44H (68)	64H (100)	84H (132)	Integral time (I) setting	1 to 3600(s)	240	R/W		
25H (37)	45H (69)	65H (101)	85H (133)	Derivative time (D) setting	0 to 3600(s)	60	R/W		
26H (38)	46H (70)	66H (102)	86H (134)	Alert set value 1	In accordance with alert mode setting and input range setting	0	R/W	Section 3.5.16	
27H (39)	47H (71)	67H (103)	87H (135)	Alert set value 2					
28H (40)	48H (72)	68H (104)	88H (136)	Alert set value 3					
29H (41)	49H (73)	69H (105)	89H (137)	Alert set value 4					
2AH (42)	4AH (74)	6AH (106)	8AH (138)	Upper output limiter	-50 to 1050(-5.0 to 105.0%)	1000	R/W	Section 3.5.17	
2BH (43)	4BH (75)	6BH (107)	8BH (139)	Lower output limiter		0	R/W		
2CH (44)	4CH (76)	6CH (108)	8CH (140)	Output variation limiter	0 to 1000(0.0 to 100.0%/s)	0	R/W	Section 3.5.18	

*1: This setting may be changed only in the setting mode. Note that changing it in the operation mode will result in a write data error (error code: 3). Also, Setting change command (YnB) must be turned on to change the setting.

*2: Available only for the Q64TCTTBW and Q64TCRTBW.

*3: Indicates whether reading from and writing to a sequence program are enabled.

R : Reading enabled

W : Writing enabled

Address (Hexadecimal (Decimal))				Settings	Range	Initial value	Read/ write *3	Reference section	
CH1	CH2	CH3	CH4						
2D _H (45)	4D _H (77)	6D _H (109)	8D _H (141)	Sensor compensation value setting	-5000 to 5000 (-50.00 to 50.00%)	0	R/W	Section 3.5.19	
2E _H (46)	4E _H (78)	6E _H (110)	8E _H (142)	Adjustment sensitivity (dead band) setting	1 to 100(0.1 to 10.0%)	5	R/W	Section 3.5.20	
2F _H (47)	4F _H (79)	6F _H (111)	8F _H (143)	Control output period setting	1 to 100(s)	30	R/W	Section 3.5.21	
30 _H (48)	50 _H (80)	70 _H (112)	90 _H (144)	Primary delay digital filter setting	0 to 100(s)	0	R/W	Section 3.5.22	
31 _H (49)	51 _H (81)	71 _H (113)	91 _H (145)	Control response parameter	0: Slow, 1: Normal, 2: Fast	0	R/W	Section 3.5.23	
32 _H (50)	52 _H (82)	72 _H (114)	92 _H (146)	AUTO/MAN mode switching	0: Auto (AUTO), 1: Manual (MAN)	0	R/W	Section 3.5.24	
33 _H (51)	53 _H (83)	73 _H (115)	93 _H (147)	MAN output setting	-50 to 1050 (-5.0% to 105.0%)	0	R/W	Section 3.5.25	
34 _H (52)	54 _H (84)	74 _H (116)	94 _H (148)	Setting change rate limiter	0 to 1000 (0.0 to 100.0%/min)	0	R/W	Section 3.5.26	
35 _H (53)	55 _H (85)	75 _H (117)	95 _H (149)	AT bias	±input range width	0	R/W	Section 3.5.27	
36 _H (54)	56 _H (86)	76 _H (118)	96 _H (150)	Forward/reverse action setting	0: Forward action, 1: Reverse action	1	R/W	Section 3.5.28	
37 _H (55)	57 _H (87)	77 _H (119)	97 _H (151)	Upper setting limiter	Q64TCTT(BW) Q64TCRT(BW)	Within measurement range	1300 6000	R/W	Section 3.5.29
				Lower setting limiter	Q64TCTT(BW) Q64TCRT(BW)				
38 _H (56)	58 _H (88)	78 _H (120)	98 _H (152)	Reserved	—	0	R/W	—	
39 _H (57)	59 _H (89)	79 _H (121)	99 _H (153)	Reserved	—	—	—	—	
3A _H (58)	5A _H (90)	7A _H (122)	9A _H (154)	Heater disconnection alert setting *2	0 to 100%	0	R/W	Section 3.5.30	
3B _H (59)	5B _H (91)	7B _H (123)	9B _H (155)	Loop disconnection detection judgment time	0 to 7200s	480	R/W	Section 3.5.31	
3C _H (60)	5C _H (92)	7C _H (124)	9C _H (156)	Loop disconnection detection dead band	Input range width	0	R/W	Section 3.5.32	
3D _H (61)	5D _H (93)	7D _H (125)	9D _H (157)	Unused channel setting	0: Used, 1: Unused	0	R/W	Section 3.5.33	
3E _H (62)	5E _H (94)	7E _H (126)	9E _H (158)	E ² PROM's PID constant read command	0: Without command, 1: With command	0	R/W	Section 3.5.34	
3F _H (63)	5F _H (95)	7F _H (127)	9F _H (159)	Automatic backup setting after auto tuning of PID constants	0: OFF, 1: ON	0	R/W	Section 3.5.35	
A0 _H (160)				Reserved	—	—	—	—	
A1 _H (161)				Reserved					
A2 _H (162)				Reserved					
A3 _H (163)				Reserved					
A4 _H (164)				Alert dead band setting	0 to 100(0.0 to 10.0%)	5	R/W	Section 3.5.36	
A5 _H (165)				Alert delay count	0 to 255 (times)	0	R/W	Section 3.5.37	
A6 _H (166)				Heater disconnection/output off- time current error detection delay count *2	3 to 255 (times)	3	R/W	Section 3.5.38	
A7 _H (167)				Temperature rise completion range setting	1 to 10 (°C)	1	R/W	Section 3.5.39	
A8 _H (168)				Temperature rise completion soak time setting	0 to 3600 (min)	0	R/W	Section 3.5.40	
A9 _H (169)				PID continuation flag	0: Stop, 1: Continue	0	R/W	Section 3.5.41	
AA _H (170)				Heater disconnection compensation function selection *2	0: OFF, 1: ON	0	R/W	Section 3.5.42	

*1: This setting may be changed only in the setting mode. Note that changing it in the operation mode will result in a write data error (error code: 3). Also, Setting change command (YnB) must be turned on to change the setting.

*2: Available only for the Q64TCTTBW and Q64TCRTBW.

*3: Indicates whether reading from and writing to a sequence program are enabled.

R : Reading enabled

W : Writing enabled

Address (Hexadecimal (Decimal))				Settings	Range	Initial value	Read/ write *3	Reference section
CH1	CH2	CH3	CH4					
AB _H (171)	AC _H (172)	AD _H (173)	AE _H (174)	Reserved	—	—	—	—
AF _H (175)				Transistor output monitor ON delay time setting	0 to 50(0 to 500ms)	0	R/W	Section 3.5.43
B0 _H (176)				CT monitor method switching *2	0: ON/OFF current, 1: ON current	0	R/W	Section 3.5.44
B1 _H (177)	B2 _H (178)	B3 _H (179)	B4 _H (180)	Manipulated value (MV)	0 to 4000, 0 to 12000, 0 to 16000	—	R	Section 3.5.45
B5 _H (181)				Manipulated value resolution switching	0: 0 to 4000, 1: 0 to 12000, 3: 0 to 16000	0	R/W	Section 3.5.46
B8 _H (184)	B9 _H (185)	BA _H (186)	BB _H (187)	Auto tuning mode selection	0: Standard mode 1: Fast response mode	0	R/W	Section 3.5.47
C0 _H (192)	D0 _H (208)	E0 _H (224)	F0 _H (240)	Alert 1 mode setting *1	0 to 14	0	R/W	Section 3.5.48
C1 _H (193)	D1 _H (209)	E1 _H (225)	F1 _H (241)	Alert 2 mode setting *1				
C2 _H (194)	D2 _H (210)	E2 _H (226)	F2 _H (242)	Alert 3 mode setting *1				
C3 _H (195)	D3 _H (211)	E3 _H (227)	F3 _H (243)	Alert 4 mode setting *1				

*1: This setting may be changed only in the setting mode. Note that changing it in the operation mode will result in a write data error (error code: 3). Also, Setting change command (YnB) must be turned on to change the setting.

*2: Available only for the Q64TCTTBW and Q64TCRTBW.

*3: Indicates whether reading from and writing to a sequence program are enabled.

R : Reading enabled

W : Writing enabled

(2) The Q64TCTTBW, Q64TCRTBW-dedicated buffer memory

Address (Hexadecimal (Decimal))								Settings	Range	Initial value	Read/write * 1	Reference section
CT1	CT2	CT3	CT4	CT5	CT6	CT7	CT8					
100H (256)	101H (257)	102H (258)	103H (259)	104H (260)	105H (261)	106H (262)	107H (263)	Heater current process value	—	—	R	Section 3.5.49
108H (264)	109H (265)	10AH (266)	10BH (267)	10CH (268)	10DH (269)	10EH (270)	10FH (271)	CT input channel assignment setting	0:Unused, 1:CH1, 2:CH2,3:CH3,4:CH4	0	R/W	Section 3.5.50
110H (272)	111H (273)	112H (274)	113H (275)	114H (276)	115H (277)	116H (278)	117H (279)	CT selection	0: 0 to 1000 (0.0 to 100.0(A)) 1: 0 to 2000 (0.00 to 20.00(A))	0	R/W	Section 3.5.51
118H (280)	119H (281)	11AH (282)	11BH (283)	11CH (284)	11DH (285)	11EH (286)	11FH (287)	Reference heater current value	Heater current range (×0.1A / ×0.01A)	0	R/W	Section 3.5.52

* 1 : Indicates whether reading from and writing to a sequence program are enabled.

R : Reading enabled

W : Writing enabled

3.5.2 Write data error code (buffer memory address: 0H)

Stores the error code and buffer memory address of the error detected when write from programmable controller CPU to the Q64TC buffer memory was performed.

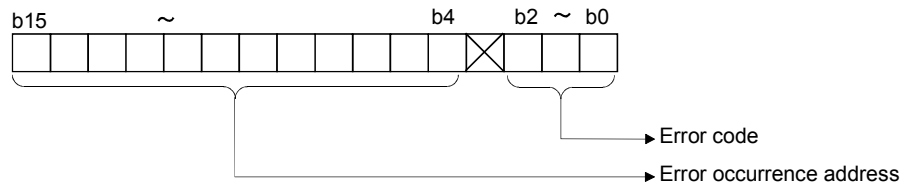

- (1) When data is written from the programmable controller CPU, the Q64TC checks:
 - Whether write destination is read-only area or not
 - Whether write destination is reserved area or not
 - Whether write data range is proper or not
- (2) The following processings are performed at write error occurrence.
 - Error code is stored (refer to Section 8.1 for error code details).
 - Write error flag (Xn2) turns on.
- (3) If more than one error has occurred, the error code and error occurrence address of the error having the highest priority are stored. (Refer to Section 8.2 for details of processing at error occurrence.)
- (4) Refer to Section 8.1 for error resetting.

3.5.3 Decimal point position (buffer memory address: 1H to 4H)

- (1) The decimal point position for the following data is stored according to Input range (buffer memory address: 20H, 40H, 60H, 80H) which determines the measured temperature range.
- Temperature process value (PV) (buffer memory address: 9H to CH)
 - Set value (SV) setting (buffer memory address: 22H, 42H, 62H, 82H)
 - Alert set value 1 to 4 (buffer memory address: 26H to 29H, 46H to 49H, 66H to 69H, 86H to 89H)
 - AT bias (buffer memory address: 35H, 55H, 75H, 95H)
 - Upper setting limiter (buffer memory address: 37H, 57H, 77H, 97H)
 - Lower setting limiter (buffer memory address: 38H, 58H, 78H, 98H)
 - Loop disconnection detection dead band (buffer memory address: 3CH, 5CH, 7CH, 9CH)
- (2) "1" is stored if Input range (buffer memory address: 20H, 40H, 60H, 80H) of the setting increments (0.1) with a decimal point is set.
"0" is stored if Input range (buffer memory address: 20H, 40H, 60H, 80H) of the setting increments (1) without a decimal point is set.
- (3) Refer to the following table when performing write/read of the above data from the programmable controller CPU.

Decimal point position	For read	For write
0	Buffer memory data is read as is and used in sequence programs, etc.	The specified value is written as is.
1	One/tenth of the value read from a sequence program or the like is used as the actual value.	The value 10 times the specified value is written.

3.5.4 Alert definition (buffer memory address: 5H to 8H)

- (1) The bit associated with the alert detected on the corresponding channel turns to "1".

Associated bit number	Alert definition
b0	PV rose above the temperature measurement range*1 of the preset input range.
b1	PV fell below the temperature measurement range*1 of the preset input range.
b2 to b7	Unused
b8	Alert 1 turned on.
b9	Alert 2 turned on.
b10	Alert 3 turned on.
b11	Alert 4 turned on.
b12	Heater disconnection was detected.
b13	Loop disconnection was detected.
b14	Output off-time current error was detected.
b15	Unused

*1 : The temperature measurement range represents the range from the lower limit of -5% to the upper limit of +5% relative to the full-scale of the input range.

Example) Input range 38

Input range : -200.0 to 400.0

Temperature measurement range: -230.0 to 430.0

(An alert occurs at the temperature of lower than -230.0°C or higher than 430.0°C.)

3.5.5 Temperature process value (PV) (buffer memory address: 9H to CH)

- (1) Stores the Q64TC-detected value on which the following processings have been performed:
- Linearization
 - Sensor compensation
- (2) The stored value varies with the setting increments of Input range (buffer memory address: 20H, 40H, 60H, 80H) (refer to Section 3.5.12) as indicated below:
- If the setting increments(1) without a decimal point is set, the value is stored in increments of 1 degree Celsius.
 - If the setting increments(0.1) with a decimal point is set, the value is stored in increments of 0.1 degree Celsius. (The value is indicated without a decimal point.)

POINT
The following value is stored if the temperature detected by the temperature sensor falls outside the temperature measurement range:
• If the value is higher than the temperature measurement range: +5% of the (input range upper limit)
• If the value is lower than the temperature measurement range: -5% of the (input range lower limit)

3.5.6 Manipulated value (MV) (buffer memory address: D_H to 10_H)

- (1) Stores the result of PID operation performed on the basis of the temperature value imported from the temperature sensor.
- (2) The value stored is in the range -50 to 1050 (-5.0% to 105.0%).
However, the value is in the range 0% to 100% for external output.
 - Less than 0% : 0%
 - More than 100% : 100%
- (3) The manipulated value represents the ON time of Control output period setting (buffer memory address: 2F_H, 4F_H, 6F_H, 8F_H) as a percentage.
At the control output period of 30s (seconds) and the manipulated value of 600 (60.0%), the pulse turns on for 18 seconds and turns off for 12 seconds.

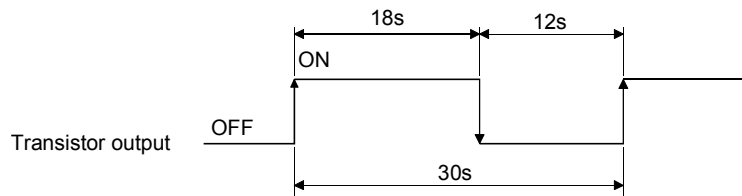

3.5.7 Temperature rise judgment flag (buffer memory address: 11_H to 14_H)

- (1) This flag checks whether the temperature process value (PV) is within the temperature rise completion range or not.
- (2) This flag turns to "1" when the temperature process value (PV) is within the temperature rise completion range.
Setting Temperature rise completion soak time setting (buffer memory address: A8_H) will cause this flag to turn to "1" when the temperature process value remains within the temperature rise completion range of the preset temperature rise completion soak time.

3.5.8 Transistor output flag (buffer memory address: 15_H to 18_H)

- (1) Stores the ON/OFF statuses of the transistor output and ON delay output.

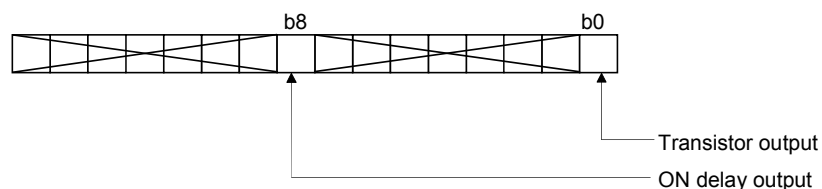

- (2) The following values are stored as the ON/OFF statuses of the transistor output and ON delay output.
 - ON : 1
 - OFF : 0

3.5.9 Q64TCTT(BW) Cold junction temperature process value (buffer memory address: 1DH)

- (1) Stores the measured temperature (0 to 55°C) of the cold junction temperature compensation resistor fitted to the Q64TCTT(BW).

3.5.10 MAN mode shift completion flag (buffer memory address: 1EH)

- (1) This flag checks whether switching from the automatic mode (AUTO) to the manual mode (MAN) has been completed or not.
The bit associated with the corresponding channel turns to "1" on completion of switching to the manual mode.
 - Channel 1: Bit 0 (b0)
 - Channel 2: Bit 1 (b1)
 - Channel 3: Bit 2 (b2)
 - Channel 4: Bit 3 (b3)
- (2) When setting the manipulated value (MV) in the manual mode, make setting after confirming that the manual mode shift completion flag has turned to "1".

3.5.11 E²PROM's PID constant read/write completion flag (buffer memory address: 1FH)

- (1) This flag indicates a normal completion or failure of the following functions.
 - E²PROM's PID constant read command
 - Automatic backup setting after auto tuning of PID constants

The following table indicates the definitions of the bits.

Bit number	Flag definition	Bit number	Flag definition
b0	Channel 1 read completion	b8	Channel 1 read failure
b1	Channel 2 read completion	b9	Channel 2 read failure
b2	Channel 3 read completion	b10	Channel 3 read failure
b3	Channel 4 read completion	b11	Channel 4 read failure
b4	Channel 1 write completion	b12	Channel 1 write failure
b5	Channel 2 write completion	b13	Channel 2 write failure
b6	Channel 3 write completion	b14	Channel 3 write failure
b7	Channel 4 write completion	b15	Channel 4 write failure

- (2) The following chart shows the ON/OFF timings of this flag relative to E²PROM's PID constant read command (buffer memory address: 3EH, 5EH, 7EH, 9EH). (For channel 1)

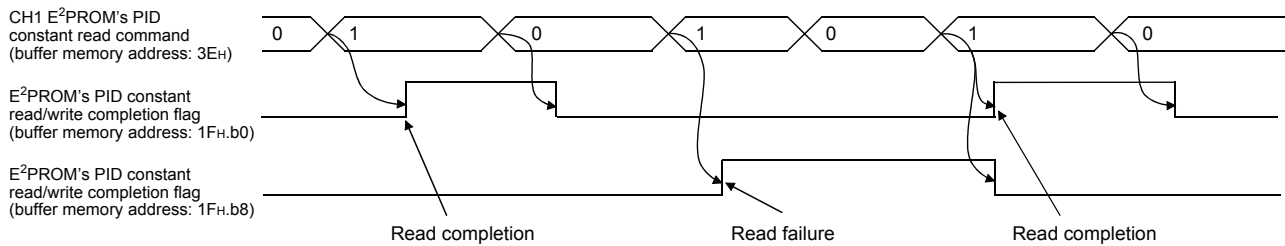

The read failure flag (b8 to b11) turns off on normal completion of read on the corresponding channel.

- (3) The following chart shows the ON/OFF timings of this flag relative to Automatic backup setting after auto tuning of PID constants (buffer memory address: 3FH, 5FH, 7FH, 9FH). (For channel 1)

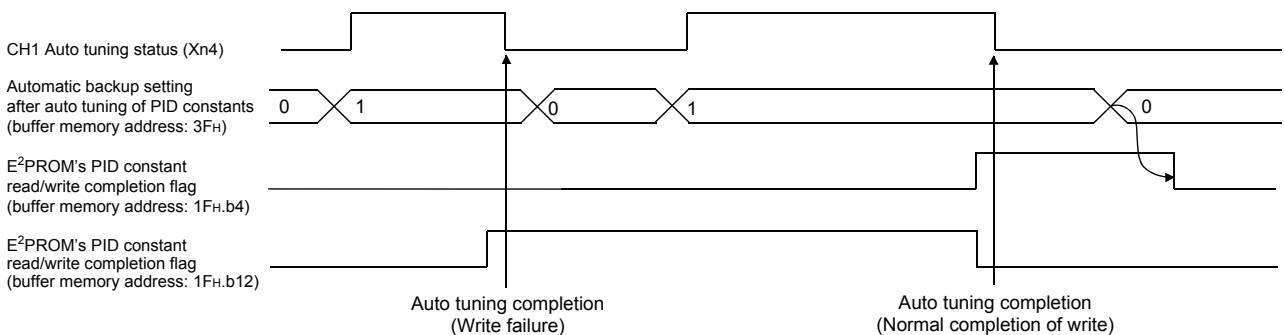

Browsing this flag on completion of auto tuning allows you to check whether automatic backup was completed normally or failed.

The write failure flag (b11 to b15) turns off on normal completion of write on the corresponding channel.

After checking the write flag, always set 0 (OFF) to Automatic backup setting after auto tuning of PID constants (buffer memory address: 3FH, 5FH, 7FH, 9FH).

If auto tuning is executed while 1 (ON) is set, even if internal processing of auto tuning is completed and PID constant is stored, Auto tuning status (Xn4 to Xn7) does not turn OFF and auto tuning is not completed.

3.5.12 Input range (buffer memory address: 20H, 40H, 60H, 80H)

- (1) The following table indicates the types and input range of the temperature sensors being connected to the Q64TC.

Set the input range value according to the temperature sensor and operating temperature range to be used.

Always set the input range when Operation mode status (Xn1) is off (setting mode).

(a) For use of the Q64TCTT(BW)

Thermocouple type	°C			°F		
	Measured temperature range	Input range	Setting increments	Measured temperature range	Input range	Setting increments
R	0 to 1700	1	1	0 to 3000	105	1
K	0 to 500	11	1	0 to 1000	100	1
	0 to 800	12	1	0 to 2400	101	1
	0 to 1300	2	1	0.0 to 1000.0	130	0.1
	-200.0 to 400.0	38	0.1	—	—	—
	0.0 to 400.0	36	0.1			
	0.0 to 500.0	40	0.1			
0.0 to 800.0	41	0.1				
J	0 to 500	13	1	0 to 1000	102	1
	0 to 800	14	1	0 to 1600	103	1
	0 to 1200	3	1	0 to 2100	104	1
	0.0 to 400.0	37	0.1	0.0 to 1000.0	131	0.1
	0.0 to 500.0	42	0.1	—	—	—
0.0 to 800.0	43	0.1				
T	-200 to 400	4	1	0 to 700	109	1
	-200 to 200	21	1	-300 to 400	110	1
	0 to 200	19	1	0.0 to 700.0	132	0.1
	0 to 400	20	1	—	—	—
	-200.0 to 400.0	39	0.1			
	0.0 to 400.0	45	0.1			
S	0 to 1700	15	1	0 to 3000	106	1
B	0 to 1800	16	1	0 to 3000	107	1
E	0 to 400	17	1	0 to 1800	108	1
	0 to 1000	18	1	—	—	—
	0.0 to 700.0	44	0.1			
N	0 to 1300	22	1	0 to 2300	111	1
U	0 to 400	25	1	0 to 700	114	1
	-200 to 200	26	1	-300 to 400	115	1
	0.0 to 600.0	46	0.1	—	—	—
L	0 to 400	27	1	0 to 800	116	1
	0 to 900	28	1	0 to 1600	117	1
	0.0 to 400.0	47	0.1	—	—	—
	0.0 to 900.0	48	0.1			
PL II	0 to 1200	23	1	0 to 2300	112	1
Wre5-26	0 to 2300	24	1	0 to 3000	113	1

(b) For use of the Q64TCRT(BW)

Platinum temperature-measuring resistor type	°C			°F		
	Measured temperature range	Input range	Setting increments	Measured temperature range	Input range	Setting increments
Pt100	-200.0 to 600.0	7	0.1	-300 to 1100	141	1
	-200.0 to 200.0	8	0.1	-300.0 to 300.0	143	0.1
JPt100	-200.0 to 500.0	5	0.1	-300 to 900	140	1
	-200.0 to 200.0	6	0.1	-300.0 to 300.0	142	0.1

(2) Relative to the stored value or set value of specific buffer memory, the setting increments is applied as indicated below.

Setting increments	Stored value	Set value
1	The value is stored in increments of 1 degree Celsius	The value is set in increments of 1 degree Celsius
0.1	The value indicated without a decimal point is stored in increments of 0.1 degree Celsius.	The value indicated without a decimal point is set in increments of 0.1 degree Celsius.

Example) To specify the temperature for the set value to 200.0 degree Celsius when the input range is set to 36 (setting increments: 0.1), set Set value (SV) setting (buffer memory address: 22H, 42H, 62H, 82H) to 2000.

For applicable buffer memory, refer to Decimal point position (buffer memory address: 1H to 4H) (Section 3.5.3)

(3) After the input range setting is changed, the temperature process value turns to "0" for about 8 seconds.

(4) When the input range is changed, the set value of the following setting items might shift to be outside the setting range, since the setting range shifts along with the input range change.

If this occurs, the setting item outside the setting range will detect a write data error (error code: 4).

To avoid this, before changing the input range, set the value of the setting item within the input range which has been changed.

- Set value (SV) setting (buffer memory address: 22H, 42H, 62H, 82H)
- Alert set value 1 to 4 (buffer memory address: 26H to 29H, 46H to 49H, 66H to 69H, 86H to 89H)
- AT bias (buffer memory address: 35H, 55H, 75H, 95H)
- Upper setting limiter (buffer memory address: 37H, 57H, 77H, 97H)
- Lower setting limiter (buffer memory address: 38H, 58H, 78H, 98H)
- Loop disconnection detection dead band (buffer memory address: 3CH, 5CH, 7CH, 9CH)

(5) To determine the set value change, you must turn on Setting change command (YnB).

3.5.13 Stop mode setting (buffer memory address: 21H, 41H, 61H, 81H)

- (1) Sets the mode to be entered at a PID operation stop.
The default value (initial value) is set to "monitor".
- (2) The setting values and operations of each mode are as shown below.

Setting mode	Set value	Operation		
		PID operation	Temperature judgment	Alert judgment
Stop	0	×	×	×
Monitor	1	×	○	×
Alert	2	×	○	○

○: Executed
×: Not executed

Operation is governed by the unused channel setting, setting/operation mode setting, PID continuation flag, forced stop command and CPU error stop-time control output setting. (Refer to Section 3.2.13.)

- (a) Temperature judgment: A temperature is input from the temperature sensor to check whether it is within the temperature measurement range of Input range (buffer memory address: 20H, 40H, 60H, 80H).
- (b) Alert judgment: Alert checks 1 to 4 in Section 3.5.4 are made.

POINT	<p>The default value (initial value) of the stop mode is set to "monitor". Hence, the channel without a temperature sensor connected results in a sensor input disconnection and the "ALM" LED is lit. For the channel to which a temperature sensor is not connected, set "1 (unused)" to Unused channel setting (buffer memory address: 3DH, 5DH, 7DH, 9DH).</p>
--------------	--

3.5.14 Set value (SV) setting (buffer memory address: 22H, 42H, 62H, 82H)

- (1) Sets the temperature for the set value of PID operation.
- (2) The setting range is within the temperature setting range specified Input range (buffer memory address: 20H, 40H, 60H, 80H) (refer to Section 3.5.12).
- (3) Setting a value outside the setting range will result in a write error (error code: 4) and Write error flag (Xn2) turns ON.
- (4) The set value varies with the setting increments of input range (buffer memory address: 20H, 40H, 60H, 80H)(refer to Section 3.5.12) as indicated below:
 - If the setting increments(1) without a decimal point is set, the value is set in increments of 1 degree Celsius.
 - If the setting increments(0.1) with a decimal point is set, the value is set in increments of 0.1 degree Celsius. (The value is indicated without a decimal point.)

3.5.15 PID constant setting

(buffer memory address: 23H to 25H, 43H to 45H, 63H to 65H, 83H to 85H)

- (1) Sets the proportional band (P), integral time (I) and derivative time (D) for performing PID operation.
- (2) As the proportional band (P), integral time (I) and derivative time (D), set values within the following ranges.

Item	Address (Hexadecimal)				Setting range	Constant for PID operation
	CH.1	CH.2	CH.3	CH.4		
Proportional band (P) setting	23H	43H	63H	83H	0 to 10000	0.0 to 1000.0%
Integral time (I) setting	24H	44H	64H	84H	1 to 3600	1 to 3600 s
Derivative time (D) setting	25H	45H	65H	85H	0 to 3600	0 to 3600 s

- (a) Set the proportional band (P) as a percentage (%) to the full scale of the set input range. For example, when the Q64TCRT is used, the input range 7 (-200.0 to 600.0°C) is selected, and the proportional band is 10.0%, the proportional band is set to 80.0°C.
 - (b) For two-position control *1, set the proportional band to "0".
 - (c) For PI control, set the derivative time to "0".
- (3) When executing auto tuning, do not set "0" to the proportional band. If its setting is "0", auto tuning will not be executed.
- *1: Two-position control keeps the temperature constant by switching the output ON and OFF recurrently following two values: 0% and 100% of the manipulation value relative to the set value (SV).

POINT

Proportional band (P) is the variation width of deviation (E), required to change the manipulation value (MV) from 0% to 100%.

With the proportional action, the relationship between the changes in the deviation (E) and manipulation value (MV) can be expressed in the following formula:

$$MV = K_p \cdot E \quad (K_p: \text{proportional gain})$$

From the formula above, the proportional band (P) is directed as shown below.

$$P = \frac{1}{K_p} \cdot 100$$

Widening the proportional band (P) leads to the reduction of the proportional gain (K_p). Thus, this reduces the changes in the manipulation value (MV) corresponding to the changes in the deviation (E).

Narrowing the proportional band (P) leads to the increase of the proportional gain (K_p). Thus, this increases the changes in manipulation value (MV) corresponding to the changes in the deviation (E).

[Proportional band in the reverse action]

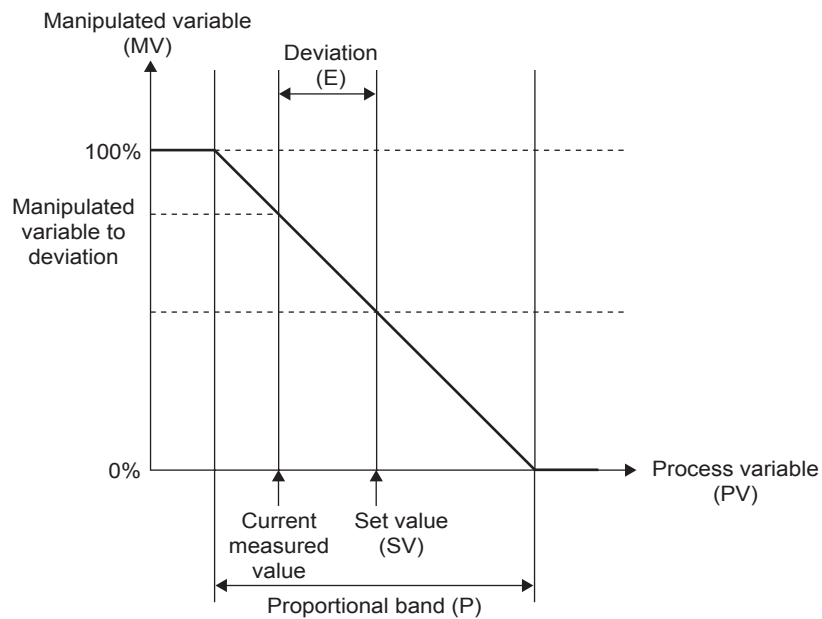

3.5.16 Alert set value 1 to 4

(buffer memory address: 26H to 29H, 46H to 49H, 66H to 69H, 86H to 89H)

- (1) Sets the temperature to turn on Alert 1 to 4 mode setting (buffer memory address: C0H to C3H, D0H to D3H, E0H to E3H, F0H to F3H)
- (2) The setting range is within the temperature setting range specified in the Input range (buffer memory address: 20H, 40H, 60H, 80H) (refer to Section 3.5.12).
- (3) Setting a value outside the setting range, or setting other than 0 for the setting range in mode setting 0 will result in a write error and Write error flag (Xn2) turns ON.
- (4) The set value varies with the setting increments of Input range (buffer memory address: 20H, 40H, 60H, 80H)(refer to Section 3.5.12) as indicated below:
 - If the setting increments(1) without a decimal point is set, the value is set in increments of 1 degree Celsius.
 - If the setting increments(0.1) with a decimal point is set, the value is set in increments of 0.1 degree Celsius. (The value is indicated without a decimal point.)

3.5.17 Upper/lower output limiter

(buffer memory address: 2AH, 2BH, 4AH, 4BH, 6AH, 6BH, 8AH, 8BH)

- (1) Sets the upper and lower limit values for actually outputting the manipulated value (MV) calculated by PID operation to an external device.
- (2) The setting range is -50 to 1050 (-5.0% to 105.0%).
Make setting so that the (lower output limiter value) is less than the (upper output limiter value).

3.5.18 Output variation limiter (buffer memory address: 2CH, 4CH, 6CH, 8CH)

- (1) This function suppresses the variation of the manipulated value updated every second.
- (2) The setting range is 1 to 1000 (0.1 to 100.0%).
For example, when Output variation limiter (buffer memory address: 2CH, 4CH, 6CH, 8CH) is set to 10 (1.0%), the output variation will be 1% per second at a sudden manipulated value change of 50%, and it will take 50 seconds until the output value changes to 50% actually.
- (3) Setting 0 disables the output variation limiter function.
- (4) When two-position control is exercised, Output variation limiter (buffer memory address: 2CH, 4CH, 6CH, 8CH) is ignored.

3.5.19 Sensor compensation value setting (buffer memory address: 2DH, 4DH, 6DH, 8DH)

- (1) Sets the compensation value used when there is a difference between the measure temperature and the actual temperature due to measured temperature conditions, etc. (Refer to Section 3.2.4.)
- (2) Set the value within the range -5000 to 5000 (-50.00% to 50.00%) relative to the full scale of the preset Input range (buffer memory address: 20H, 40H, 60H, 80H).

3.5.20 Adjustment sensitivity (dead band) setting
(buffer memory address: 2EH, 4EH, 6EH, 8EH)

- (1) Sets the adjustment sensitivity for the set value to prevent chattering of the transistor output.
- (2) Set the sensitivity within the range 1 to 100 (0.1% to 10.0%) relative to the full scale of the preset Input range (buffer memory address: 20H, 40H, 60H, 80H).

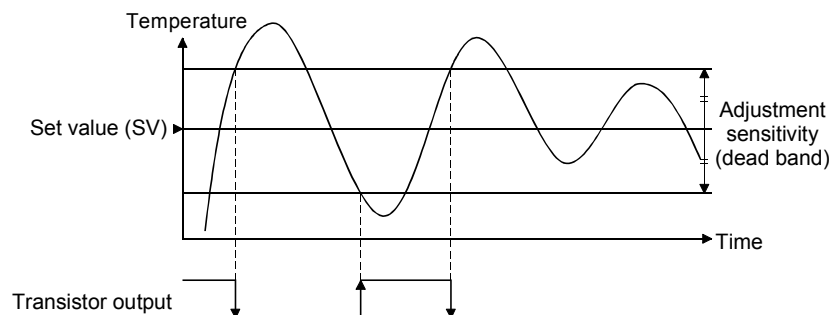

$$\frac{(\text{Full scale}) \times (\text{adjustment sensitivity})}{1000} = \frac{(400 - (-200)) \times 10}{1000} = 6.0 \text{ } ^\circ\text{C}$$

3.5.21 Control output period setting (buffer memory address: 2FH, 4FH, 6FH, 8FH)

- (1) Sets the pulse cycle (ON/OFF cycle) of the transistor output.

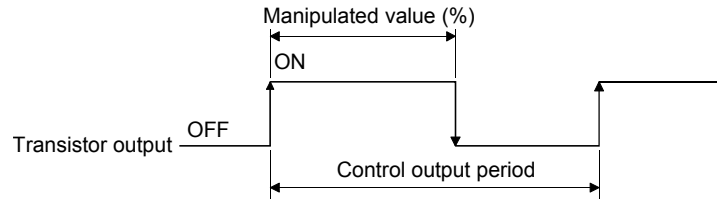

- (2) The setting range is 1 to 100 (1 to 100s).
- (3) The ON time of the control output period is found by multiplying the control output period by the manipulated value (%) calculated by PID operation. (Refer to Section 3.5.6.)

3.5.22 Primary delay digital filter setting (buffer memory address: 30H, 50H, 70H, 90H)

- (1) The primary delay digital filter is designed to absorb sudden changes when the process value (PV) is input in a pulse format.

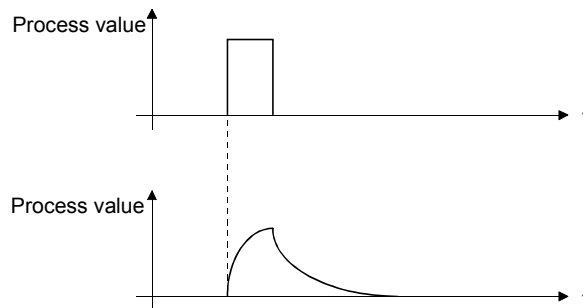

- (2) As the primary delay digital filter setting (filter setting time), specify the time for the PV value to change 63.3%.

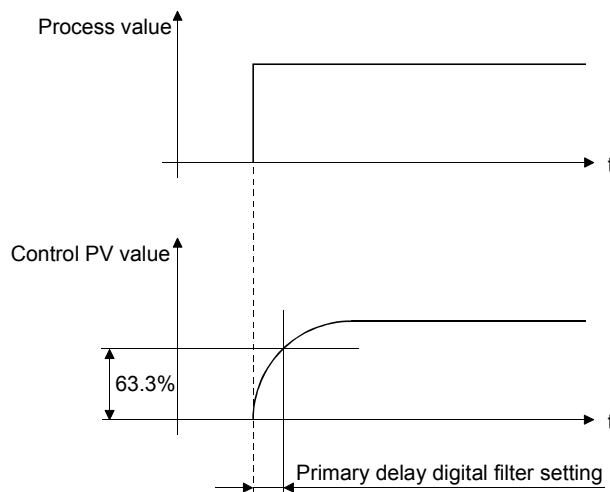

3.5.23 Control response parameter (buffer memory address: 31H, 51H, 71H, 91H)

- (1) The control response parameter is used to set the response to a PID control set value (SV) change in any of three levels (fast, normal and slow).
 - (a) Fast : Choose this level to give faster response to a set value change.
Note that the setting of "Fast" will increase overshooting.
 - (b) Slow : Choose this level to suppress the overshooting of a set value change.
Note that this will increase the settling time.
 - (c) Normal: Provides the intermediate characteristic between "Fast" and "Slow".

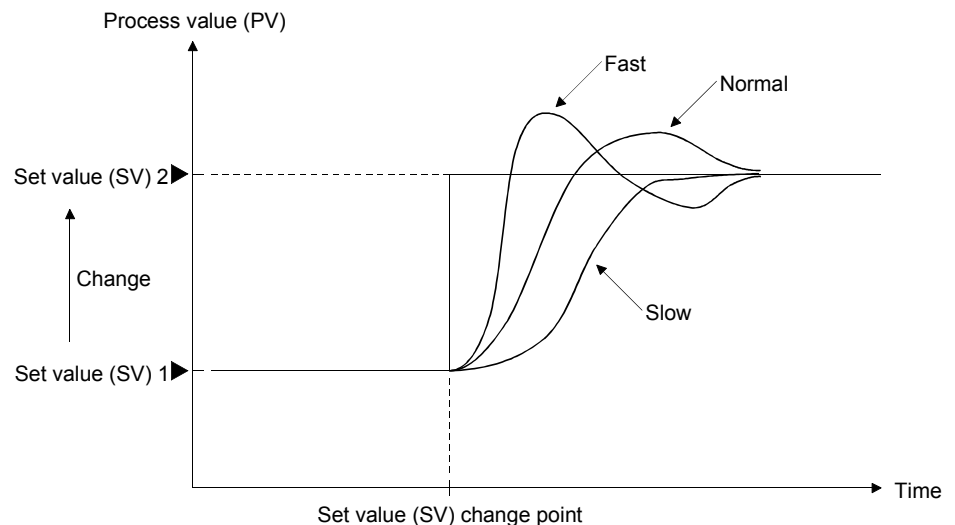

3.5.24 AUTO/MAN mode switching (buffer memory address: 32H, 52H, 72H, 92H)

- (1) This setting is made to select the manipulated value between the PID operation-calculated value and the user-set value.
 - AUTO : The manipulated value calculated by PID operation is used to calculate the ON time of the control period.
 - MAN : The manipulated value written to MAN output setting (buffer memory address: 33H, 53H, 73H, 93H) is used to calculate the ON time of the control period.
- (2) When AUTO is switched to MAN, the manipulated value calculated with PID operation is transferred to MAN output setting (buffer memory address: 33H, 53H, 73H, 93H) to prevent a sudden manipulated value change. (Bumpless switching)
On completion of switching to the manual mode, the corresponding bit of MAN mode shift completion flag (buffer memory address: 1EH) turns to 1 (ON).
Set the manipulated value in the MAN mode after making sure that the corresponding bit of the manual mode shift completion flag has turned on.
- (3) When executing auto tuning, set "0: Auto (AUTO)".
When the setting is "1: Manual (MAN)", auto tuning will not be executed.

3.5.25 MAN output setting (buffer memory address: 33H, 53H, 73H, 93H)

- (1) This area is used to set the manipulated value in the "MAN" mode.
- (2) Write a value to MAN output setting (buffer memory address: 33H, 53H, 73H, 93H) after confirming that the corresponding bit of MAN mode shift completion flag (buffer memory address: 1EH) has turned to 1 (on).
If this setting is made when the manual mode shift completion flag is off, the system will rewrite it to the manipulated value calculated by PID operation.

3.5.26 Setting change rate limiter (buffer memory address: 34H, 54H, 74H, 94H)

- (1) This setting is made to set the variation of the set value per minute to a set value (SV) change. This will suppress a derivative kick (sudden change in the manipulated value).

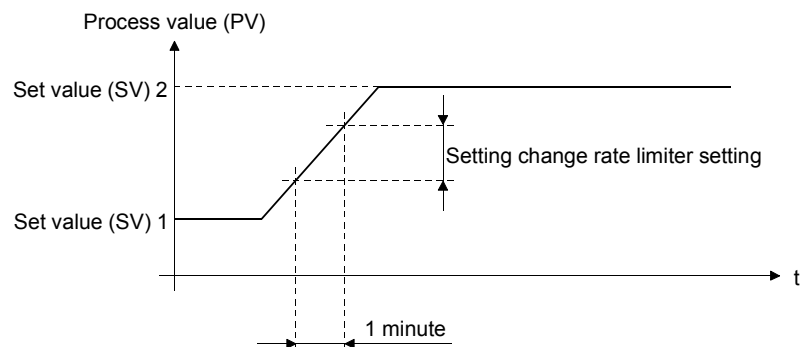

- (2) Make this setting as a percentage of Input range (buffer memory address: 20H, 40H, 60H, 80H) to the full scale.
The setting range is 0 to 1000 (0 to 100.0%/min).
When 0 is set, setting change rate limiter setting is invalid.

3.5.27 AT bias (buffer memory address: 35H, 55H, 75H, 95H)

- (1) This setting is made to perform auto tuning centering on a shifted point (AT point). Make this setting when shifting the point of the set value (SV) for auto tuning. Make this setting if an excess of the process value over the set value (SV) will be inconvenient for auto tuning.
- (2) Set the range which has minimal PID operation fluctuations and will not affect the control results.
Otherwise, exact PID constants may not be provided depending on the object to be controlled.
[Setting of AT bias on negative side (for reverse action)]

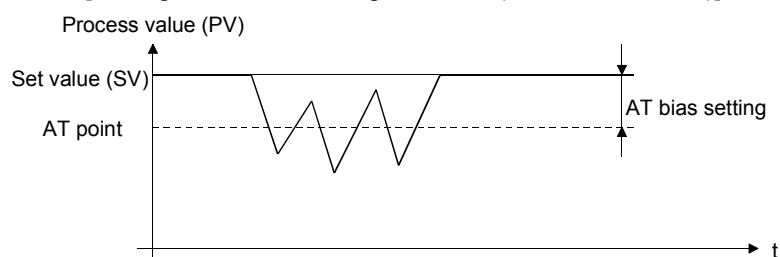

- (3) The setting range is \pm input range.

- (4) The set value varies with the setting increments of input range (buffer memory address: 20H, 40H, 60H, 80H)(refer to Section 3.5.12) as indicated below:
- If the setting increments(1) without a decimal point is set, the value is set in increments of 1 degree Celsius.
 - If the setting increments(0.1) with a decimal point is set, the value is set in increments of 0.1 degree Celsius. (The value is indicated without a decimal point.)

3.5.28 Forward/reverse action setting (buffer memory address: 36H, 56H, 76H, 96H)

- (1) Sets whether each channel of the Q64TC will be used for forward or reverse action.
 - Forward action (cooling control): 0
 - Reverse action (heating control): 1

3.5.29 Upper/lower setting limiter

(buffer memory address: 37H, 38H, 57H, 58H, 77H, 78H, 97H, 98H)

- (1) Sets the upper and lower limits of the set value (SV).
- (2) Set a value within the temperature measurement range specified for Input range (buffer memory address: 20H, 40H, 60H, 80H).
Make setting so that the (lower output limiter value) is less than the (upper output limiter value).

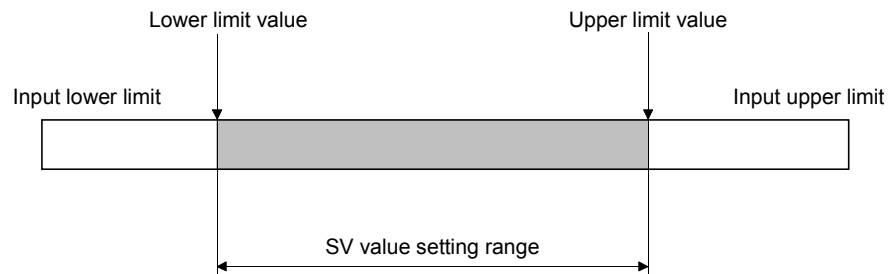

- (3) The set value varies with the setting increments of input range (buffer memory address: 20H, 40H, 60H, 80H)(refer to Section 3.5.12) as indicated below:
 - If the setting increments(1) without a decimal point is set, the value is set in increments of 1 degree Celsius.
 - If the setting increments(0.1) with a decimal point is set, the value is set in increments of 0.1 degree Celsius. (The value is indicated without a decimal point.)

3.5.30 Heater disconnection alert setting (buffer memory address: 3AH, 5AH, 7AH, 9AH)

- (1) Available only for the Q64TCTTBW and Q64TCRTBW.
- (2) Sets the set value for heater disconnection detection or output off-time current error detection as a percentage (%) of the reference heater current value.
- (3) The setting range is 0 to 100%.
When the value is 0, heater disconnection detection and output off-time current error detection are not performed.

3.5.31 Loop disconnection detection judgment time (buffer memory address: 3BH, 5BH, 7BH, 9BH)

- (1) The loop disconnection detection function detects errors in the control system due to a load disconnection, external operation device fault, sensor disconnection and the like.
No temperature change of greater than 2°C (2°F) within the loop disconnection detection judgment time is judged as a loop disconnection.
- (2) As the loop disconnection detection judgment time, set a value longer than the time taken to vary the temperature 2°C (2°F).
- (3) Performing auto tuning automatically sets a value twice longer than the integral time as the loop disconnection detection judgment time.
However, if the loop disconnection detection judgment time was set to 0 at the auto tuning, the loop disconnection detection judgment time is not stored.

3.5.32 Loop disconnection detection dead band (buffer memory address: 3CH, 5CH, 7CH, 9CH)

- (1) To prevent the false alarm of loop disconnection detection, set the non-alarm area (temperature width where loop disconnection will not be detected) around the set value.

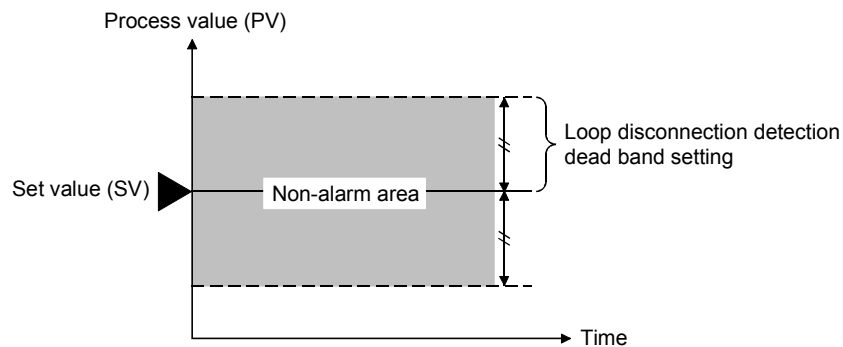

- (2) The setting range is within the temperature setting range specified in the Input range (buffer memory address: 20H, 40H, 60H, 80H) (refer to Section 3.5.12).
For example, if Loop disconnection detection dead band (buffer memory address: 3CH, 5CH, 7CH, 9CH) is "50" at the input range setting of 38, loop disconnection detection judgment is not made within the set value range of $\pm 5.0^{\circ}\text{C}$.
- (3) The set value varies with the setting increments of Input range (buffer memory address: 20H, 40H, 60H, 80H)(refer to Section 3.5.12) as indicated below:
 - If the setting increments(1) without a decimal point is set, the value is set in increments of 1 degree Celsius.
 - If the setting increments(0.1) with a decimal point is set, the value is set in increments of 0.1 degree Celsius. (The value is indicated without a decimal point.)

3.5.33 Unused channel setting (buffer memory address: 3DH, 5DH, 7DH, 9DH)

- (1) Used to specify as unused the channels where temperature control will not be performed and temperature sensors will not be connected.
- (2) For the channels set as unused, the "ALM" LED will not be lit if a temperature sensor is not connected.
- (3) Turning on Default setting registration start command (Yn9) clears the unused channel setting. When there are channels where temperature control is not performed and temperature sensors are not connected, make unused channel setting after completion of default setting registration.

3.5.34 E²PROM's PID constant read command (buffer memory address: 3EH, 5EH, 7EH, 9EH)

- (1) This command reads PID constants from E²PROM to buffer memory. Setting 1 (With command) to this command reads values in E²PROM to the following buffer memories.

Buffer memory address name	Address (Hexadecimal)			
	CH1	CH2	CH3	CH4
Proportional band (P) setting	23H	43H	63H	83H
Integral time (I) setting	24H	44H	64H	84H
Derivative time (D) setting	25H	45H	65H	85H
Loop disconnection detection judgment time	3BH	5BH	7BH	9BH

- (2) This function is the most suitable for use when you want to use the initial settings of the utility and the PID constants backed up on E²PROM together.
- (3) When 1 (With command) is set to this command, do not perform the setting value change, E²PROM backup, and default setting registration.
- (4) When executing auto tuning, set 0 (Without command) to this command. If auto tuning is executed while setting 1 (With command) to the command, even if internal processing of auto tuning is completed and PID constant is stored, Auto tuning status (Xn4 to Xn7) does not turn OFF and auto tuning is not completed.

3.5.35 Automatic backup setting after auto tuning of PID constants (buffer memory address: 3FH, 5FH, 7FH, 9FH)

- (1) With this function, the PID constants set at completion of auto tuning are backed up automatically by E²PROM.

When 1 is written to this setting and auto tuning then started, data at the following buffer memory addresses are automatically backed up by E²PROM on completion of auto tuning.

Buffer memory address name	Address (Hexadecimal)			
	CH1	CH2	CH3	CH4
Proportional band (P) setting	23H	43H	63H	83H
Integral time (I) setting	24H	44H	64H	84H
Derivative time (D) setting	25H	45H	65H	85H
Loop disconnection detection judgment time	3BH	5BH	7BH	9BH

- (2) Do not change this setting during execution of auto tuning.
- (3) While auto tuning is being executed with this setting valid, do not make a set value change, E²PROM backup and default setting registration.

3.5.36 Alert dead band setting (buffer memory address: A4H)

Sets the dead band for alerts.

Set it within the range 0 to 100 (0.0% to 10.0%) to the full scale of the set input range.

Example) When the input range 2 (0 to 1300°C) and alert dead band setting 5 (0.5%) are selected

$$\frac{(\text{Full scale}) \times (\text{Alert dead band})}{1000} = \frac{(1300-0) \times 5}{1000} = 6.5 \text{ C}$$

For details, refer to Section 3.2.11 (2).

3.5.37 Alert delay count (buffer memory address: A5H)

- (1) Sets the sampling count for judging an alert.

When the alert delay count has been set, the system is placed in an alert status if the sampling count remains within the alert range between when the process value (PV) has fallen within the alert range and when the sampling count reaches or exceeds the alert delay count.

Refer to Section 3.2.11 for details.

- (2) The setting range is 0 to 255.

3.5.38 Heater disconnection/output off-time current error detection delay count (buffer memory address: A6H)

- (1) Available only for the Q64TCTTBW and Q64TCRTBW.
- (2) Sets how many heater disconnection detection and output off-time current detection errors will occur consecutively before alert judgment is made.
- (3) The setting range is 3 to 255.

3.5.39 Temperature rise completion range setting (buffer memory address: A7H)

- (1) Sets the temperature rise/fall values, at which a temperature rise will be judged as completed, relative to the set value.

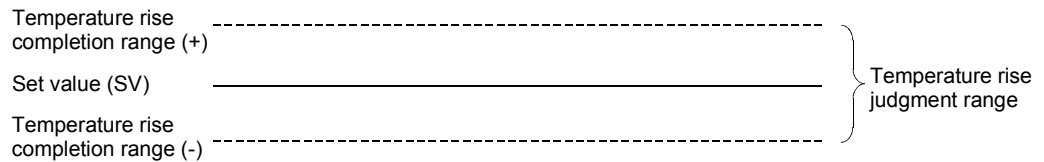

- (2) The setting range is 1 to 10°C.

3.5.40 Temperature rise completion soak time setting (buffer memory address: A8H)

- (1) Sets a delay from when a temperature rise is completed until the temperature rise completion judgment flag is turned on (1).
- (2) The setting range is 0 to 3600 (min).

3.5.41 PID continuation flag (buffer memory address: A9H)

- (1) Sets the operation mode to be entered when Operation mode command (Yn1) turns from on to off.
- 0: Stop (default)
 - 1: Continue
- (2) Refer to Section 3.2.13 for the control status governed by on/off of the PID continuation flag.

3.5.42 Heater disconnection compensation function selection (buffer memory address: AAH)

- (1) Available only for the Q64TCTTBW and Q64TCRTBW.
- (2) Sets whether the heater disconnection compensation function (refer to Section 3.2.7) is used or not.
- 0: Heater disconnection compensation function is not used (default)
 - 1: Heater disconnection compensation function is used

3.5.43 Transistor output monitor ON delay time setting (buffer memory address: AFH)

- (1) Make this setting to delay the timing when the transistor output flag (buffer memory address: 15H to 18H.b8) turns on.
Set this when performing heater disconnection detection by using the input module.
- (2) The setting range is 0 and 1 to 50 (10 to 500ms).
When the setting is 0, the transistor output flag (buffer memory address: 15H to 18H.b8) does not turn on (1).

3.5.44 CT monitor method switching (buffer memory address: B0H)

- (1) Available only for the Q64TCTTBW and Q64TCRTBW.
- (2) Sets the method of making heater current measurement.
 Choosing the ON current/OFF current measures the present current value of the CT.
 Choosing the ON current holds (retains) the previous heater ON-time current value when the heater is OFF.
 - 0: ON current/OFF current (default)
 - 1: ON current

3.5.45 Manipulated value

(0 to 4000/0 to 12000/0 to 16000) (buffer memory address: B1H to B4H)

- (1) Stores the value of the manipulated value at Manipulated value (MV) (buffer memory address: D_H to 10_H) to be output to the digital-to-analog converter module.
- (2) The value stored is in the range 0 to 16000.
- (3) When the equipment to be heated or cooled is analog input equipment, output the manipulated value to the digital-to-analog converter module to convert it into an analog value.

3.5.46 Manipulated value resolution switching (buffer memory address: B5H)

- (1) Choose any of the following three different resolutions for Manipulated value (MV) (buffer memory address: D_H to 10_H).
 - 0: 0 to 4000 (default)
 - 1: 0 to 12000
 - 2: 0 to 16000
 The output value is stored at Manipulated value (0 to 4000/0 to 12000/0 to 16000, buffer memory address: B1H to B4H) (refer to Section 3.5.45)

3.5.47 Auto tuning mode selection (buffer memory address: B8H to BBH)

According to the controlled object to be used, choose the auto tuning mode from the "standard mode" and "fast response mode".

The standard mode is compatible with almost all controlled objects.

(1) Standard mode

This mode is compatible with almost all controlled objects. This mode is especially effective for controlled objects which give an extremely slow response or which may be affected by noise or interference.

For the controlled object where either the ON or OFF time during auto tuning is about only 10 seconds, slow-response (low-gain) PID constants may be calculated. In this case, fast-response PID constants can be calculated by executing auto tuning in the fast response mode.

(2) Fast response mode

This mode calculates faster-response (higher-gain) PID constants for the controlled object which gives a fast response where the ON or OFF time during auto tuning is about only 10 seconds.

Note that the gains of the calculated PID constants may become so high that the control temperature (PV) may oscillate near the set value (SV). In this case, execute auto tuning in the standard mode.

POINT
(1) If auto tuning mode selection is performed using the utility package, Version 1.10L or a subsequent product version is necessary.
(2) If the fast response mode is set to the module with function version A, an error (error code: 2) occurs. Switch the mode to the standard mode.

3.5.48 Alert 1 to 4 mode setting

(buffer memory address: C0H to C3H, D0H to D3H, E0H to E3H, F0H to F3H)

- (1) Sets the alert mode which gives an alarm.
No alert will be given if "0" is set to Alert set value 1 to 4 (buffer memory address: 26H to 29H, 46H to 49H, 66H to 69H, 86H to 89H).
- (2) The alert function will not be executed if "0" is set to the alert 1 to 4 mode setting buffer memory (C0H to C3H, D0H to D3H, E0H to E3H, F0H to F3H)
 - Channel 1: 26H to 29H
 - Channel 2: 46H to 49H
 - Channel 3: 66H to 69H
 - Channel 4: 86H to 89H
- (3) The correspondences between buffer memory addresses and channels are listed below.

Mode setting item	CH1	CH2	CH3	CH4
Alert 1	C0H	D0H	E0H	F0H
Alert 2	C1H	D1H	E1H	F1H
Alert 3	C2H	D2H	E2H	F2H
Alert 4	C3H	D3H	E3H	F3H

- (4) The following table indicates the alert modes and set values.
Refer to Section 3.2.11 for the alerts of the Q64TC.

Alert mode	Setting	Alert mode	Setting	Alert mode	Setting
Upper limit input alert	1	Upper limit input alert with wait	7	—	—
Lower limit input alert	2	Lower limit input alert with wait	8	—	—
Upper limit deviation alert	3	Upper limit deviation alert with wait	9	Upper limit deviation alert with re-wait	12
Lower limit deviation alert	4	Lower limit deviation alert with wait	10	Lower limit deviation alert with re-wait	13
Upper/lower limit deviation alert	5	Upper/lower limit deviation alert with wait	11	Upper/lower limit deviation alert with re-wait	14
Within-range alert	6	—	—	—	—

3.5.49 Heater current process value (buffer memory address: 100H to 107H)

- (1) Stores the heater current detected by the Q64TC.
- (2) Stores the value within the range set for CT selection (buffer memory address: 110H to 117H).
Held at the upper limit value if the heater current value exceeds the upper limit value of the measurement range.

POINT
Either of the following values must be set to start heater current measurement. <ul style="list-style-type: none"> • CT input channel assignment setting (buffer memory address: 108H to 10FH) • Reference heater current value (buffer memory address: 118H to 11FH) When both are 0, heater current measurement is not made.

3.5.50 CT input channel assignment setting (buffer memory address: 108H to 10FH)

- (1) Sets how the CT inputs will be assigned to the channels.
- (2) The following table lists the CT inputs and set values.

CT input	Buffer memory address	Set value
CT1	108H	Assignment is made by writing any of the following values to each address indicated on the left. 0: Unused (default) 1: Channel 1 2: Channel 2 3: Channel 3 4: Channel 4
CT2	109H	
CT3	10AH	
CT4	10BH	
CT5	10CH	
CT6	10DH	
CT7	10EH	
CT8	10FH	

- (3) When a three-phase heater is used, the same channel is assigned to two CT inputs. Refer to Section 4.4.3 for the setting example.

3.5.51 CT selection (buffer memory address: 110H to 117H)

- (1) Chooses the current sensor connected to the Q64TCTTBW or Q64TCRTBW.
 - 0: When CTL-12-S36-8 is used (0 to 100.0A) (default)
 - 1: When CTL-6-P(-H) is used (0 to 20.00A)
- (2) To determine a change in the set value, Setting change command (YnB) must be turned on.

POINT
Refer to Section 2.1 for the current sensors that can be used with the Q64TCTTBW and Q64TCRTBW. We cannot guarantee operation if any other current sensor (CT) is used.

3.5.52 Reference heater current value (buffer memory address: 118H to 11FH)

- (1) Sets Heater current process value (buffer memory address: 100H to 107H) when the heater is on.
- (2) The setting ranges are indicated below.
 - When CTL-12-S36-8 is used : 0 to 1000 (0 to 100.0A)
 - When CTL-6-P(-H) is used : 0 to 2000 (0 to 20.00A)

4 SETUP AND PROCEDURE BEFORE STARTING THE OPERATION

The following describes the procedure prior to the Q64TC operation, the name and setting of each part of the Q64TC, and wiring method.

4.1 Handling Precautions

The following are the precautions for handling the Q64TC.

- (1) Do not drop the module casing or connector, or do not subject it to strong impact.
- (2) Do not remove the PCB of each module from its case. Doing so may cause breakdowns.
- (3) Be careful not to let foreign particles such as wire chips get inside the module. These may cause fire, breakdowns and malfunctions.
- (4) The top surface of the module is covered with a protective film to prevent foreign objects such as wire chips from entering the module when wiring. Do not remove this film until the wiring is complete.
Before operating the system, be sure to remove the film to provide adequate heat ventilation.
- (5) Tighten the screws such as module fixing screws within the following ranges. Loose screws may cause short circuits, failures, or malfunctions.

Screw location	Tightening torque range
Module fixing screw (M3 screw) * 1	0.36 to 0.48N·m
Terminal block terminal screw (M3 screw)	0.42 to 0.58N·m
Terminal block fixing screw (M3.5 screw)	0.66 to 0.89N·m

* 1: The module can be easily fixed onto the base unit using the hook at the top of the module. However, it is recommended to secure the module with the module fixing screw if the module is subject to significant vibration.

- (6) While pressing the installation lever located at the bottom of module, insert the module fixing tab into the fixing hole in the base unit until it stops. Then, securely mount the module with the fixing hole as a supporting point.
Improper installation may result in malfunction, breakdown or the module coming loose and dropping. Securely fix the module with screws if it is subject to vibration during use.

4.2 Procedure Before Starting the Operation

The figure below shows the steps that should be followed before starting the Q64TC operation.

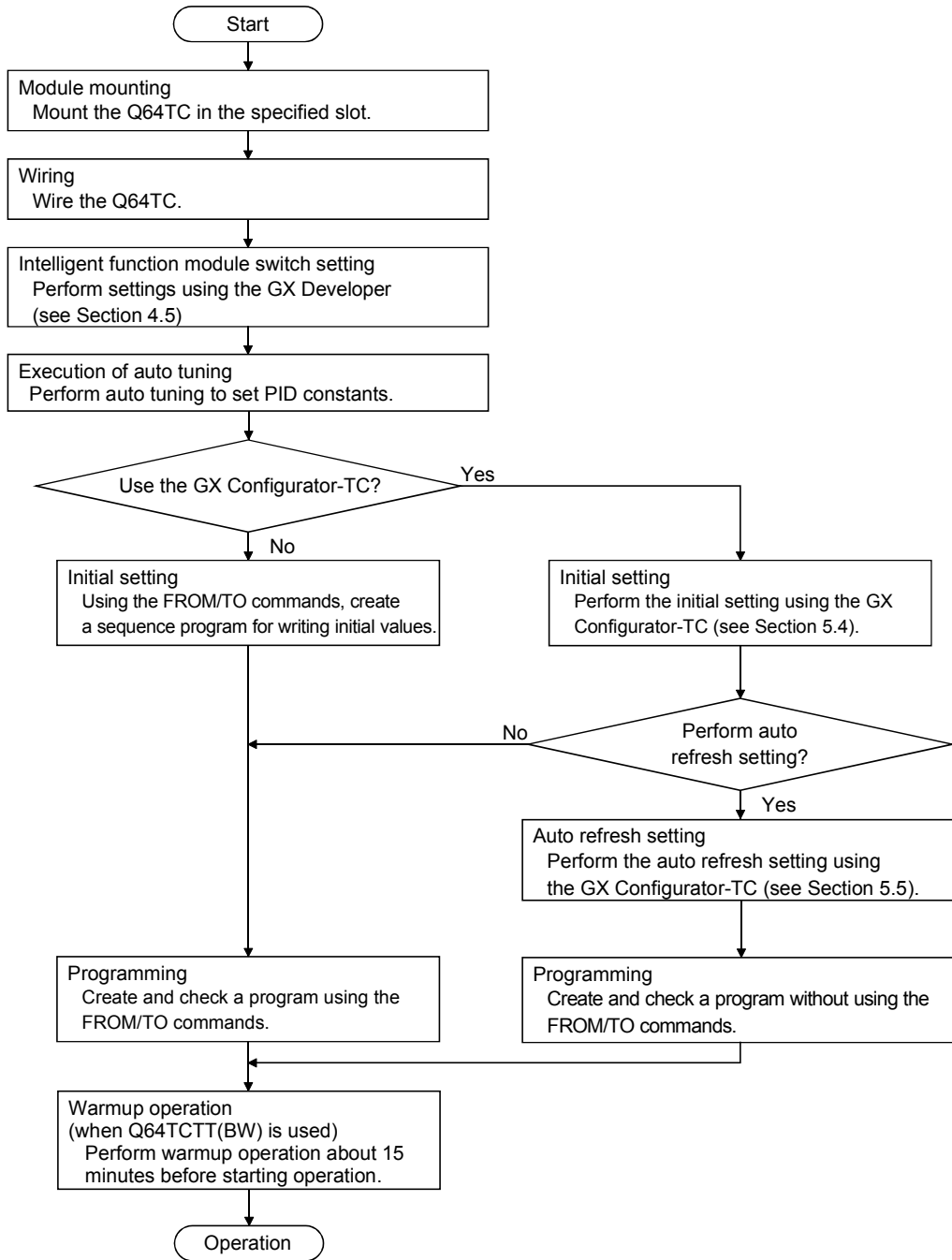

POINT

When using the Q64TCTT(BW) which uses a thermocouple as a temperature sensor, perform warmup operation about 15 minutes before starting operation to make temperature compensation properly.

4.3 Parts Identification

This section explains the names of the Q64TC parts.

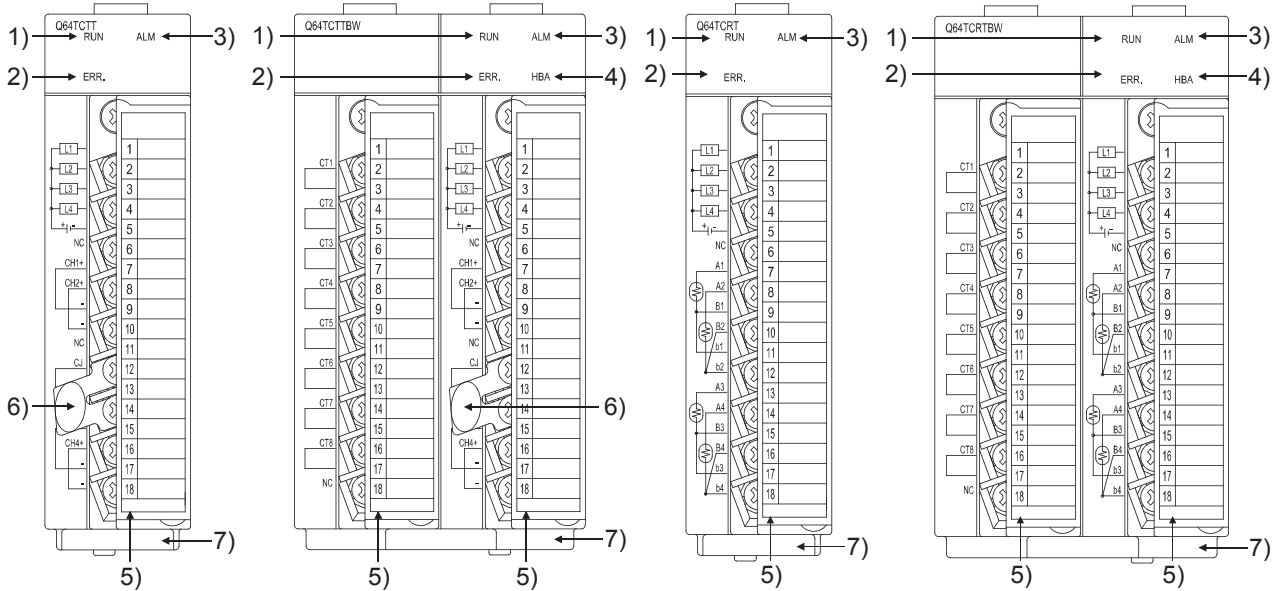

Number	Name	Description
1)	RUN LED	Indicates the operating status of the Q64TC On: Operating normally. Off: 5V power is off, watchdog timer error occurred, or CPU stop error occurred with intelligent function module switches of all channels set to "CLEAR".
2)	ERR. LED	Indicates the error status of the Q64TC On : Hardware fault (Including no connection of a cold junction temperature compensation resistor) Flicker : Write data error occurring Off : Operating normally.
3)	ALM LED	Indicates the alert status of the Q64TC On : Alert occurring Flicker : Process value (PV) came out of measured temperature range. Loop disconnection was detected. Sensor is not connected. Off : Alert not occurring
4)	HBA LED	Indicates the heater disconnection detection status of the Q64TCTTBW and Q64TCRTBW. On: Heater disconnection was detected. Off: Heater disconnection is not detected.
5)	Terminal block*1	Used for temperature sensor input, transistor output and current sensor (CT) input.
6)	Cold junction temperature compensation resistor	Used when cold junction temperature compensation is made.
7)	Serial number plate	Indicates the serial No. of the Q64TC.

*1: The terminal block layout varies with the module used.

Respective terminal block layouts are indicated on the following pages.

(1) When using the Q64TCTT

Terminal number	Signal name
1	L1
2	L2
3	L3
4	L4
5	COM-
6	Unused
7	CH1+
8	CH2+
9	CH1-
10	CH2-
11	Unused
12	CJ
13	Unused
14	CJ
15	CH3+
16	CH4+
17	CH3-
18	CH4-

(2) When using the Q64TCTTBW

Terminal number	Signal name	
1	Unused	L1
2	CT1	L2
3	CT1	L3
4	CT2	L4
5	CT2	COM-
6	CT3	Unused
7	CT3	CH1+
8	CT4	CH2+
9	CT4	CH1-
10	CT5	CH2-
11	CT5	Unused
12	CT6	CJ
13	CT6	Unused
14	CT7	CJ
15	CT7	CH3+
16	CT8	CH4+
17	CT8	CH3-
18	Unused	CH4-

(3) When using the Q64TCRT

Terminal number	Signal name
1	L1
2	L2
3	L3
4	L4
5	COM-
6	Unused
7	A1
8	A2
9	B1
10	B2
11	b1
12	b2
13	A3
14	A4
15	B3
16	B4
17	b3
18	b4

(4) When using the Q64TCRTBW

Terminal number	Signal name	
1	Unused	L1
2	CT1	L2
3	CT1	L3
4	CT2	L4
5	CT2	COM-
6	CT3	Unused
7	CT3	A1
8	CT4	A2
9	CT4	B1
10	CT5	B2
11	CT5	b1
12	CT6	b2
13	CT6	A3
14	CT7	A4
15	CT7	B3
16	CT8	B4
17	CT8	b3
18	Unused	b4

4.4 Wiring

This section provides wiring instructions and module connection examples.

4.4.1 Wiring precautions

External wiring must be noise-resistant as one of the conditions to fully exhibit the Q64TC functions and configure a highly reliable system.

The instructions given below should be followed in wiring.

- (1) Use separate cables with the AC control circuit and the Q64TC's external input signals to avoid the influence of AC side surges and induction.
- (2) Do not run the cables close to, or bundle them with, the main circuit and high-voltage cables and the load cables from other than the programmable controller. Always keep temperature sensors at least 100mm(3.94inch) away from the main circuit cables and AC control circuit. Fully keep them away from high-voltage cables and circuits which include higher harmonics, e.g. inverter load's main circuit. Failure to do so will make the cables susceptible to noise, surges and induction.
- (3) Ground the shield wires or shield cables to FG of the programmable controller. Note that it may be better to establish a ground on the external side depending on the external noise conditions.
- (4) When you want the equipment to conform with the EMC Directive/Low Voltage Directive, refer to "Conformance with the EMC Directive and Low Voltage Directive" in this manual and carry out wiring.

4.4.2 External wiring

(1) For use of the Q64TCTT

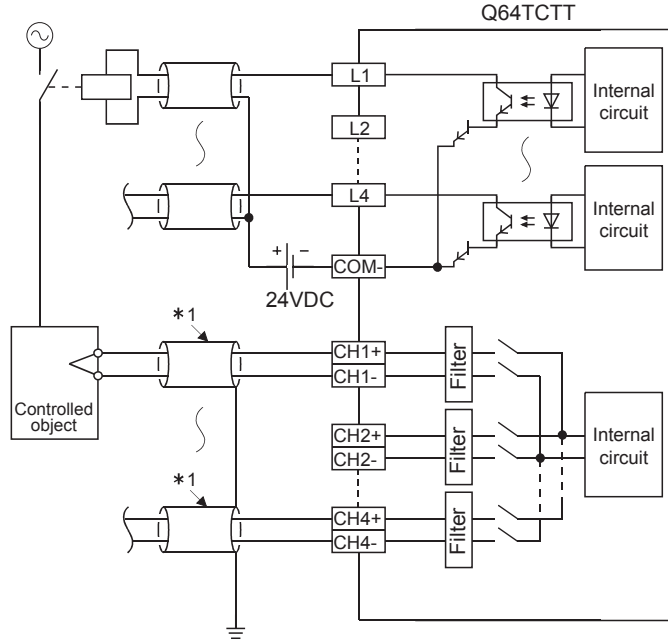

*1: Please use shielded compensation conductors.

POINT
<p>When the cold junction temperature compensation resistor is away from the end tip of thermocouple (or the end tip of compensation conductor), the (ambient) temperature difference may lead to a faulty temperature process value.</p> <p>Reference junction Thermocouple extension wire (OK) Cable (NG)</p> <p>A Cold junction temperature compensation resistor</p> <p>(Ambient) temperature difference B</p> <p>Terminal block</p> <p>Q64TCTT(BW)</p> <p>A: Reference junction of the □ thermocouple B: Cold junction temperature □ compensation resistor</p>

(2) For use of the Q64TCTTBW

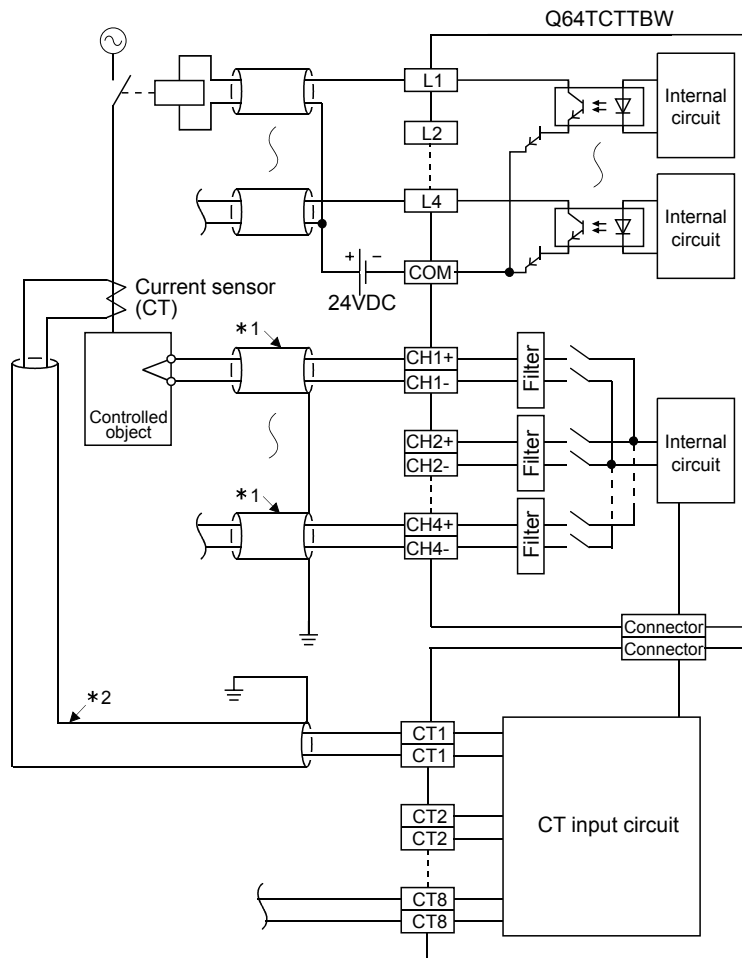

- *1: Please use shielded compensation conductors.
- *2: Always use shielded cables.

POINT

To use the heater disconnection detection function, CT input channel assignment setting must be made.

Since the above wiring example uses the CT1 in the loop of channel 1, set 1 (channel 1) to the CT1 in the CT input channel assignment setting (buffer memory address: 108H).

(3) For use of the Q64TCRT

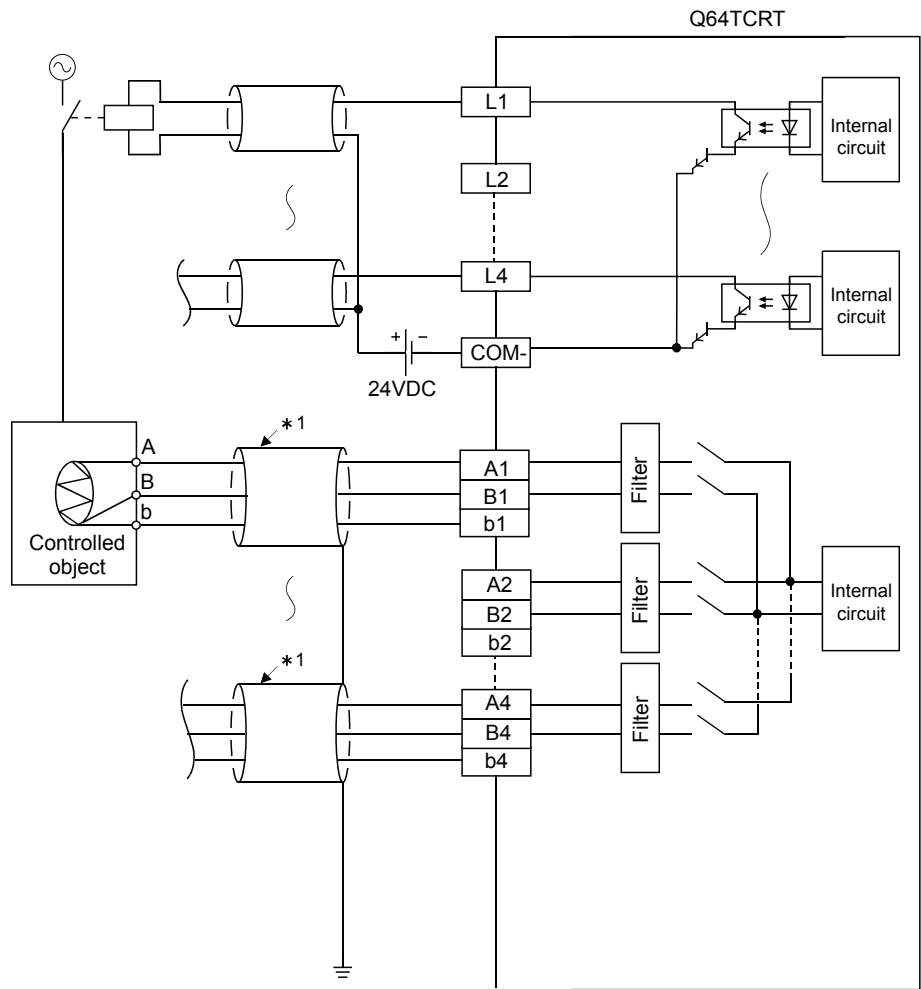

*1: Always use shielded cables.

(4) For use of the Q64TCRTBW

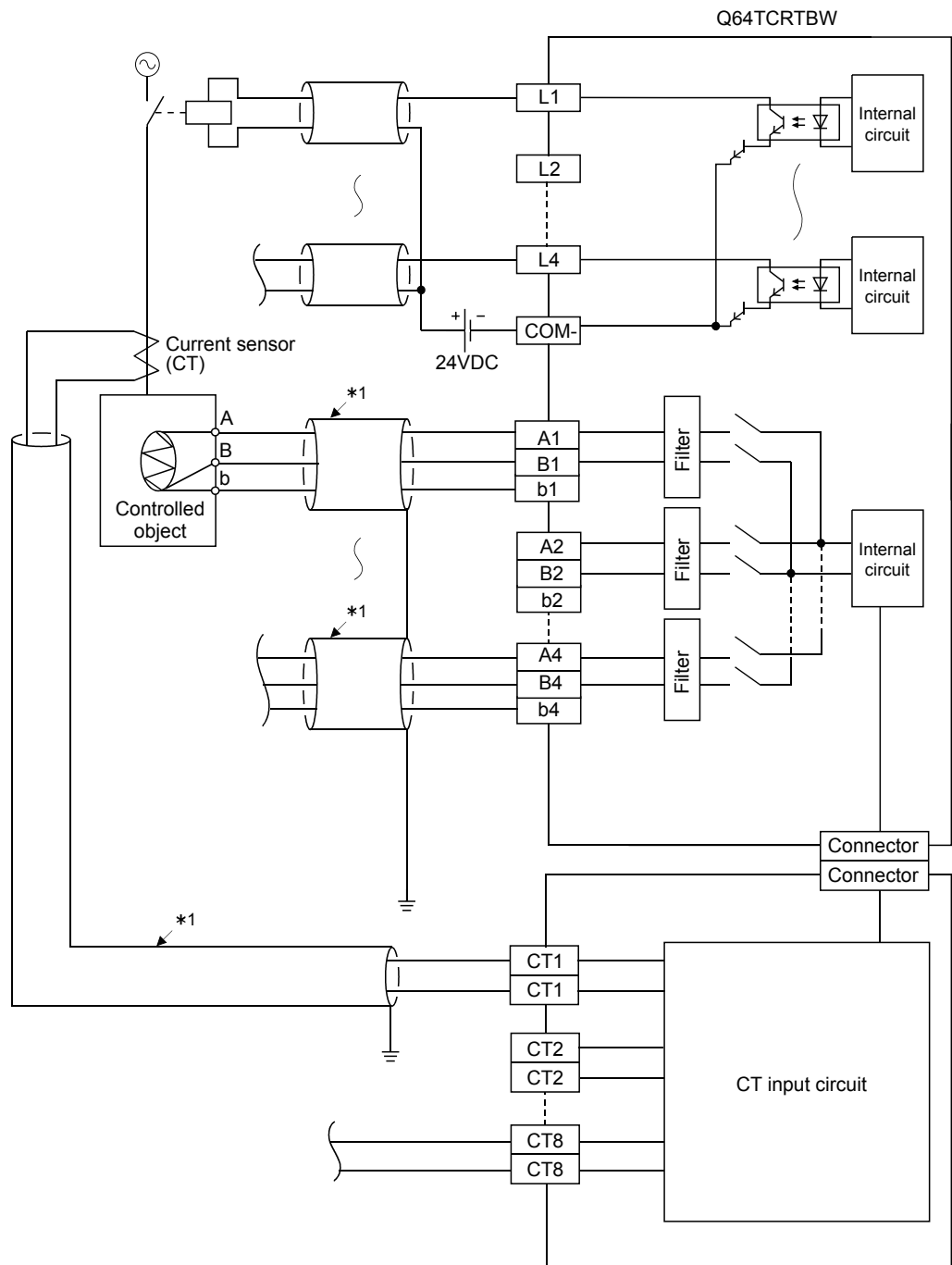

*1: Always use shielded cables.

POINT

To use the heater disconnection detection function, CT input channel assignment setting must be made.

Since the above wiring example uses the CT1 in the loop of channel 1, set 1 (channel 1) to the CT1 in the CT input channel assignment setting (buffer memory address: 108H).

4.4.3 Heater disconnection detection wiring and setting example for use of three-phase heater

The following wiring and setting example given below is designed to detect a three-phase heater disconnection using the heater disconnection detection function.

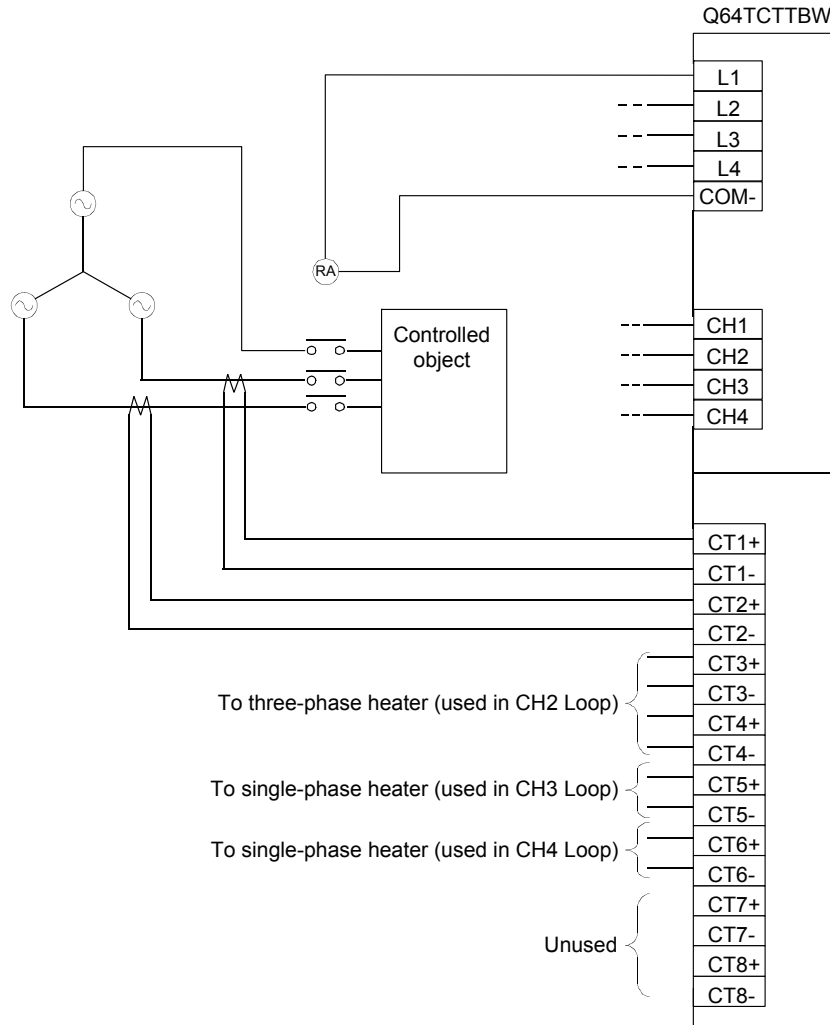

Three-phase heater disconnection detection is made by measuring the currents of two of the three conductors.

In the above wiring example, make CT input channel assignment setting (buffer memory address: 108H to 10FH) as indicated below.

CT input	Buffer memory address	Set value
CT1	108H	1
CT2	109H	1
CT3	10AH	2
CT4	10BH	2
CT5	10CH	3
CT6	10DH	4
CT7	10EH	0
CT8	10FH	0

4.5 Switch Settings for the Intelligent Function Module

This section explains the intelligent function module switch settings.

Make intelligent function module switch settings in I/O assignment setting on GX Developer.

Making intelligent function module switch settings allows you to set to the Q64TC the output status to be established when the programmable controller CPU has comes to an error stop.

Refer to Section 3.2.12 for setting details.

(1) Setting items

Five switches (switch numbers 1 to 5) are available for the intelligent function module and they are set with 16 bit data.

If the switches for the intelligent function module are not set, the default value of 0 is used for switches 1 to 5.

	Setting items					
Switch 1	<input type="checkbox"/>	<input type="checkbox"/>	<input type="checkbox"/>	<input type="checkbox"/>	H	Output setting for CPU stop error 0 : CLEAR Other than 0 : HOLD
	CH4	CH3	CH2	CH1		
Switch 2	Reserved					
Switch 3	Reserved					
Switch 4	Reserved					
Switch 5	Reserved					

(2) Operating procedure

Perform settings, starting with the GX Developer I/O assignment screen.

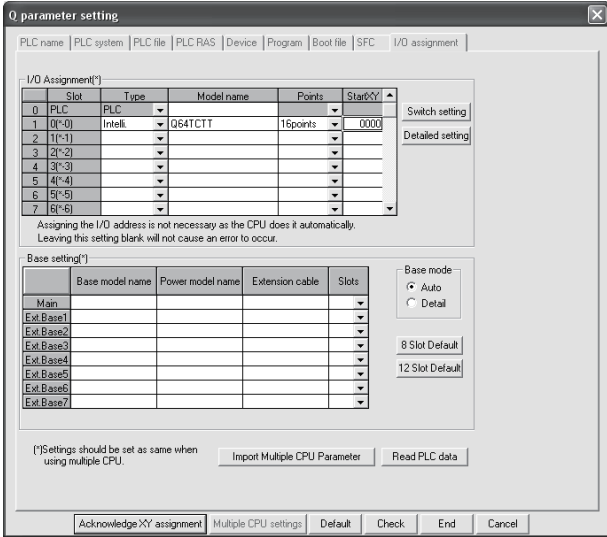

(a) I/O assignment screen

Specify the following for the slot where the Q64TC is mounted.

- Type : Select "Intelli."
- Model name : Enter the module's model name.
- Points : Select 16 points.
- Start XY : Enter the start I/O signal for the Q64TC.

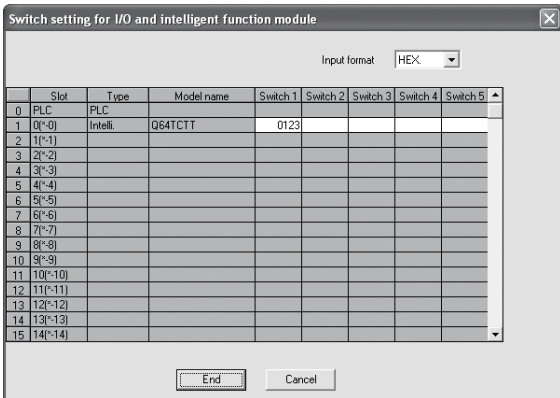

(b) Switch setting for I/O and intelligent function module

Click on **Switch Setting** on the I/O assignment screen to display the screen at left and set switches 1 to 5. The setting can easily be done if values are entered in hexadecimal. Change the input format to hexadecimal and enter values.

REMARK

You need not set the "error-time output mode" and "hardware error-time CPU operation mode" in the intelligent function module detailed setting as they are invalid for the Q64TC.

5 UTILITY PACKAGE (GX Configurator-TC)

5.1 Functions of the Utility Package

Table 5.1 lists the functions of the utility package.

Table 5.1 Utility package (GX Configurator-TC) function list

Function	Description	Reference section
Initial setting	<p>(1) Make initial setting for operating the temperature control module channel-by-channel. Set the values of the items which require initial setting.</p> <ul style="list-style-type: none"> • CH□ Input Range • CH□ Set Value (SV) Setting • CH□ Proportional Band (P) Setting • CH□ Integral Time(I) Setting • CH□ Derivative Time(D) Setting • CH□ Control Output Period Setting • CH□ Control Response Parameter • CH□ Stop Mode Setting • PID Continuation Flag • CH□ Alert 1 Mode Setting • CH□ Alert Set Value1 • CH□ Alert 2 Mode Setting • CH□ Alert Set Value2 • CH□ Alert 3 Mode Setting • CH□ Alert Set Value3 • CH□ Alert 4 Mode Setting • CH□ Alert Set Value4 • Alert Dead Band Setting • Alert Delay Count • CH□ Loop Disconnection Detection Judgment Time • CH□ Loop Disconnection Detection Dead Band • CH□ Heater Disconnection Alert Setting • Heater Disconnection/Output Off-time Current Error Detection Delay Count • Heater Disconnection Compensation Function Selection • CT Monitor Method Switching • CT□ Channel Assignment Setting • CT□ CT Selection • CT□ Reference Heater Current Value • CH□ Upper Setting Limiter • CH□ Lower Setting Limiter • CH□ Forward/Reverse Action Setting • CH□ Setting Change Rate Limiter • CH□ Sensor Compensation Value Setting • CH□ Primary Delay Digital Filter Setting • CH□ Upper Output Limiter • CH□ Lower Output Limiter • CH□ Output Variation Limiter • CH□ Adjustment Sensitivity (Dead Band) Setting • CH□ AT Bias • CH□ Auto Tuning Mode Selection • CH□ Unused Channel Setting • Transistor Output Monitor ON Delay Time Setting • Manipulated Value Resolution Switching • Temperature Rise Completion Range Setting • Temperature Rise Completion Soak Time Setting <p>(2) The initially set data are registered to the programmable controller CPU parameters, and when the programmable controller CPU is set to the RUN mode, they are written to the temperature control module automatically.</p>	Section 5.4

Function	Description	Reference section
Auto refresh setting	<p>(1) The temperature control module buffer memory is configured for automatic refresh channel-by-channel.</p> <ul style="list-style-type: none"> • Write Data Error Code • CH□ Temperature Process Value(PV) • CH□ Manipulated Value (MV) • CH□ Set Value (SV) Setting • CH□ Transistor Output Flag • CH□ Alert Definition • CH□ Alert Set Value1 • CH□ Alert Set Value2 • CH□ Alert Set Value3 • CH□ Alert Set Value4 • CH□ Proportional Band (P) Setting • CH□ Integral Time(I) Setting • CH□ Derivative Time(D) Setting • CH□ Loop Disconnection Detection Judgement Time • CT □ Heater Disconnection Alert Setting • CT □ Heater Current Process Value • CH□ Manipulated Value • CH□ Temperature Rise Judgment Flag <p>(2) Values set for auto refresh and stored in the temperature control module buffer memory are automatically read out when the END instruction is executed in the programmable controller CPU.</p>	Section 5.5
Monitor/test	<p>The buffer memory of the temperature control module and I/O signals are monitored or tested. The auto tuning function is also available.</p> <ul style="list-style-type: none"> • Write Data Error Code • CH□ Decimal Point Position • CH□ Temperature Process Value(PV) • CH□ Manipulated Value (MV) • CH□ Set Value (SV) Setting • CH□ Transistor Output Flag • CH□ ON Delay Output • Q64TCTT(BW) Cold Junction Temperature Process Value • X00:Module Ready Flag • X01:Operation Mode Status • X02:Write Error Flag • X03:Hardware Error Flag • X04:CH1 Auto Tuning Status • X05:CH2 Auto Tuning Status • X06:CH3 Auto Tuning Status • X07:CH4 Auto Tuning Status • X08:E²PROM Write Completion Flag • X09: Default Value Write Completion Flag • X0A:E²PROM Write Failure Flag • X0B:Setting Change Completion Flag • X0C:CH1 Alert Occurrence Flag • X0D:CH2 Alert Occurrence Flag • X0E:CH3 Alert Occurrence Flag • X0F:CH4 Alert Occurrence Flag • Y01:Operation Mode Command • Y02:Error Reset Command • Y04:CH1 Auto Tuning Command • Y05:CH2 Auto Tuning Command • Y06:CH3 Auto Tuning Command • Y07:CH4 Auto Tuning Command • Y08:E²PROM Backup Start Command • Y09:Default Setting Registration Start Command • Y0B:Setting Change Command • Y0C:CH1 Forced PID Control Stop Command • CH□ Alert1 • CH□ Alert2 • CH□ Alert3 • CH□ Alert4 • CH□ Heater Disconnection Alert • CH□ Loop Disconnection Alert • CH□ Output Off-time Current Error Alert • CH□ Alert1 Mode Setting • CH□ Alert Set Value1 • CH□ Alert2 Mode Setting • CH□ Alert Set Value2 • CH□ Alert3 Mode Setting • CH□ Alert Set Value3 • CH□ Alert4 Mode Setting • CH□ Alert Set Value4 • Alert Dead Band Setting • Alert Delay Count • CH□ Loop Disconnection Detection Judgment Time • CH□ Loop Disconnection Detection Dead Band • CH□ Heater Disconnection Alert Setting • Heater Disconnection/Output Off-time Current Error Detection Delay Count • Heater Disconnection Compensation Function Selection • CT Monitor Method Switching • CT□ Heater Current Process Value • CT□ Channel Assignment Setting • CT□ CT Selection • CT□ Reference Heater Current Value • CH□ Manipulated Value • Manipulated Value Resolution Switching • CH□ Temperature Rise Judgment Flag • Temperature Rise Completion Range Setting • Temperature Rise Completion Soak Time Setting 	Section 5.6

Function	Description	Reference section
Monitor/test	<ul style="list-style-type: none"> • Y0D:CH2 Forced PID Control Stop Command • Y0E:CH3 Forced PID Control Stop Command • Y0F:CH4 Forced PID Control Stop Command • CH□ Proportional Band (P) Setting • CH□ Integral Time(I) Setting • CH□ Derivative Time(D) Setting • CH□ PID Constant Read Command from EEPROM • CH□ EEPROM PID Constant Read Completion Flag • CH□ EEPROM PID Constant Read Abnormal Completion Flag • CH□ Control Output Period Setting • CH□ Control Response Parameter • CH□ Stop Mode Setting • PID Continuation Flag • CH□ Stop Mode Setting • PID Continuation Flag • CH□ Temperature Process Value (PV) Upper Limit Cross Alert • CH□ Temperature Process Value (PV) Lower Limit Cross Alert <ul style="list-style-type: none"> • CH□ Input Range • CH□ Upper Setting Limiter • CH□ Lower Setting Limiter • CH□ Forward/Reverse Action Setting • CH□ Setting Change Rate Limiter • CH□ Sensor Compensation Value Setting • CH□ Primary Delay Digital Filter Setting • CH□ Upper Output Limiter • CH□ Lower Output Limiter • CH□ Output Variation Limiter • CH□ Adjustment Sensitivity (Dead Band) Setting • CH□ AT Bias • CH□ Unused Channel Setting • Transistor Output Monitor ON Delay Time Setting • CH□ MAN Mode Shift Completion Flag • CH□ AUTO/MAN Mode Switching • CH□ MAN Output Setting • Auto Tuning 	Section 5.6

5.2 Installing and Uninstalling the Utility Package

For how to install or uninstall the utility package, refer to "Method of installing the MELSOFT Series" included in the utility package.

5.2.1 Handling precautions

The following explains the precautions on using the Utility package:

(1) For safety

Since Utility package is add-in software for GX Developer, read "Safety Precautions" and the basic operating procedures in the GX Developer Operating Manual.

(2) About installation

GX Configurator-TC is add-in software for GX Developer Version 4 or later. Therefore, GX Configurator-TC must be installed on the personal computer that has already GX Developer Version 4 or later installed.

(3) Screen error of Intelligent function module utility

Insufficient system resource may cause the screen to be displayed inappropriately while using the Intelligent function module utility.

If this occurs, close the Intelligent function module utility, GX Developer (program, comments, etc.), and other applications, and then start GX Developer and Intelligent function module utility again.

(4) To start the Intelligent function module utility

(a) In GX Developer, select "QCPU (Q mode)" for PLC series and specify a project.

If any PLC series other than "QCPU (Q mode)" is selected, or if no project is specified, the Intelligent function module utility will not start.

(b) Multiple Intelligent function module utilities can be started.

However, [Open parameters] and [Save parameters] operations under [Intelligent function module parameter] are allowed for one Intelligent function module utility only. Only the [Monitor/test] operation is allowed for the other utilities.

(5) Switching between two or more Intelligent function module utilities

When two or more Intelligent function module utility screens cannot be displayed side by side, select a screen to be displayed on the top of others using the task bar.



(6) Number of parameters that can be set in GX Configurator-TC

When multiple intelligent function modules are mounted, the number of parameter settings must not exceed the following limit.

When intelligent function modules are installed to:	Maximum number of parameter settings	
	Initial setting	Auto refresh setting
Q00J/Q00/Q01CPU	512	256
Q02/Q02H/Q06H/Q12H/Q25HCPU	512	256
Q02PH/Q06PH/Q12PH/Q25PHCPU	512	256
Q12PRH/Q25PRHCPU	512	256
Q02UCPU	2048	1024
Q03UD/Q04UDH/Q06UDH/Q10UDH/ Q13UDH/Q20UDH/Q26UDH/Q03UDE/ Q04UDEH/Q06UDEH/Q10UDEH/ Q13UDEH/Q20UDEH/Q26UDEHCPU	4096	2048
Q50UDEH/Q100UDEHCPU	Reserved	Reserved
MELSECNET/H remote I/O station	512	256

For example, if multiple intelligent function modules are installed in the MELSECNET/H remote I/O station, configure the settings in GX Configurator so that the number of parameter settings for all the intelligent function modules does not exceed the limit of the MELSECNET/H remote I/O station. Calculate the total number of parameter settings separately for the initial setting and for the auto refresh setting.

The number of parameters that can be set for one module in GX Configurator-TC is as shown below.

Target module	Initial setting	Auto refresh setting
Q64TCTT/Q64TCRT	21 (Fixed)	61 (Max.)
Q64TCTTBW/Q64TCRTBW	21 (Fixed)	73 (Max.)

Example) Counting the number of parameter settings in Auto refresh setting

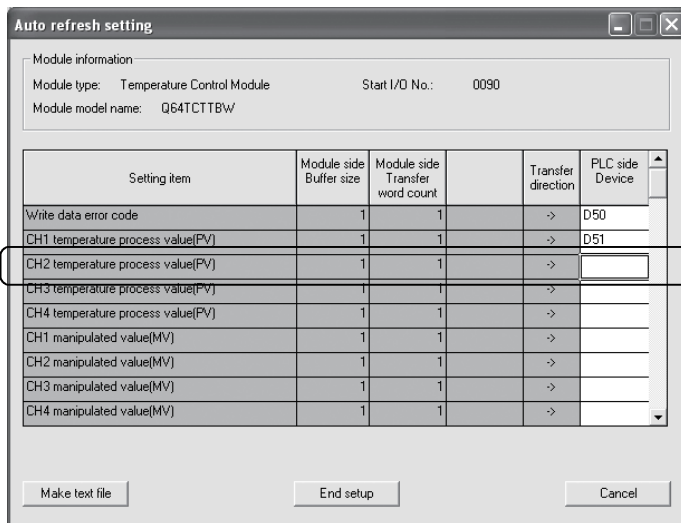

The number of settings in this one line is counted as one setting. The number of settings is not counted by columns. Add up all the setting items in this setting screen, then add them to the total for the other intelligent function modules to get a grand total.

5.2.2 Operating environment

This section explains the operating environment of the personal computer that runs GX Configurator-TC.

Item	Description
Installation (Add-in) target *1	Add-in to GX Developer Version 4 (English version) or later *2
Computer	Windows® -based personal computer
CPU	Refer to the following table "Used operating system and performance required for personal computer".
Required memory	
Hard disk space *3	For installation
	For operation
Display	800 × 600 dots or more resolution *4
Operating system	Microsoft® Windows® 95 Operating System (English version) Microsoft® Windows® 98 Operating System (English version) Microsoft® Windows® Millennium Edition Operating System (English version) Microsoft® Windows NT® Workstation Operating System Version 4.0 (English version) Microsoft® Windows® 2000 Professional Operating System (English version) Microsoft® Windows® XP Professional Operating System (English version) Microsoft® Windows® XP Home Edition Operating System (English version) Microsoft® Windows Vista® Home Basic Operating System (English version) Microsoft® Windows Vista® Home Premium Operating System (English version) Microsoft® Windows Vista® Business Operating System (English version) Microsoft® Windows Vista® Ultimate Operating System (English version) Microsoft® Windows Vista® Enterprise Operating System (English version)

*1: Install GX Configurator-TC in GX Developer Version 4 or higher in the same language.

GX Developer (English version) and GX Configurator-TC (Japanese version) cannot be used in combination, and GX Developer (Japanese version) and GX Configurator-TC (English version) cannot be used in combination.

*2: GX Configurator-TC is not applicable to GX Developer Version 3 or earlier.

*3: At least 15GB is required for Windows Vista® .

*4: Resolution of 1024 X 768 dots or more is recommended for Windows Vista® .

Operating system and performance required for personal computer

Operating system	Performance required for personal computer	
	CPU	Memory
Windows® 95	Pentium® 133MHz or more	32MB or more
Windows® 98	Pentium® 133MHz or more	32MB or more
Windows® Me	Pentium® 150MHz or more	32MB or more
Windows NT® Workstation 4.0	Pentium® 133MHz or more	32MB or more
Windows® 2000 Professional	Pentium® 133MHz or more	64MB or more
Windows® XP Professional (Service Pack1 or more)	Pentium® 300MHz or more	128MB or more
Windows® XP Home Edition (Service Pack1 or more)	Pentium® 300MHz or more	128MB or more
Windows Vista® Home Basic	Pentium® 1GHz or more	1GB or more
Windows Vista® Home Premium	Pentium® 1GHz or more	1GB or more
Windows Vista® Business	Pentium® 1GHz or more	1GB or more
Windows Vista® Ultimate	Pentium® 1GHz or more	1GB or more
Windows Vista® Enterprise	Pentium® 1GHz or more	1GB or more

POINT









- The functions shown below are not available for Windows® XP and Windows Vista® .
If any of the following functions is attempted, this product may not operate normally.
 - Start of application in Windows® compatible mode
 - Fast user switching
 - Remote desktop
 - Large fonts (Details setting of Display Properties)
 Also, 64-bit version Windows® XP and Windows Vista® are not supported.
- Use a USER authorization or higher in Windows Vista® .

5.3 Utility Package Operation

5.3.1 Common utility package operations

(1) Control keys

Special keys that can be used for operations of the utility package and their applications are shown in the table below.

Key	Application
	<p>Cancels the current entry in a cell.</p> <p>Closes the window.</p>
	Moves between controls in the window.
	Used in combination with the mouse operation to select multiple cells for test execution.
	<p>Deletes the character where the cursor is positioned.</p> <p>When a cell is selected, clears all of the setting contents in the cell.</p>
	Deletes the character where the cursor is positioned.
	Moves the cursor.
	Moves the cursor one page up.
	Moves the cursor one page down.
	Completes the entry in the cell.

(2) Data created with the utility package

The following data or files that are created with the utility package can be also handled in GX Developer. Figure 5.1 shows respective data or files are handled in which operation.

<Intelligent function module parameter>

- (a) This represents the data created in Auto refresh setting, and they are stored in an intelligent function module parameter file in a project created by GX Developer.

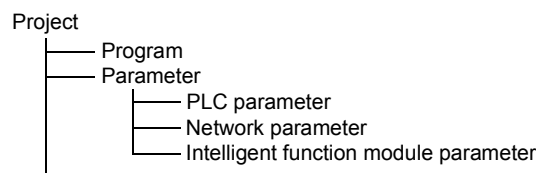

- (b) Steps 1) to 3) shown in Figure 5.1 are performed as follows:

- 1) From GX Developer, select:
[Project] → [Open project] / [Save] / [Save as]
- 2) On the intelligent function module selection screen of the utility, select:
[Intelligent function module parameter] → [Open parameters] / [Save parameters]

3) From GX Developer, select:

[Online] → [Read from PLC] / [Write to PLC] → "Intelligent function module parameters"

Alternatively, from the intelligent function module selection screen of the utility, select:

[Online] → [Read from PLC] / [Write to PLC]

<Text files >

(a) A text file can be created by clicking the **Make text file** button on the initial setting, Auto refresh setting, or Monitor/Test screen. Text files can be utilized to create user documents.

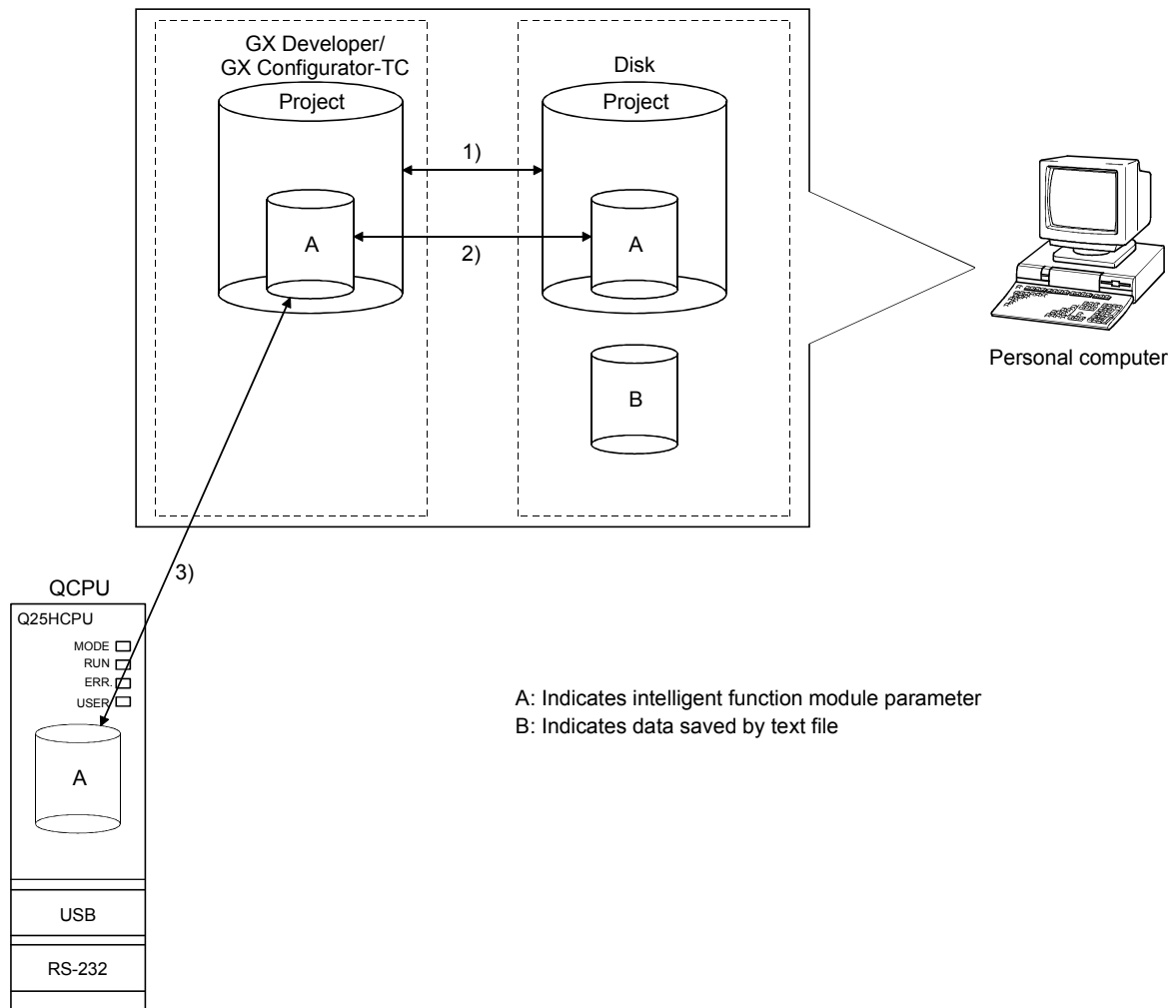
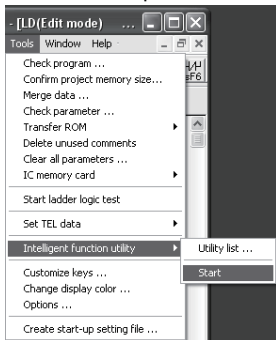

Figure 5.1 Correlation chart for data created with the utility package

5.3.2 Operation overview

GX Developer screen



[Tools] - [Intelligent function utility] - [Start]

Screen for intelligent function module parameter setting module select

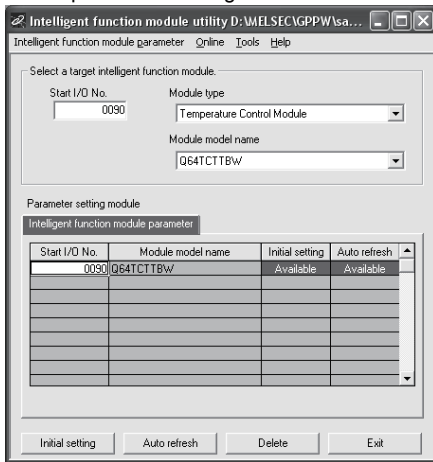

Refer to Section 5.3.3

Enter "Start I/O No.", then select "Module type" and "Module model name".

Initial setting

Auto refresh

Initial setting screen

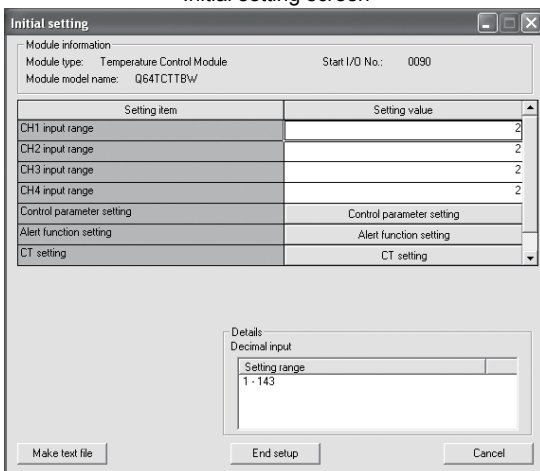

Refer to Section 5.4

Auto refresh setting screen

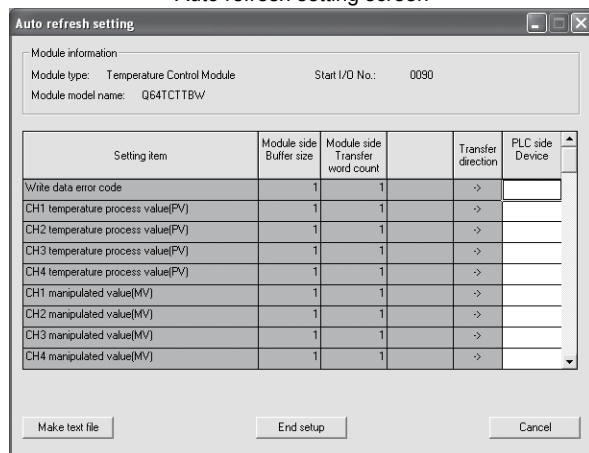

Refer to Section 5.5

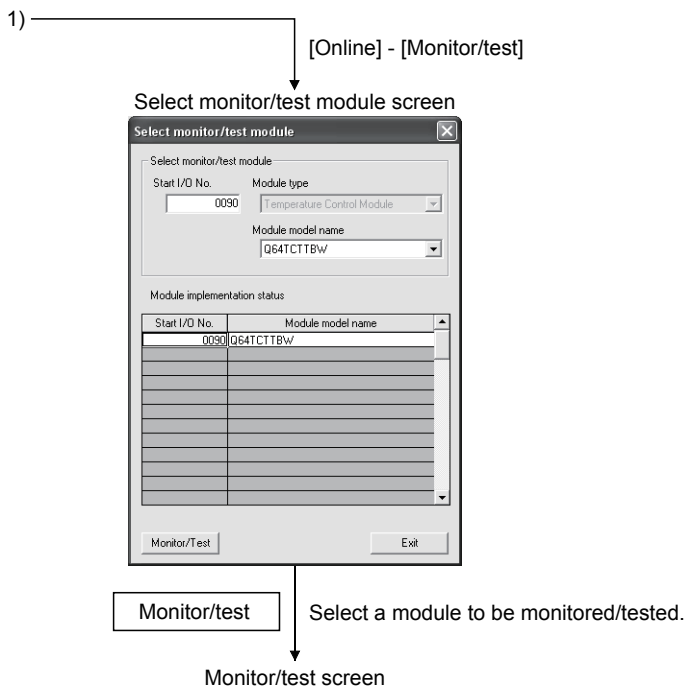

Monitor/Test

Module information

Module type: Temperature Control Module Start I/O No.: 0090

Module model name: Q64TCTTBW

Setting item	Current value	Setting value
Write data error code	0000	
CH1 decimal point position	0	
CH2 decimal point position	0	
CH3 decimal point position	0	
CH4 decimal point position	0	
CH1 Temperature process value(PV)	0	
CH2 Temperature process value(PV)	0	
CH3 Temperature process value(PV)	0	
CH4 Temperature process value(PV)	0	
CH1 manipulated value(MV)	-50	
CH2 manipulated value(MV)	-50	

Flash ROM setting

Write to module Save file Current value display

Read from module Load file Make text file

Details

Monitoring

Cannot execute test

Start monitor Stop monitor Execute test Close

Refer to Section 5.6

5.3.3 Starting the Intelligent function module utility

[Operating procedure]

Intelligent function module utility is started from GX Developer.

[Tools] → [Intelligent function utility] → [Start]

[Setting screen]

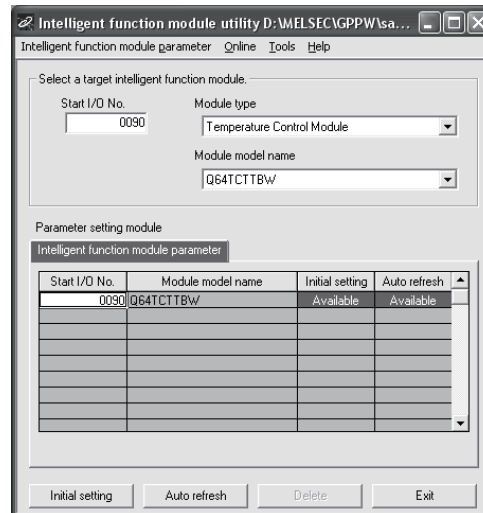

[Explanation of items]

(1) Activation of other screens

Following screens can be displayed from the intelligent function module utility screen.

(a) Initial setting screen

"Start I/O No. *1" → "Module type" → "Module model name" →

Initial setting

(b) Auto refresh setting screen

"Start I/O No. *1" → "Module type" → "Module model name" →

Auto refresh

(c) Select monitor/test module screen

[Online] → [Monitor/Test]

*1: Enter the start I/O No. in hexadecimal.

(2) Command buttons

Delete Deletes the initial settings and auto refresh setting of the selected module.

Exit Closes this screen.

(3) Menu bar

(a) File items

Intelligent function module parameters of the project opened by GX Developer are handled.

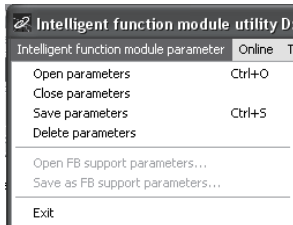

[Open parameters] : Reads a parameter file.

[Close parameters] : Closes the parameter file. If any data are modified, a dialog asking for file saving will appear.

[Save parameters] : Saves the parameter file.

[Delete parameters] : Deletes the parameter file.

[Exit] : Closes this screen.

(b) Online menu

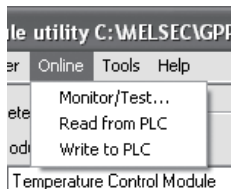

[Monitor/Test] : Activates the select monitor/test module screen.

[Read from PLC] : Reads intelligent function module parameters from the CPU module.

[Write to PLC] : Writes intelligent function module parameters to the CPU module.

POINT

(1) Saving intelligent function module parameters in a file

Since intelligent function module parameters cannot be saved in a file by the project saving operation of GX Developer, save them on the shown module selection screen.

(2) Reading/writing intelligent function module parameters from/to a programmable controller CPU using GX Developer

(a) Intelligent function module parameters can be read from and written into a programmable controller after having been saved in a file.

(b) Set a target programmable controller CPU in GX Developer:

[Online] → [Transfer setup]

(c) When mounting the Q64TC on a remote I/O station, use [Read from PLC] and [Write to PLC] of GX Developer.

(3) Checking the required utility

While the start I/O is displayed on the Intelligent function module utility setting screen, "*" may be displayed for the model name.

This means that the required utility has not been installed or the utility cannot be started from GX Developer.

Check the required utility, selecting [Tools] - [Intelligent function utility] - [Utility list...] in GX Developer.

5.4 Initial Settings

[Purpose of operation]

Make initial setting for operating the temperature control module channel-by-channel.

Refer to Section 5.1 for the initial setting parameter types.

Setting parameters in the Initial setting screen can omit parameter settings with sequence program.

[Startup procedure]

Choose "Start I/O No. *1" → "Module type" → "Module model name" →

Initial setting

*1: Enter the start I/O No. in hexadecimal.

[Setting screen]

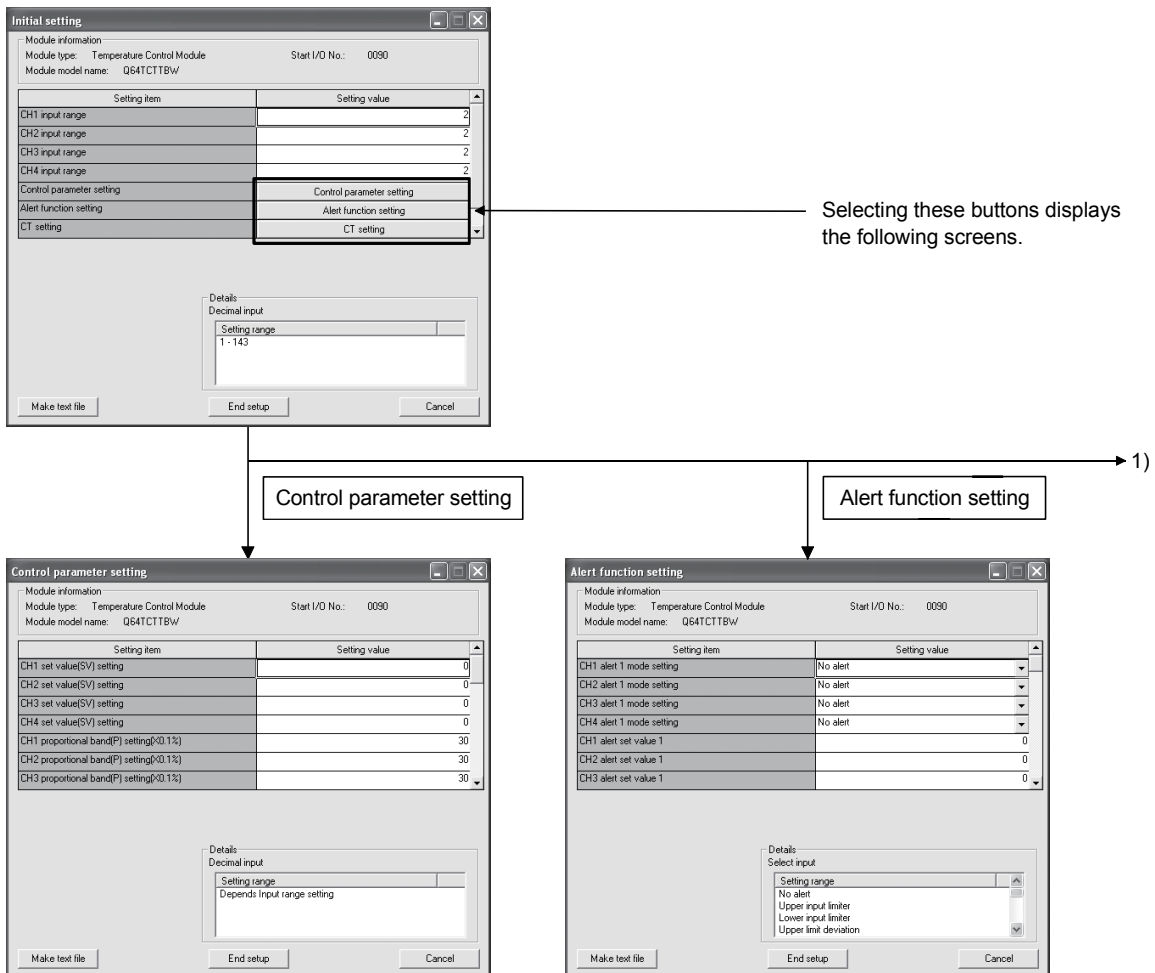

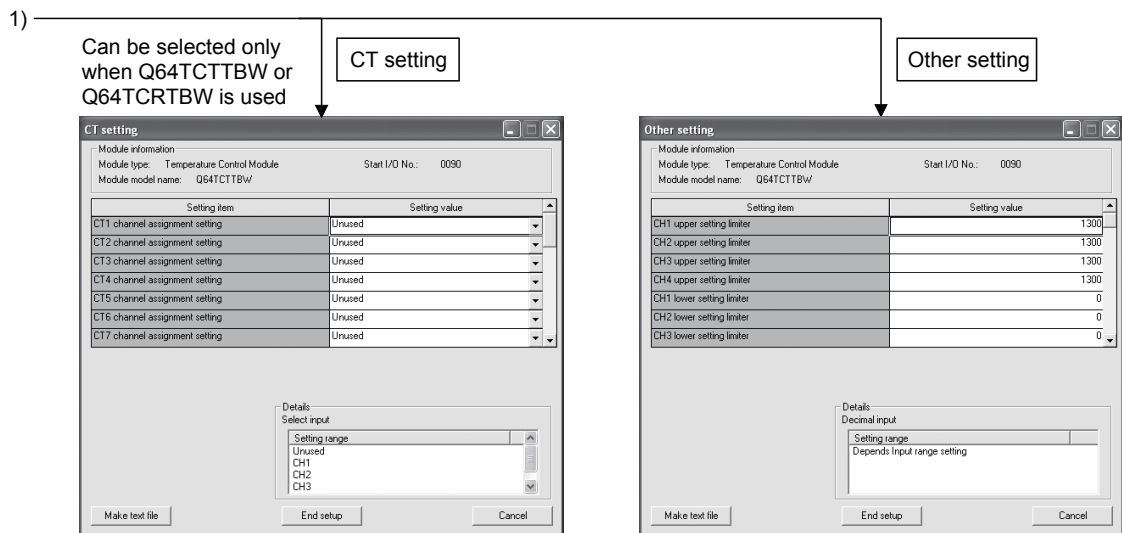

[Explanation of items]

(1) Command buttons

<input type="button" value="Make text file"/>	Creates a file containing the screen data in text file format.
<input type="button" value="End setup"/>	Saves the set data and ends the operation.
<input type="button" value="Cancel"/>	Cancels the set data and ends the operation.

POINT

Initial settings are stored in the intelligent module parameters. After being written to the CPU module, the initial setting is made effective by either (1) or (2).

(1) Cycle the RUN/STOP switch of the CPU module: STOP → RUN → STOP → RUN.

(2) With the RUN/STOP switch set to RUN, turn off and then on the power or reset the CPU module.

If the initialization settings have been written by a sequence program, the initialization settings will be executed during the STOP → RUN of the CPU module. Arrange so that the initial settings written by the sequence program are re-executed during the STOP → RUN of the CPU module.

5.5 Auto Refresh Setting

[Purpose]

Configure the Q64TC buffer memory for auto refresh, for each channel.

Refer to Section 5.1 for the auto refresh setting types.

This auto refresh setting eliminates the need for reading and writing by sequence programs.

[Operating procedure]

"Start I/O No. * 1" → "Module type" → "Module model name" → Auto refresh

*1: Enter the start I/O No. in hexadecimal.

[Setting screen]

Auto refresh setting

Module information

Module type: Temperature Control Module Start I/O No.: 0090

Module model name: Q64TCTTBW

Setting item	Module side Buffer size	Module side Transfer word count	Transfer direction	PLC side Device
Write data error code	1	1	->	<input type="text"/>
CH1 temperature process value(PV)	1	1	->	<input type="text"/>
CH2 temperature process value(PV)	1	1	->	<input type="text"/>
CH3 temperature process value(PV)	1	1	->	<input type="text"/>
CH4 temperature process value(PV)	1	1	->	<input type="text"/>
CH1 manipulated value(MV)	1	1	->	<input type="text"/>
CH2 manipulated value(MV)	1	1	->	<input type="text"/>
CH3 manipulated value(MV)	1	1	->	<input type="text"/>
CH4 manipulated value(MV)	1	1	->	<input type="text"/>

Make text file End setup Cancel

[Explanation of items]

(1) Items

Module side Buffer size : Displays the buffer memory size of the setting item.

Module side Transfer word count : Displays the number of words to be transferred.

Transfer direction : "←" indicates that data are written from the programmable controller CPU to the buffer memory. "→" indicates that data are loaded from the buffer memory to the programmable controller CPU.

PLC side Device : Enter a CPU module side device that is to be automatically refreshed.
Applicable devices are X, Y, M, L, B, T, C, ST, D, W, R, and ZR. When using bit devices, X, Y, M, L or B, set a number that can be divided by 16 points (examples: X10, Y120, M16, etc.).
Also, buffer memory data are stored in a 16-point area, starting from the specified device number. For example, if X10 is entered, data are stored in X10 to X1F.

(2) Command buttons

Creates a file containing the screen data in text file format.

Saves the set data and ends the operation.

Cancels the set data and ends the operation.

POINTS

- The auto refresh settings are stored in an intelligent function module parameter file.
The auto refresh settings become effective by turning the power off and then on or resetting the CPU module after writing the intelligent function module parameters to the CPU module.
- The auto refresh settings cannot be changed from sequence programs. However, processing equivalent to auto refresh can be added using the FROM/TO instruction in the sequence program.

5.6 Monitoring/Test

[Purpose]

Start the buffer memory monitoring/testing and I/O signals monitoring/testing from this screen.

[Operating procedure]

Select monitor/test module screen → "Start I/O No. *1" → "Module type" → "Module model name" → **Monitor/test**

*1: Enter the start I/O No. in hexadecimal.

The screen can also be started from System monitor of GX Developer Version 6 or later.

Refer to the GX Developer Operating Manual for details.

[Setting screen]

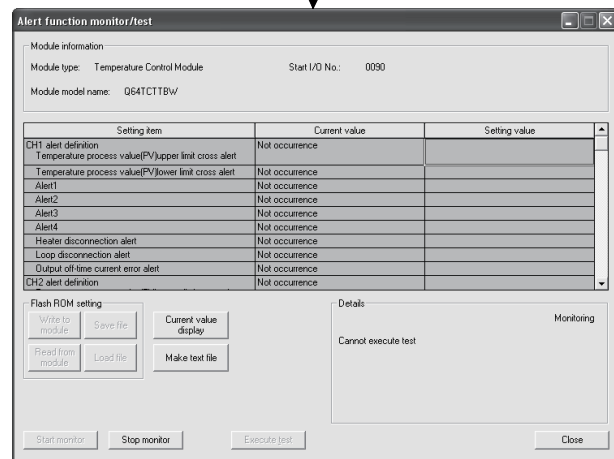
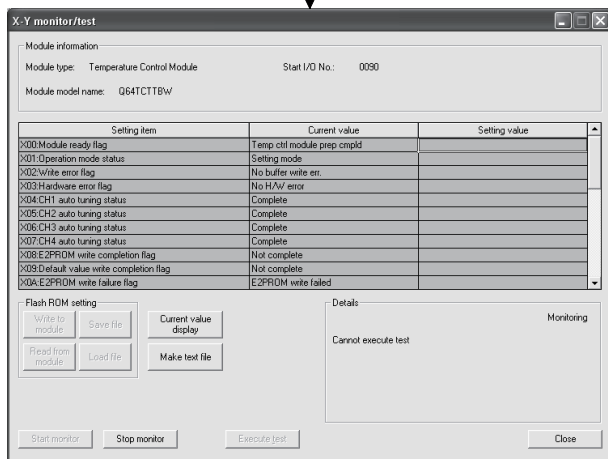
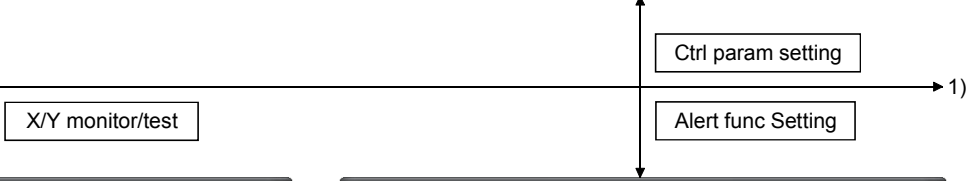
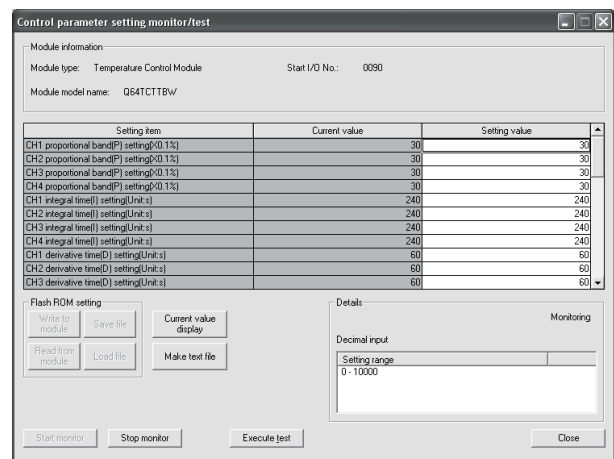
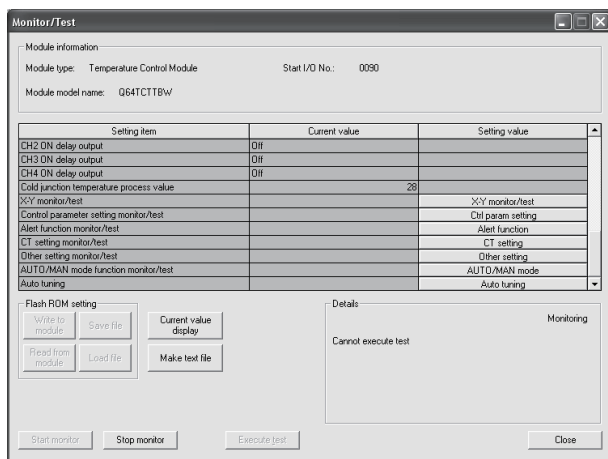

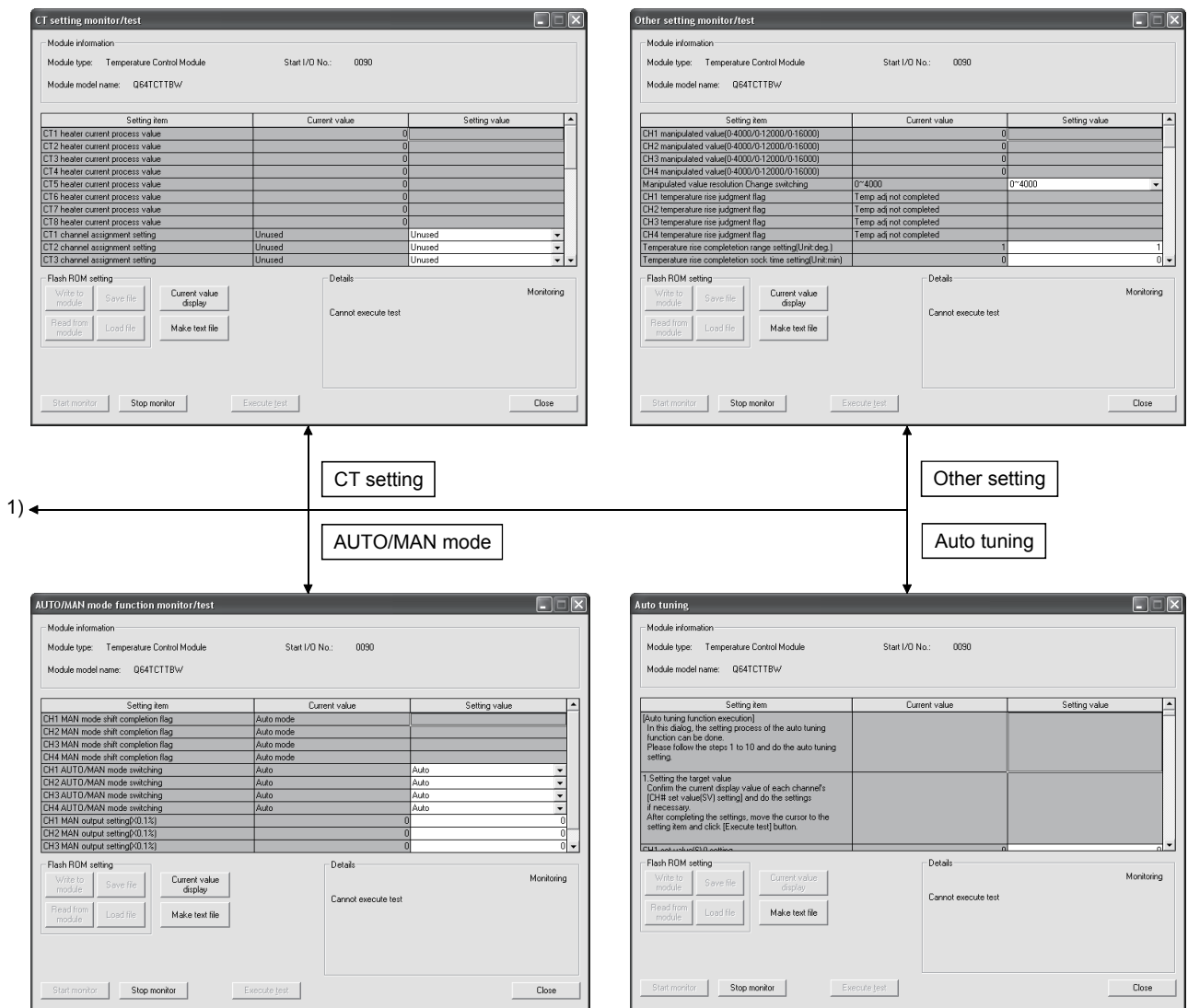

[Explanation of items]

(1) Items

Setting item : Displays I/O signals and buffer memory names.

Current value : Monitors the I/O signal states and present buffer memory values.

Setting value : Enter or select values to be written into the buffer memory for test operation.

(2) Command buttons

Displays the current value of the item selected. (This is used to check the text that cannot be displayed in the current value field. However, in this utility package, all items can be displayed in the display fields).

Creates a file containing the screen data in text file format.

/

Selects whether or not to monitor the current values.

Performs a test on the selected items. To select more than one item, select them while holding down the key.

Closes the screen that is currently open and returns to the previous screen.

(3) Example of using "Execute test"

The following explains the case of writing data to CH1 Set value (SV) setting.

(a) Click and choose the set value field of CH1 Set value setting (SV).

(b) After entering a value, press the key.

Nothing is written to the Q64TC at this point.

(c) Click on the field, of which setting value has been changed in step (b).

(When multiple items have been changed in operation (b), select the setting (value) fields where setting values were changed, while holding down the key. Multiple fields can also be selected by dragging the mouse over them.)

(d) Click to execute the write operation.

Upon completion of writing, the written value appears in the current value field.

6 PROGRAMMING

This chapter describes the programs of the Q64TC.

When applying any of the program examples introduced in this chapter to the actual system, verify the applicability and confirm that no problems will occur in the system control.

6.1 Programming Procedure

Create the programs for running the Q64TC to exercise temperature control in the following procedure.

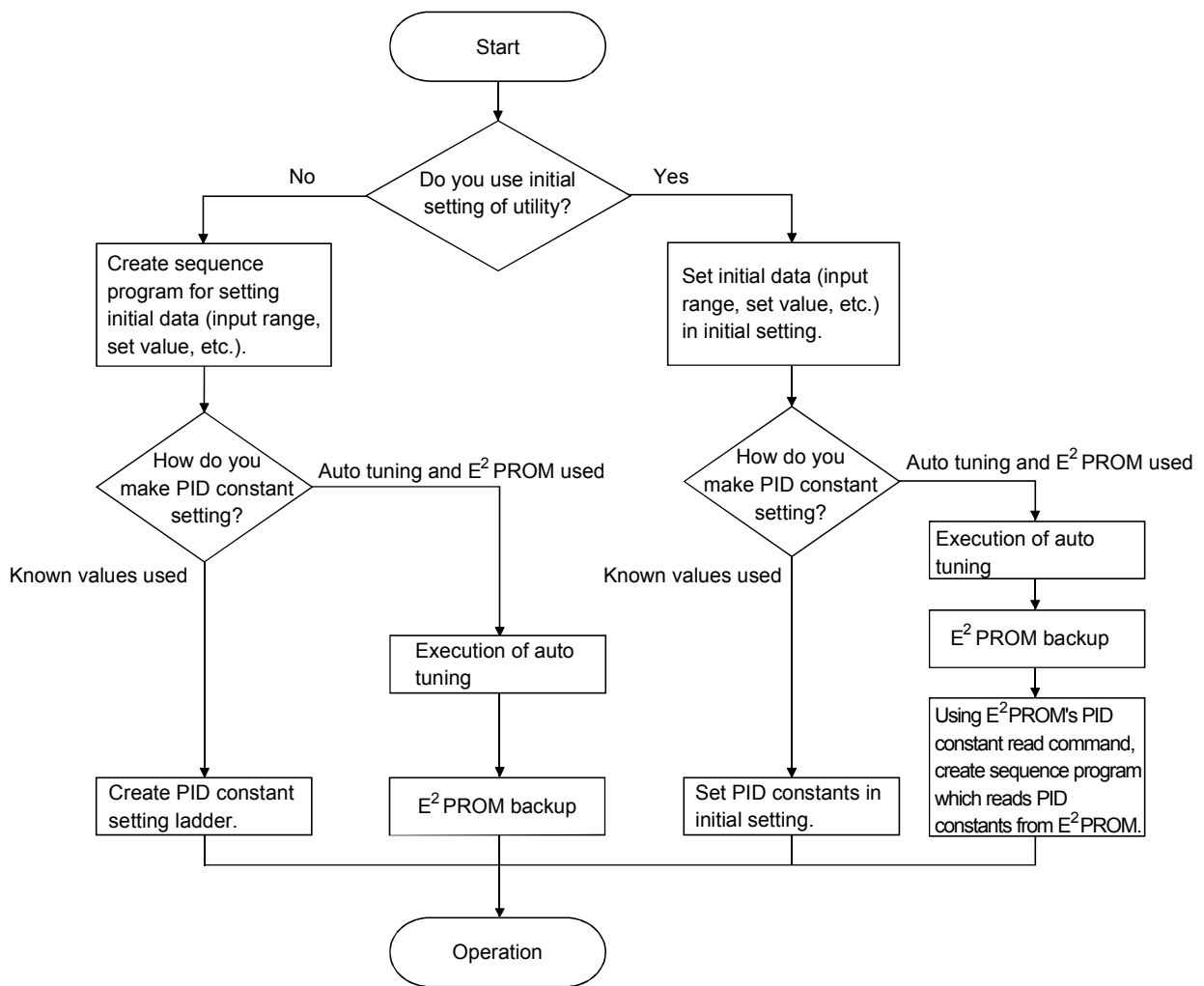

6.2 For Use in Normal System Configuration

System configuration for program explanation

(1) System configuration

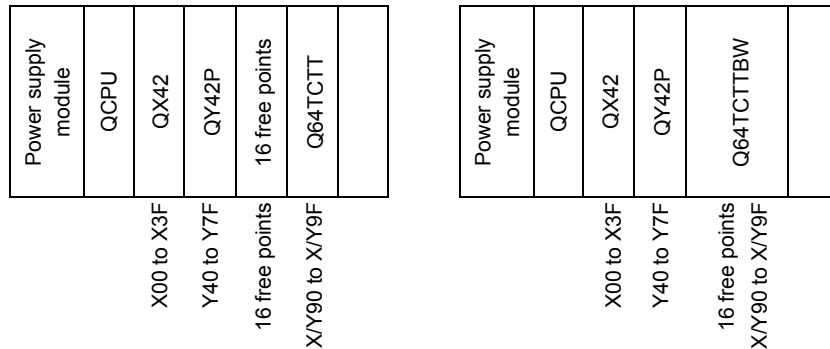

Perform the following intelligent function module switch settings in advance.

- Switch 1 0000H (CH1: CLEAR)
- Switch 2 Empty
- Switch 3 Empty
- Switch 4 Empty
- Switch 5 Empty

(2) Program conditions

The programs are written to read the temperatures measured by the thermocouple (K type) connected to channel 1.

They include write data error code reading and error code resetting programs.

(a) Contents of initial setting

- Used channel..... CH1
- CH1 Set Value Setting (SV)..... 200
- CH1 Alert1 Mode Setting..... UprLmt Input
- CH1 Alert Set Value1 500
- CH1 Upper Setting Limiter 400
- CH1 Lower Setting Limiter 0

(b) Devices used by user

- Set value write command..... X0
- Auto tuning execution command
(when GX Configurator-TC is not used) X1
- E²PROM's PID constant read command
(when GX Configurator-TC is used) X1
- Error code reset command X2
- Operation mode setting command X3
- Temperature detection value output (BCD 4 digits) Y50 to Y5F
- Write data error code storage register D50(D150)
- Read temperature detection value storage register D51

6.2.1 Program example using the utility package

(1) Operation of utility package

(a) Initial setting (Refer to Section 5.4)

- CH1 Input Range "2"
- CH1 Set Value (SV) Setting "200"
- CH1 Alert1 Mode Setting "UprLmt Input"
- CH1 Alert Set Value1 "500"
- CH1 Upper Setting Limiter "400"
- CH1 Lower Setting Limiter "0"
- CH2 Unused Channel Setting "Not Used"
- CH3 Unused Channel Setting "Not Used"
- CH4 Unused Channel Setting "Not Used"

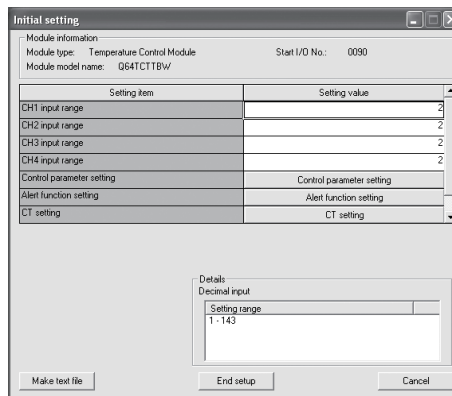

(b) Auto refresh setting (Refer to Section 5.5)

- Write Data Error Code "D50"
- CH1 Temperature Process Value (PV) "D51"

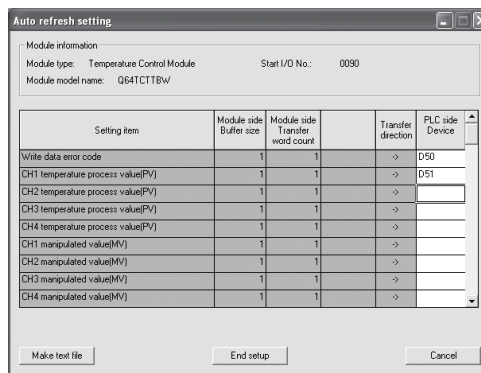

(c) Intelligent function module parameter write (Refer to Section 5.3.3)

Write the parameter values of the intelligent function module to the programmable controller CPU.
 Perform this operation on the parameter setting unit selection screen.

- (d) Execution of auto tuning in monitor/test setting (Refer to Section 5.6)
 Auto tuning is executed in the procedure shown on the screen.
 CH1 Auto Backup "Yes"

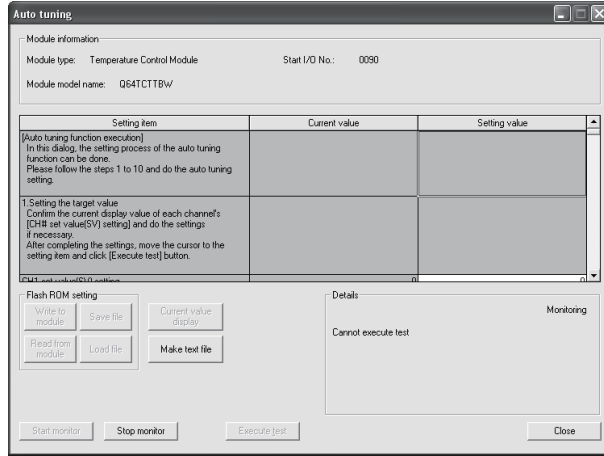

(2) Program example

Turned off in setting mode, turned on in operation mode.

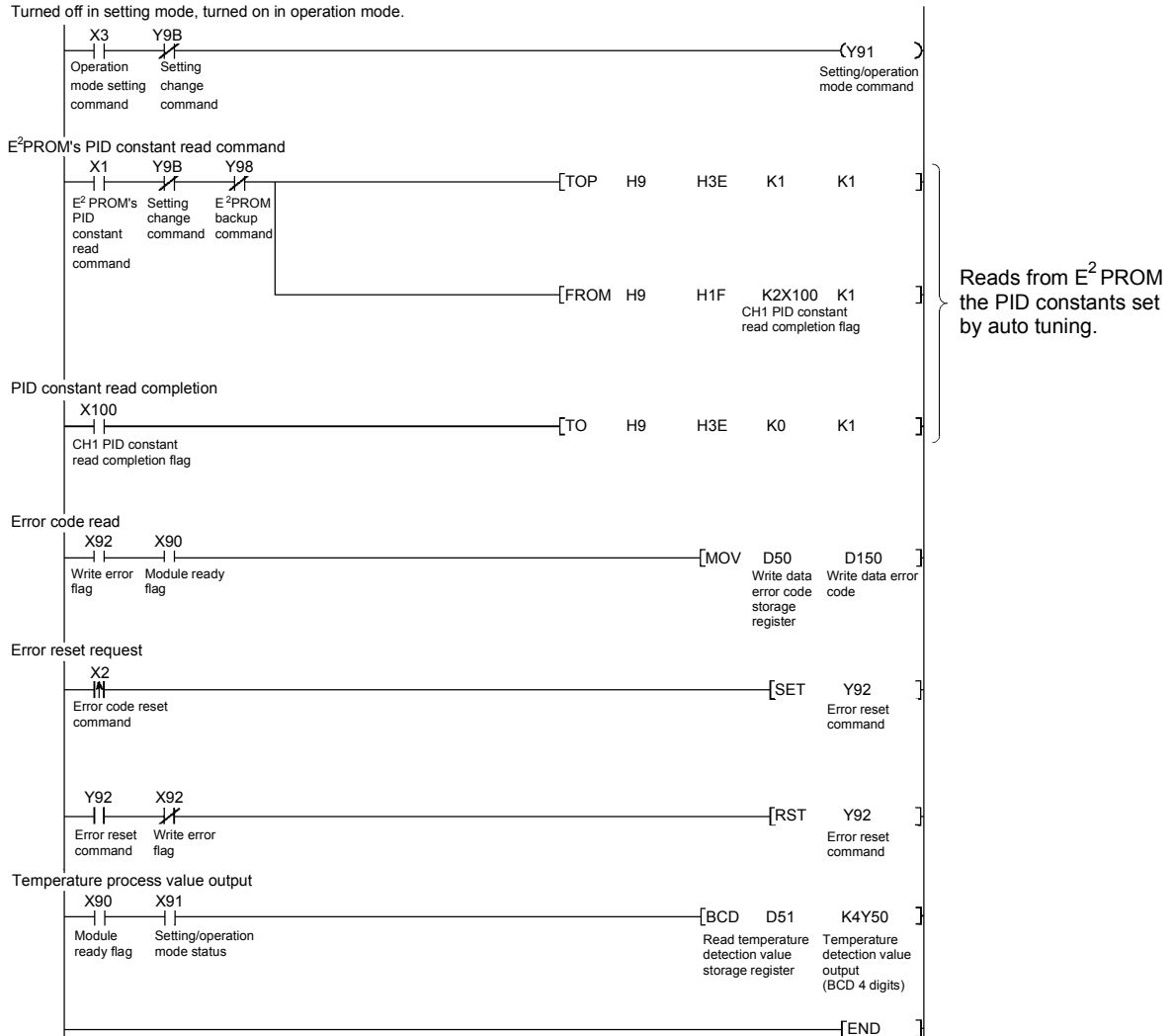

6.2.2 Program example without using the utility package

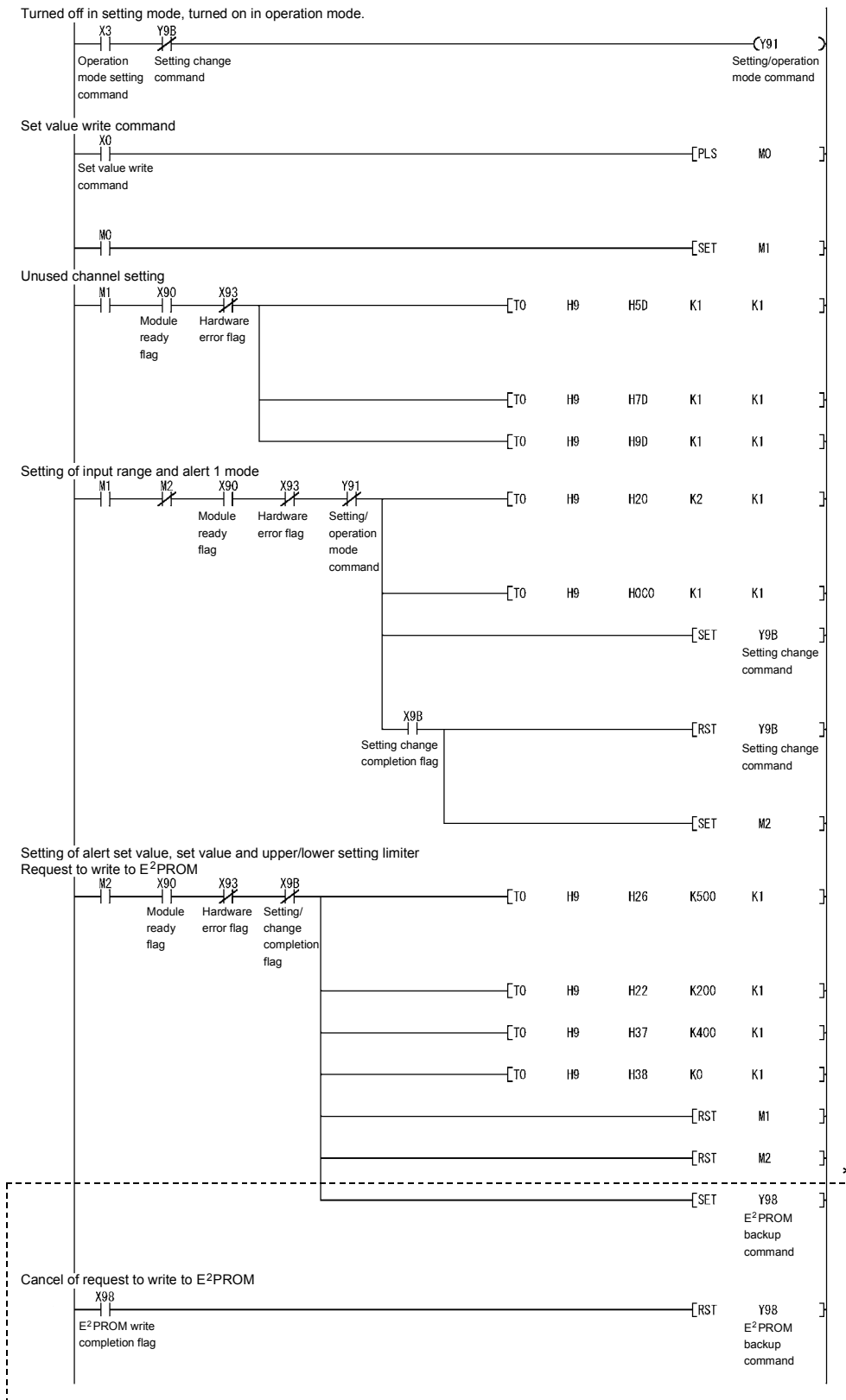

* : Needed when registering the set input range, alert setting, set value and others to E²PROM. Write to E²PROM is not needed when using GX Configurator-TC's initial setting or writing the input range, alert setting, set value and others using sequence program at power-on.

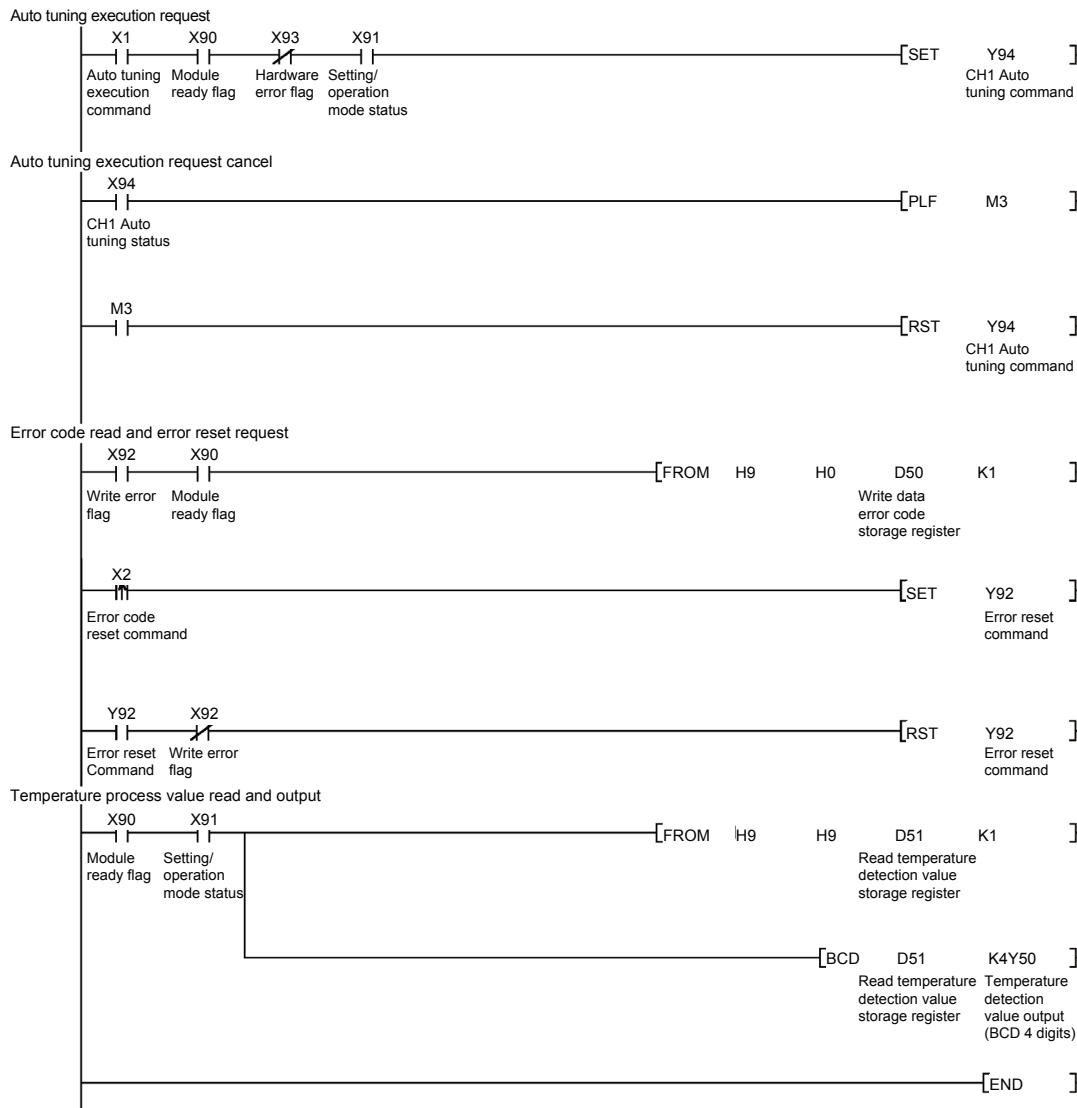

6.3 For Use on Remote I/O Network

System configuration used in the program explanation

(1) System configuration

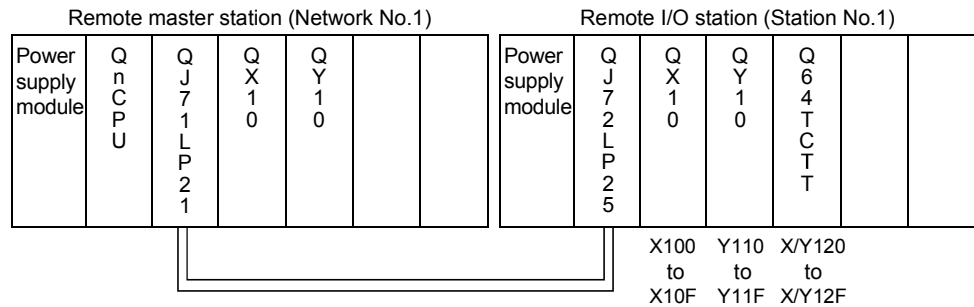

Perform the following intelligent function module switch settings in advance.

- Switch 1 0000H (CH1: CLEAR)
- Switch 2 Empty
- Switch 3 Empty
- Switch 4 Empty
- Switch 5 Empty

(2) Program conditions

The temperature measured by the thermocouple (K type) connected to CH1 is read to the programmable controller CPU of the remote master station. They include write data error code reading and error code resetting programs.

(a) Initial settings

- Used channel.....CH1
- CH1 Set Value Setting (SV).....200
- CH1 Alert1 Mode SettingUprLmt Input
- CH1 Alert Set Value1500
- CH1 Upper Setting Limiter400
- CH1 Lower Setting Limiter0

(b) Devices used by user

- Set value write command.....X20
- Auto turning execution command (when GX Configurator-TC is not used).....X21
- E²PROM's PID constant read command (when GX Configurator-TC is used).....X21
- Error code reset commandX22
- Operation mode setting commandX23
- Temperature detection value output (BCD 4 digits).....Y30 to Y3F
- Write data error code storage register.....D50 (W150)
- Read temperature detection value storage registerD51 (W151)

POINT

For details on the MELSECNET/H remote I/O network, refer to the Q Corresponding MELSECNET/H Network System Reference Manual (Remote I/O Network).

6.3.1 Program example using the utility package

(1) Operating GX Developer

(a) Network parameter setting

- Network type : MNET/H (remote master)
- Head I/O No. : 0000H
- Network No. : 1
- Total number of (slave) stations : 1
- Mode : Online
- Network range assignment :

StationNo.	M station -> R station						M station <- R station					
	Y			Y			X			X		
	Points	Start	End	Points	Start	End	Points	Start	End	Points	Start	End
1	256	0100	01FF	256	0000	00FF	256	0100	01FF	256	0000	00FF

StationNo.	M station -> R station			M station <- R station			M station -> R station			M station <- R station		
	B			B			W			W		
	Points	Start	End	Points	Start	End	Points	Start	End	Points	Start	End
1							256	0000	00FF	256	0100	01FF

• Refresh parameters :

	Dev. name	Link side				PLC side			
		Points	Start	End		Dev. name	Points	Start	End
Transfer SB	SB	512	0000	01FF	↔	SB	512	0000	01FF
Transfer SW	SW	512	0000	01FF	↔	SW	512	0000	01FF
Random cyclic	LB				↔				
Random cyclic	LW				↔				
Transfer1	LB	8192	0000	1FFF	↔	B	8192	0000	1FFF
Transfer2	LW	8192	0000	1FFF	↔	W	8192	0000	1FFF
Transfer3	LX	512	0000	01FF	↔	X	512	0000	01FF
Transfer4	LY	512	0000	01FF	↔	Y	512	0000	01FF
Transfer5					↔				
Transfer6					↔				

(2) Operating the utility package

(a) Initial setting (Refer to Section 5.4)

- CH1 Input Range "2"
- CH1 Set Value (SV) Setting "200"
- CH1 Alert1 Mode Setting "UprLmt Input"
- CH1 Alert Set Value1 "500"
- CH1 Upper Setting Limiter "400"
- CH1 Lower Setting Limiter "0"
- CH2 Unused Channel Setting "Not Used"
- CH3 Unused Channel Setting "Not Used"
- CH4 Unused Channel Setting "Not Used"

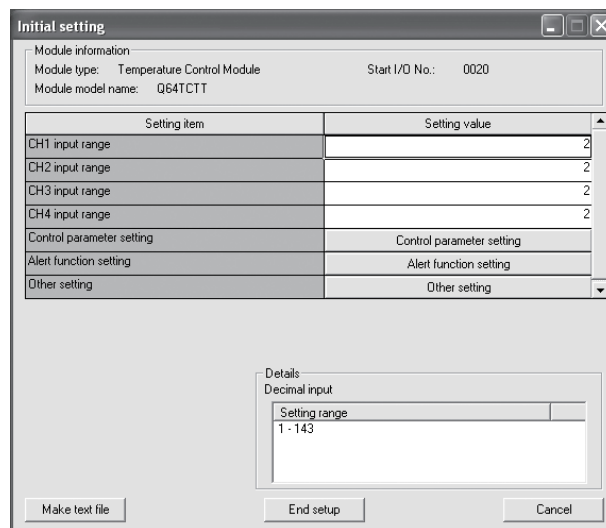

(b) Auto refresh setting (Refer to Section 5.5)

Write Data Error Code....."W150"

CH1 Temperature Process Value (PV)....."W151"

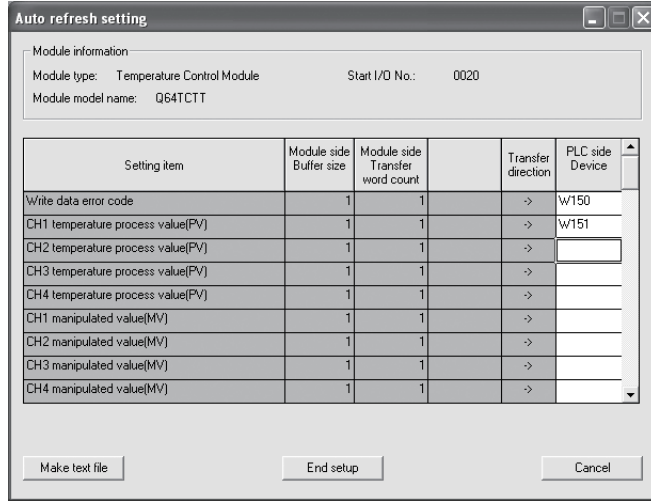

(c) Intelligent function module parameter write (Refer to Section 5.3.3)

The intelligent function module parameters are written to the remote I/O station.

Perform this operation on the parameter setting unit selection screen.

(d) Execution of auto tuning in monitor/test setting (Refer to Section 5.6)

Auto tuning is executed in the procedure shown on the screen.

CH1 Auto Backup "Yes"

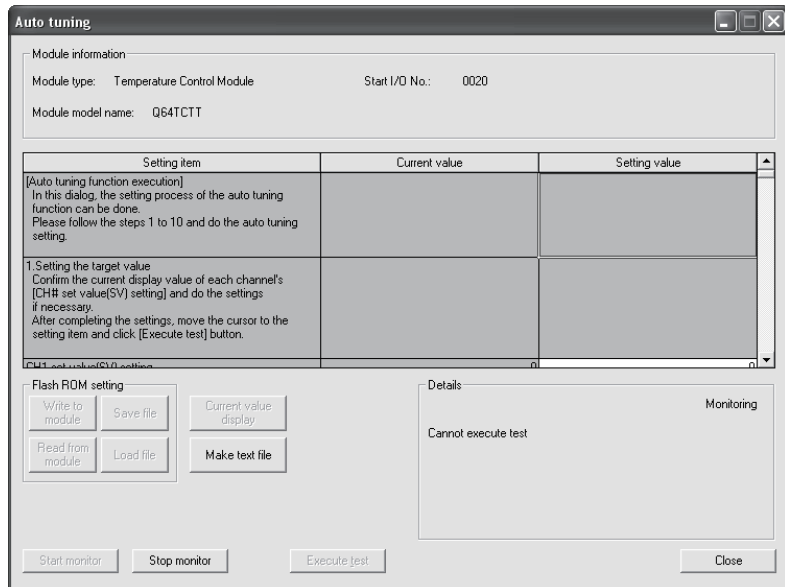

(3) Program example

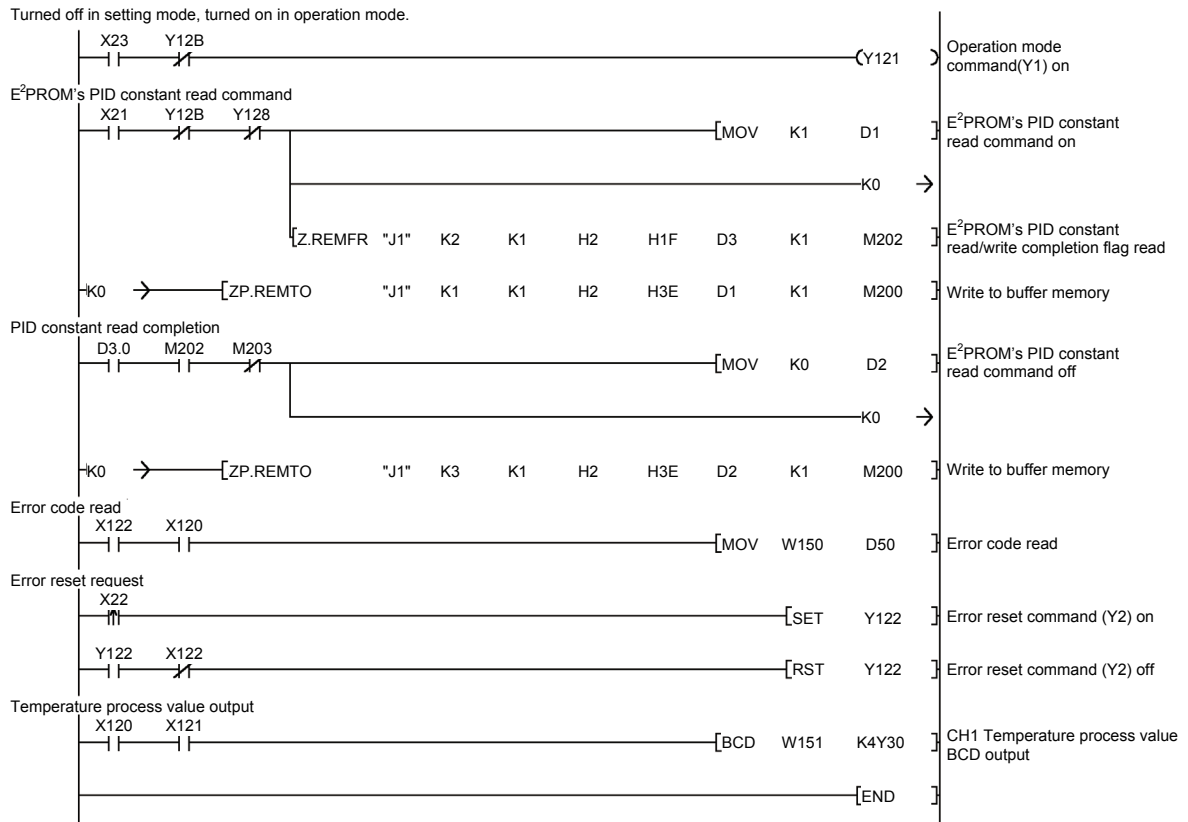

POINT

To write the intelligent function module parameters, set the target remote I/O station from [Online] - [Transfer setup] on GX Developer.

They can be written by:

- Directly connecting GX Developer to the remote I/O station.
- Connecting GX Developer to another device such as a CPU module and passing through the network.

6.3.2 Program example without using the utility package

(1) Operation of GX Developer (Network parameter setting)

- Network type : MNET/H (remote master)
- Head I/O No. : 0000H
- Network No. : 1
- Total number of (slave) stations : 1
- Mode : Online
- Network range assignment :

StationNo.	M station -> R station						M station <- R station					
	Y			Y			X			X		
	Points	Start	End	Points	Start	End	Points	Start	End	Points	Start	End
1	256	0100	01FF	256	0000	00FF	256	0100	01FF	256	0000	00FF

- Refresh parameters :

	Link side					PLC side			
	Dev. name	Points	Start	End		Dev. name	Points	Start	End
Transfer SB	SB	512	0000	01FF	↔	SB	512	0000	01FF
Transfer SW	SW	512	0000	01FF	↔	SW	512	0000	01FF
Random cyclic	LB				↔				
Random cyclic	LW				↔				
Transfer1	LB	8192	0000	1FFF	↔	B	8192	0000	1FFF
Transfer2	LW	8192	0000	1FFF	↔	W	8192	0000	1FFF
Transfer3	LX	512	0000	01FF	↔	X	512	0000	01FF
Transfer4	LY	512	0000	01FF	↔	Y	512	0000	01FF
Transfer5					↔				
Transfer6					↔				

(2) Program example

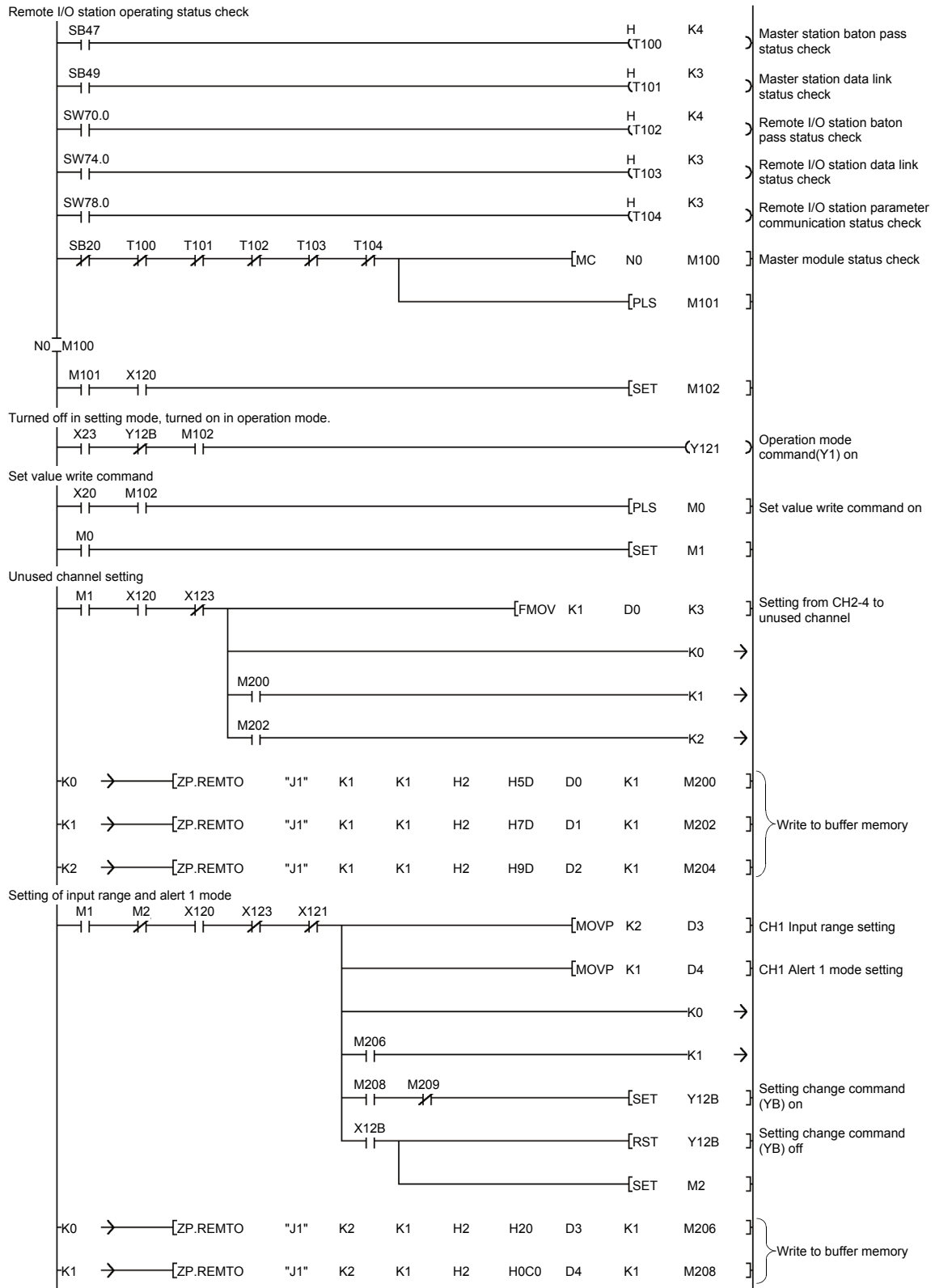

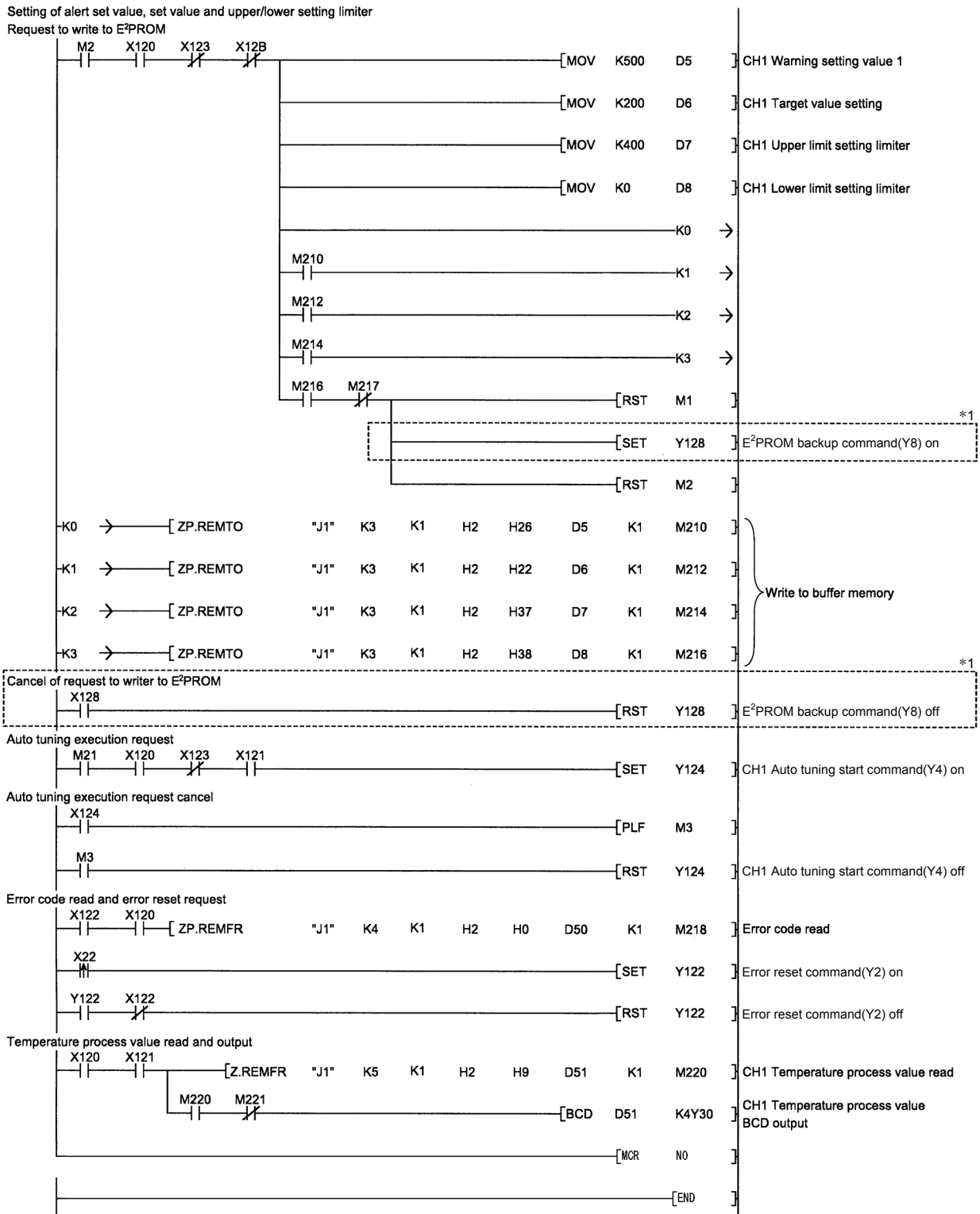

*1: Needed when registering the set input range, alert setting, set value and others to E²PROM.

Write to E²PROM is not needed when using GX Configurator-TC's initial setting or writing the input range, alert setting, set value and others using sequence program at power-on.

7 ONLINE MODULE CHANGE

When changing a module online, carefully read the QCPU User's Manual (Hardware Design, Maintenance and Inspection), Section 12.4.1 "Online module change".

This chapter describes the specifications of an online module change.

- (1) Perform an online module change by operating GX Developer.
- (2) When you want to continue the pre-change operation with the new module after an online module change, save/restore the buffer memory contents.

POINT
<p>(1) Perform an online module change after making sure that the system outside the programmable controller will not malfunction.</p> <p>(2) To prevent an electric shock and malfunction of operating modules, provide means such as switches for powering off each of the external power supply and external devices connected to the module to be replaced online.</p> <p>(3) After the module becomes faulty, the data may not be saved properly. Therefore, prerecord the data to be saved (the whole buffer memory contents that can be written, refer to Section 3.5.1).</p> <p>(4) It is recommended to perform an online module change in the actual system in advance to ensure that it would not affect the other modules by checking the following:</p> <ul style="list-style-type: none">• Means of cutting off the connection to external devices and its configuration are correct.• Switching on/off does not bring any undesirable effect. <p>(5) Do not install/remove the module to/from the base unit, or the terminal block to/from the module more than 50 times after the first use of the product. (IEC 61131-2 compliant) Failure to do so may cause malfunction.</p>

7.1 Online Module Change Conditions

The programmable controller CPU, MELSECNET/H remote I/O module, Q64TC, GX Developer and base unit given below are needed to perform an online module change.

(1) Programmable controller CPU

The Process CPU or Redundant CPU is required.

For precautions for multiple CPU system configuration, refer to the QCPU User's Manual (Multiple CPU System).

For precautions for redundant system configuration, refer to the QnPRHCPU User's Manual (Redundant System).

(2) MELSECNET/H remote I/O module

The module of function version D or later is necessary.

(3) Q64TC

The module of function version C or later is necessary.

(4) GX Developer

GX Developer of Version 7.10L or later is necessary.

GX Developer of Version 8.18U or later is required to perform an online module change on the remote I/O station.

(5) Base unit

1) When the slim type main base unit (Q3□SB) is used, an online module change cannot be performed.

2) When the power supply module unnecessary type extension base unit (Q5□B) is used, online module change cannot be performed for the modules on all the base units connected.

7.2 Online Module Change Operations

The following gives the operations performed for an online module change.

Programmable controller CPU operation ○: Executed ×: Not executed					(User operation) * 3	(Intelligent function module operation)
X/Y refresh	FROM/TO instruction * 1	Device test	GX Configurator			
			Initial setting parameter	Monitor/test		
○	○	○	×	○	<p>(1) Operation stop</p> <p>Turn off all Y signals that were turned on by a sequence program.</p> <p>(2) Dismounting of module</p> <p>Operate GX Developer to start an online module change.</p> <p>Click the [Execution] button of GX Developer to make the module dismountable.</p> <p>Dismount the corresponding module.</p> <p>(3) Mounting of new module</p> <p>Mount a new module.</p> <p>After mounting the module, click the [Execution] button of GX Developer.</p> <p>Operation check before control start</p> <p>(4) Operation check</p> <p>Click the [Cancel] button of GX Developer to leave the online mode.</p> <p>Conduct an operation test on new module using "Device test" of GX Developer or "Monitor/test" of GX Configurator.</p> <p>Operation check completed</p> <p>(5) Resumption of control</p> <p>Operate GX Developer to resume the online module change mode, and click the Execution of button to resume control.</p>	<p>Module is operating as usual.</p> <p>Module stops operating. • RUN LED turns off.</p>
×	×	×	×	×		<p>X/Y refresh resumes and the module starts. • RUN LED turns on. • Default operation (X0 remains off.) (When there are initial setting parameters, operation is performed according to the initial setting parameters at this point.)</p>
○	×	×	○	×		<p>Module operates according to test operation.*2</p>
○	×	○	×	○		<p>X0 (Module ready) turns on. Start is made when X0 turns from off to on. Operation is performed according to the initial setting sequence.*2</p>
○	○	○	×	○		

* 1: Access to the intelligent function module device (U□V□) is included.

* 2: In the absence of the operation marked * 2, the operation of the intelligent function module is the operation performed prior to that.

* 3: The item numbers (1) to (5) correspond to the operation step numbers of "Section 7.3 Online module change procedure".

7.3 Online Module Change Procedure

The online module change procedure is explained separately for the case where GX Configurator-TC was used for initial setting and for the case where a sequence program was used for initial setting.

7.3.1 GX Configurator-TC was used for initial setting

(1) Operation stop

- (a) Turn off the following output signals to stop module operation.

Device No.	Signal name
Yn1	Operation mode command
Yn8	E ² PROM backup start command
Yn9	Default setting registration start command
YnB	Setting change command

POINT

Control may not stop if only Operation mode command (Yn1) is turned off.
 To stop control without fail, set PID continuation flag (buffer memory address: A9H) for 0 (stop) and turn off Operation mode command (Yn1).
 To confirm that control has stopped, make sure that Operation mode status (Xn1) is off.

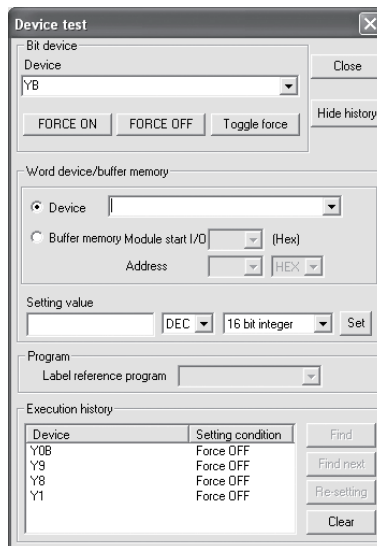

(2) Dismounting of module

- (a) After choosing [Diagnosis] - [Online module change] on GX Developer to enter the "Online module change" mode, double-click the module to be changed online to display the "Online module change" screen.

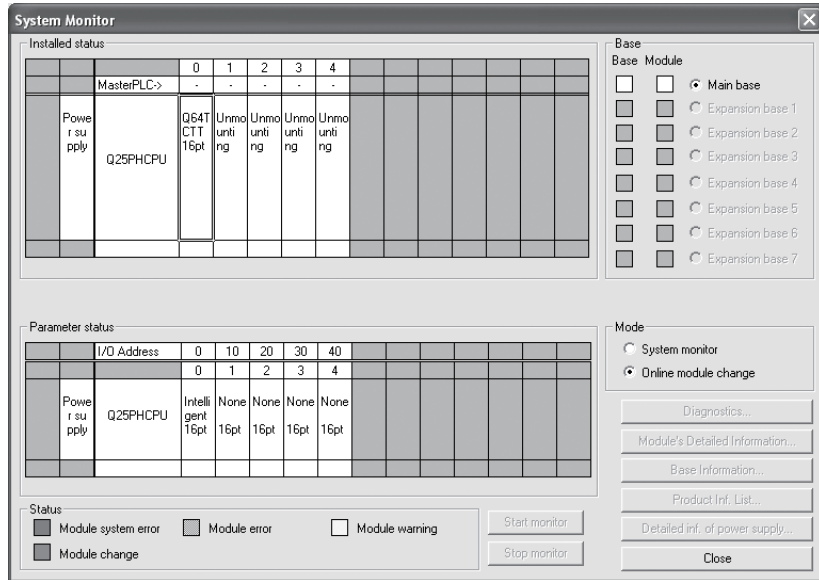

- (b) Click the "Execution" button to enable a module change.

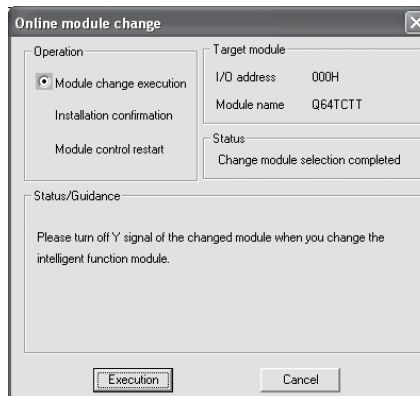

If the following error screen appears, click the "OK" button and perform the operation in (2)(c) and later in this section.

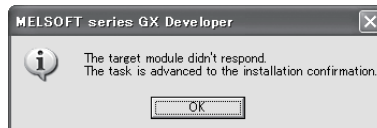

- (c) After confirming that the "RUN" LED of the module has turned off, disconnect the external wiring and dismount the module.

POINT

- (1) If you have removed the wiring together with the terminal block, the temperature process values may vary within the accuracy range due to the error of the specific cold junction temperature compensation resistor. (the Q64TCTT, Q64TCTTBW only)
- (2) Always dismount the module. If mounting confirmation is made without the module being dismounted, the module will not start properly and the "RUN" LED will not be lit.

(3) Mounting of new module

- (a) Mount a new module to the same slot and connect the external wiring.
- (b) After mounting the module, click the [Execution] button and make sure that the "RUN" LED is lit. Module ready flag (Xn0) remains off.

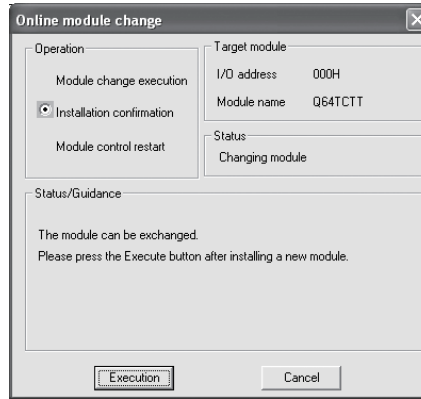

(4) Operation check

- (a) To make an operation check, click the [Cancel] button to cancel control resumption.

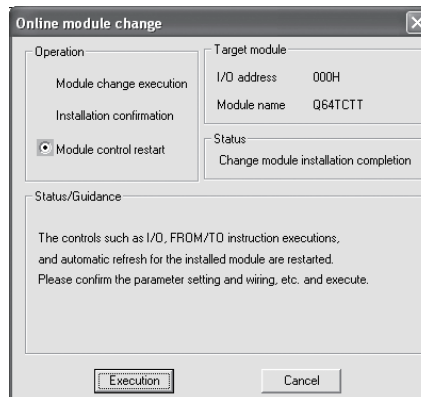

- (b) Click the [OK] button to leave the "Online module change" mode.

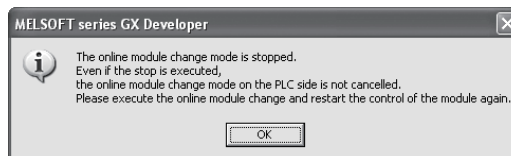

- (c) Click the [Close] button to close the System monitor screen.

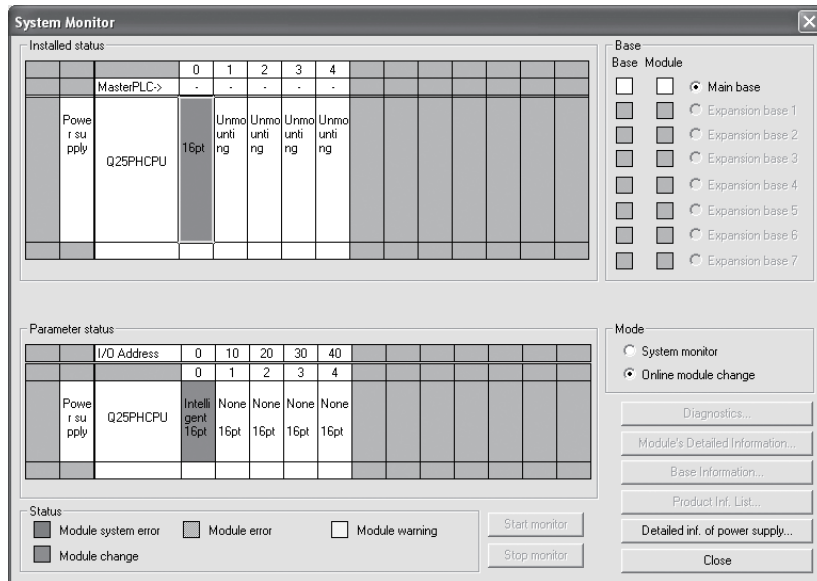

- (d) Before resuming control, check the Q64TC for the following items. If any fault is found, refer to Chapter 8 and take corrective action.
- 1) The RUN LED is on.
 - 2) The ERR. LED is off.
 - 3) The write error flag (Xn2) is off.
 - 4) The hardware error flag (Xn3) is off.

(5) Resumption of control

- (a) After choosing [Diagnosis] - [Online module change] on GX Developer to redisplay the "Online module change" screen, click the [Execution] button to resume control. Module ready flag (Xn0) turns on.

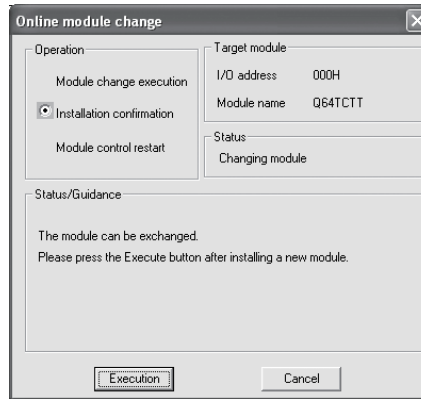

- (b) The "Online module change completed" screen appears.



7.3.2 Sequence program was used for initial setting

(1) Conversion disable

- (a) Turn off the following output signals to stop module operation.

Device No.	Signal name
Yn1	Operation mode command
Yn8	E ² PROM backup start command
Yn9	Default setting registration start command
YnB	Setting change command

POINT

Control may not stop if only Operation mode command (Yn1) is turned off.
 To stop control without fail, set PID continuation flag (buffer memory address: A9H) for 0 (stop) and turn off Operation mode command (Yn1).
 To confirm that control has stopped, make sure that Operation mode status (Xn1) is off.

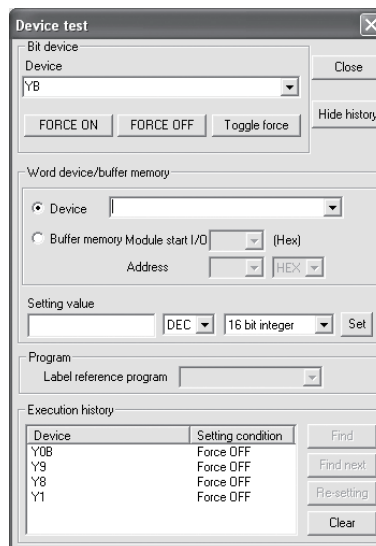

- (b) If the buffer memory contents to be saved are not yet prerecorded, choose "Online" - "Monitor" - "" on GX Developer to monitor the buffer memory and record the values.

POINT

If a CPU continuation error (e.g. SP. UNIT DOWN, UNIT VERIFY ERR.) has occurred due to the fault of the module to be changed, the buffer memory contents cannot be saved.

(2) Dismounting of module

- (a) After choosing [Diagnosis] - [Online module change] on GX Developer to enter the "Online module change" mode, double-click the module to be changed online to display the "Online module change" screen.

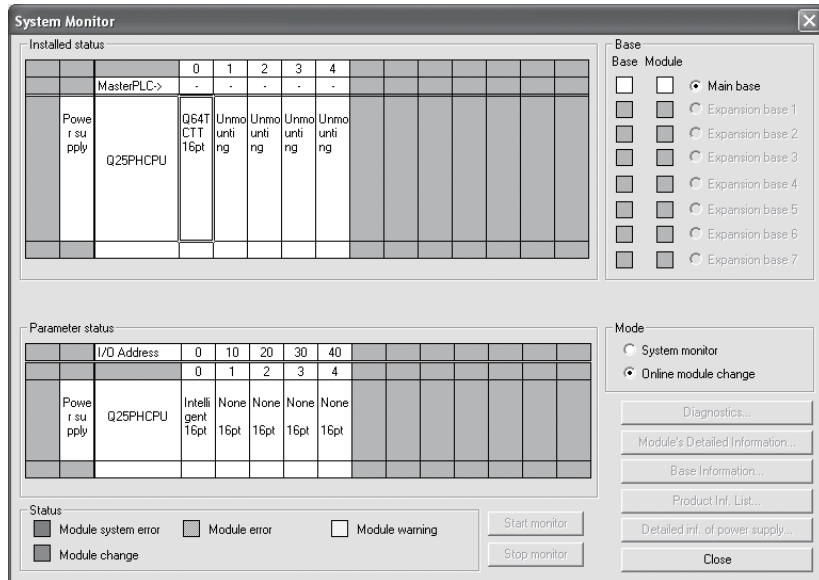

- (b) Click the "Execution" button to enable a module change.

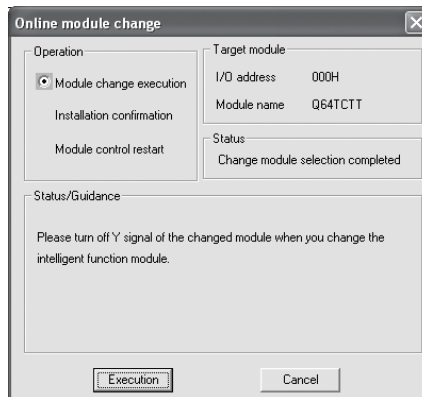

If the following error screen appears, click the "OK" button and perform the operation in (2)(c) and later in this section.

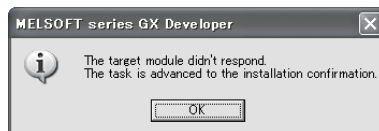

- (c) After confirming that the "RUN" LED of the module has turned off, disconnect the external wiring and dismount the module.

POINT

- (1) If you have removed the wiring together with the terminal block, the temperature process values may vary within the accuracy range due to the error of the specific cold junction temperature compensation resistor. (the Q64TCTT, Q64TCTTBW only)
- (2) Always dismount the module. If mounting confirmation is made without the module being dismounted, the module will not start properly and the "RUN" LED will not be lit.

(3) Mounting of new module

- (a) Mount a new module to the same slot and connect the external wiring.
- (b) After mounting the module, click the [Execution] button and make sure that the "RUN" LED is lit. Module ready flag (Xn0) remains off.

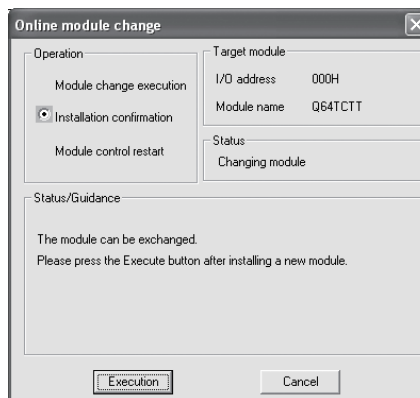

(4) Operation check

- (a) To make an operation check, click the [Cancel] button to cancel control resumption.

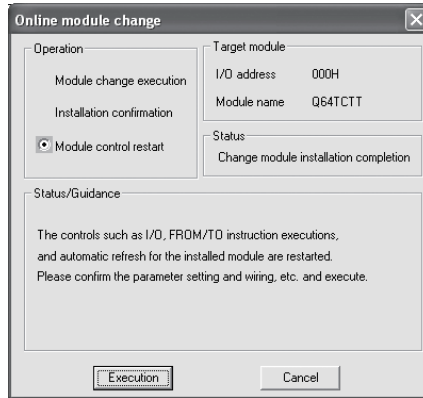

- (b) Click the [OK] button to leave the "Online module change" mode.

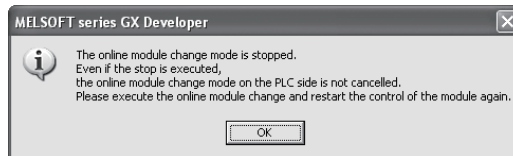

- (c) Click the [Close] button to close the System monitor screen.

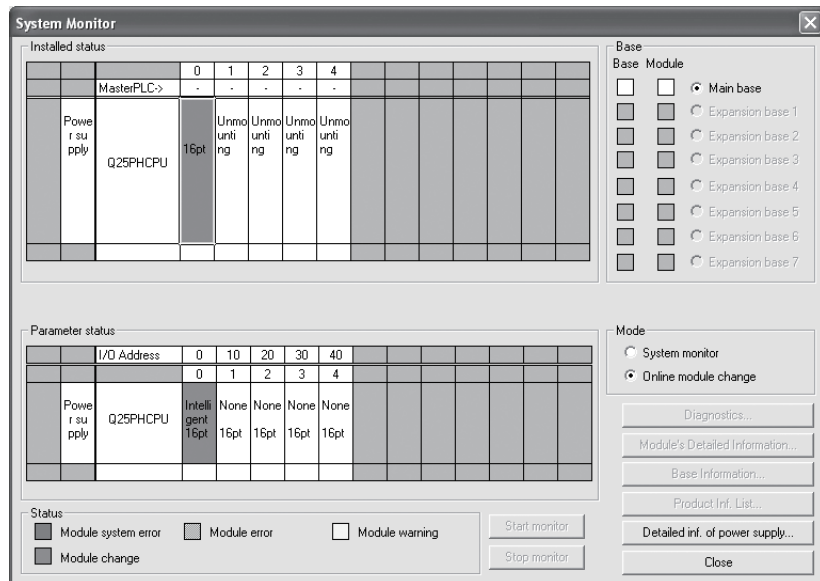

- (d) Choose "Online" - "Debug" - "Device test" on GX Developer to set the prerecorded values to the buffer memory.
- (e) To back up the data on the E²PROM, turn E²PROM backup start command (Yn8) from off to on to write the buffer memory contents to the E²PROM.

- (f) Before resuming control, check the Q64TC for the following items. If any fault is found, refer to Chapter 8 and take corrective action.
- 1) The RUN LED is on.
 - 2) The ERR. LED is off.
 - 3) The write error flag (Xn2) is off.
 - 4) The hardware error flag (Xn3) is off.
- (g) Since the new module is in a default status, it must be initialized by a sequence program after control resumption.
- Before performing initialization, check whether the contents of the initialization program are correct or not.
- 1) Normal system configuration
The sequence program should perform initialization on the leading edge of Module ready flag (Xn0) of the Q64TC.
When control resumption is executed, Module ready flag (Xn0) turns on and initialization is performed. (If the sequence program performs initialization only one scan after RUN, initialization is not performed.)
 - 2) When used on remote I/O network
Insert a user device that will execute initialization at any timing (initialization request signal) into the sequence program. After control resumption, turn on the initialization request signal to perform initialization. (If the sequence program performs initialization only one scan after a data link start of the remote I/O network, initialization is not performed.)

(5) Resumption of control

- (a) After choosing [Diagnosis] - [Online module change] on GX Developer to redisplay the "Online module change" screen, click the [Execution] button to resume control. Module ready flag (Xn0) turns on.

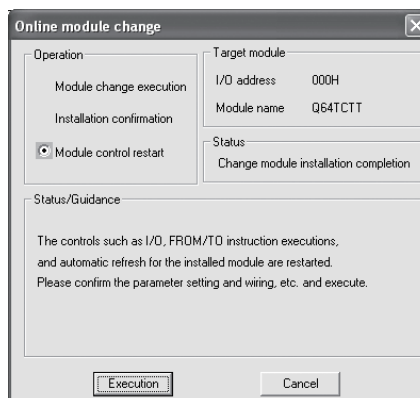

- (b) The "Online module change completed" screen appears.



7.4 Precautions for Online Module Change

The following are the precautions for online module change.

- (1) Always perform an online module change in the correct procedure. A failure to do so can cause a malfunction or failure.
- (2) If you resume control after setting the prerecorded values to the buffer memory of the new module after an online module change, control cannot be resumed in the same control status since the manipulated values (MV) (buffer memory address: D_H to 10_H) are cleared once at the point when control was stopped.
- (3) If an alarm occurred before an online module change, the same alarm will not always occur at the resumption of control. For example, when a standby upper-limit alarm has been set, a standby status will be established and no alarm occur at the resumption of control after an online module change if the alarm occurred before the online module change.

8 TROUBLESHOOTING

8.1 Error Code List

The error code of the Q64TC is stored into address 0 of the buffer memory. The error code is stored into the lower 3 bits of address 0 and the error-detected buffer memory address into the upper 12 bits.

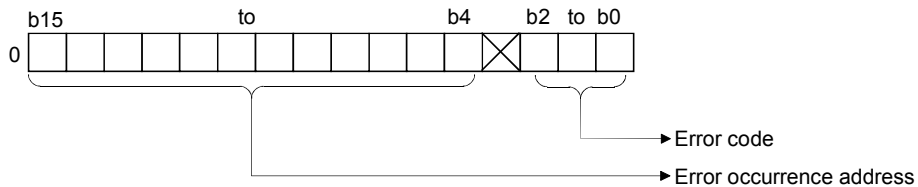

Table 8.1 Error Code List

Error code	Cause	Error-time operation	Corrective action
2	<ul style="list-style-type: none"> A value other than 0 was written to the reserved area. 	<ul style="list-style-type: none"> The written data is held as is. If the data was written to more than one write area, the buffer address where the error was detected first is retained. 	<ul style="list-style-type: none"> Turn on the error reset command (Yn2). Delete the program for performing write to the reserved area.
3	<ul style="list-style-type: none"> Write to the area write-enabled in the setting mode only*1 was performed in the operation mode*2. 	<ul style="list-style-type: none"> The written data is held as is. If the data was written to more than one write area, the lower address of the buffer memory where the error occurred is stored prior to higher addresses. 	<ul style="list-style-type: none"> Make error rest in the following procedure: <ol style="list-style-type: none"> Choose the setting mode. Set a correct value. Turn on the error reset command (Yn2). When changing from the operation mode to the setting mode, make sure that the PID continuation flag (buffer memory address: A9H) is 0 and turn off the operation mode command (Yn1).
4	<ul style="list-style-type: none"> Data outside the setting range was written. 	<ul style="list-style-type: none"> The written data is held as is. If the temperature, time or % setting is beyond the upper or lower limit value, the upper/lower limit value is used to exercise control. If the data outside the range was written to more than one write area, the lower address of the buffer memory where the error occurred is stored prior to higher addresses. 	<ul style="list-style-type: none"> Set data within the range.
5	<ul style="list-style-type: none"> The setting of the upper/lower output limiter or upper/lower setting limiter is illegal. 	<ul style="list-style-type: none"> The written data is held as is. The upper and lower limit values that may be set are used to exercise control. The error occurrence address is stored into the write data error code (buffer memory address: 0H). If the data was written to more than one write area, the lower address of the buffer memory where the error occurred is stored prior to higher addresses. 	<ul style="list-style-type: none"> Make setting so that the upper limit value is greater than the lower limit value.
6	<ul style="list-style-type: none"> The set value was changed during default setting registration. 	<ul style="list-style-type: none"> The written data is ignored. Any set value cannot be changed until error reset is made. If another write error occurs, the buffer memory address data does not change. 	<ul style="list-style-type: none"> After turning on the error reset command (Yn2), change the set value.

*1: The following areas are write-enabled in the setting mode only:

- Input range (buffer memory address: 20H, 40H, 60H, 80H)
- Alert 1 to 4 mode setting (buffer memory address: C0H to C3H, D0H to D3H, E0H to E3H, F0H to F3H)

*2: The system is in the operation mode when:

- Yn1 or Xn1 is on; or
- Yn1 has turned from on to off and the PID continuation flag (buffer memory address: A9H) is 1.

REMARK

- 1) The error code "4" is stored if data outside the setting range is written to the input range area or alert mode setting area in the setting mode.
 If you switch the setting mode to the operation mode without making error reset, the error code changes to "3".
 In this case, perform the error processing of the error code "3".

- 2) The errors have the following priorities.
 If a higher-priority error occurs during occurrence of a lower-priority error, the error code and error occurrence address of the lower-priority error is overwritten by those of the higher-priority error.

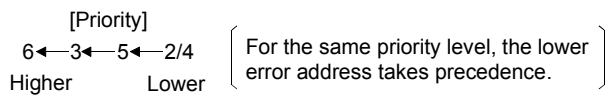

8.2 Processing Performed by the Q64TC at Error Occurrence

The Q64TC performs processing as explained below if an error occurs in the Q64TC/programmable controller CPU or when the programmable controller CPU is switched from RUN to STOP.

Status	Processing			
	CLEAR		HOLD	
	Stop	Continue	Stop	Continue
When programmable controller CPU is switched from RUN to STOP	In accordance with stop mode setting	Operation is continued and external output is provided.	In accordance with stop mode setting	Operation is continued and external output is provided.
At programmable controller CPU stop error occurrence	Operation is stopped and external output is turned off.		In accordance with stop mode setting	Operation is continued and external output is provided.
At the Q64TC write error occurrence	In accordance with operation to be performed at error in Table 8.1 Error code list			
At the Q64TC hardware error occurrence	Depending on hardware error condition			
During programmable controller CPU reset	Module itself becomes inoperative and external output is not provided.			

 <p>WARNING</p>	<ul style="list-style-type: none"> • Be extremely careful when setting the PID continuation flag (buffer memory address: A9H) which controls the external output. • Abnormal output may be provided due to a failure of an output element or its internal circuit. Install an external monitoring circuit for the output signals which may lead to serious accidents.
---	--

8.3 If the RUN LED Has Flickered or Turned Off

Check item	Corrective action
Is 5VDC supplied?	<ul style="list-style-type: none"> • Check the power supply module. • Load the module securely.
Is the sum of current capacities of the modules loaded on the base unit equal to or less than the current capacity of the power supply module?	Make the sum of current capacities of the modules loaded on the base unit equal to or less than the current capacity of the power supply module.
Has a watchdog timer error occurred?	<ul style="list-style-type: none"> • Reset the programmable controller CPU or power it on again. • Change the Q64TC.
Is a module change enabled during an online module change?	Refer to Chapter 7 and take corrective action.

8.4 If the ERR. LED Has Turned On or Flickered

(1) If turned on

Check item	Corrective action
Is the cold junction temperature compensation resistor disconnected?	<ul style="list-style-type: none"> • Connect the cold junction temperature compensation resistor.
—	<ul style="list-style-type: none"> • The Q64TC hardware fault. Please consult your sales representative.

(2) If flickered

Check item	Corrective action
Has a write data error occurred?	<ul style="list-style-type: none"> • Check the error code list in Section 8.1 and correct the sequence program.

8.5 If the ALM LED Has Turned On or Flickered

(1) If turned on

Check item	Corrective action
Has the alert occurrence flag (XnC to XnF) turned on?	<ul style="list-style-type: none"> • Check the alert definition (buffer memory address: 5H to 8H) and take action for the alert that occurred.

(2) If flickered

Check item	Corrective action
Is the process value beyond the measured temperature range specified for the input range?	<ul style="list-style-type: none"> • Change the input range setting to the operating temperature range setting.
Is there any channel where a thermocouple is not connected?	<ul style="list-style-type: none"> • Set the channel where a thermocouple is not connected as unused to the unused channel setting (buffer memory address: 3DH, 5DH, 7DH, 9DH).
Has a loop disconnection been detected?	<ul style="list-style-type: none"> • Check for a load disconnection, external operation device fault, sensor disconnector or the like.

8.6 If the Module Ready Flag (Xn0) Does Not Turn On

Check item	Corrective action
Has a watchdog timer error occurred?	<ul style="list-style-type: none"> • Reset the programmable controller CPU or power it on again. • Change the Q64TC.
Has an error occurred in the programmable controller?	<ul style="list-style-type: none"> • Refer to the used programmable controller CPU User's Manual and take corrective action.

8.7 If the Write Error Flag (Xn2) Has Turned On

Check item	Corrective action
Has a write data error occurred?	<ul style="list-style-type: none"> • Check the error code list in Section 8.1 and correct the sequence program.

8.8 If the Hardware Error Flag (Xn3) Has Turned On

Check item	Corrective action
Is the cold junction temperature compensation resistor disconnected?	<ul style="list-style-type: none"> • Connect the cold junction temperature compensation resistor.
—	<ul style="list-style-type: none"> • The Q64TC hardware fault. Please consult your sales representative.

8.9 If the Auto Tuning Does Not Start (If the Auto Tuning Status (Xn4 to Xn7) Does Not Turn On)

Check item	Corrective action
Are start conditions for auto tuning met?	<ul style="list-style-type: none"> • Check whether the all conditions are met with referring to Section 3.2.1 (2) (a).
Has auto tuning been completed abnormally?	<ul style="list-style-type: none"> • Check whether the auto tuning has completed abnormally with referring to Section 3.2.1 (2) (d).

8.10 If the Auto Tuning Is Not Completed (If the Auto Tuning Status (Xn4 to Xn7) Remains On and Does Not Turn Off)

Check item	Corrective action
Is the E ² PROM's PID constant read/write completion flag (buffer memory address: 1FH) set to 1 (on)?	<ul style="list-style-type: none"> Set 0 (off) to the Automatic backup setting after auto tuning of PID constants (buffer memory address: 3FH, 5FH, 7FH, 9FH), and turn off the E²PROM's PID constant read/write completion flag (buffer memory address: 1FH).
Is the E ² PROM's PID constant read command (buffer memory address: 3EH, 5EH, 7EH, 9EH) set to 1 (With command)?	<ul style="list-style-type: none"> Set the E²PROM's PID constant read command (buffer memory address: 3EH, 5EH, 7EH, 9EH) to 0 (Without command).
Is the set value (SV) set correctly? (Does the manipulated value (MV) remain 0 % since the set value (SV) is small?)	<ul style="list-style-type: none"> Set arbitrary control value to the set value (SV).

8.11 If the Alert Occurrence Flag (XnC to XnF) Has Turned On

Check item	Corrective action
Is the measured temperature error/alert set value beyond the range?	<ul style="list-style-type: none"> Check the alert definition (buffer memory address: 5H to 8H) and take action for the alert that occurred.
Is a disconnection detected?	

8.12 Checking the Q64TC Status by System Monitoring of GX Developer

Choosing the detailed information of the Q64TC in system monitoring of GX Developer allows you to check the error codes and LED lit-up states.

(1) Operating GX Developer

[Diagnosis] → [System monitor] → select the Q64TC to check its status

→ **Module Detailed Information**

(2) Module Detail Information

(a) Checking the function version

The function version of the Q64TC is displayed in the product information field.

050710000000000-C
└─── Function version

(b) Checking the error code

An error code stored in lower bits 0 to 2 in buffer memory address 0 (Un\G0) of the Q64TC is displayed in Present Error field.

(When the **Error History** button is pressed, the contents displayed in the Present Error field are displayed in the No. 1 field.)

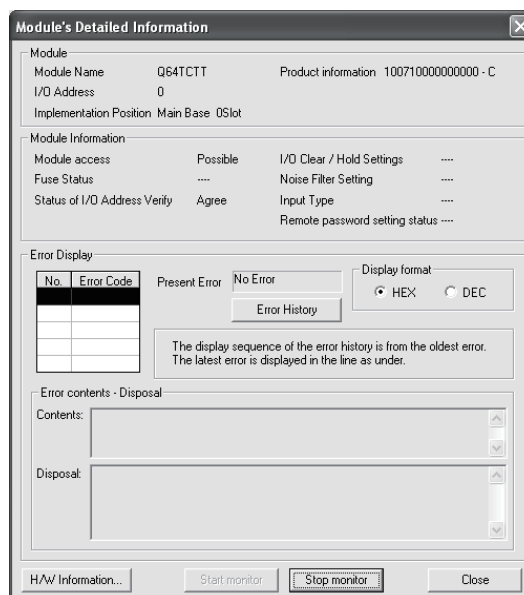

(3) H/W Information (When using GX Developer Version 6 or later)

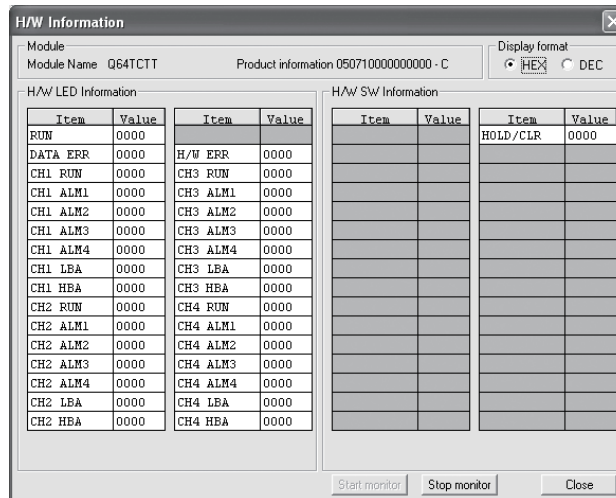

(a) Hardware LED information

The hardware LED information gives the following information.

Item	Condition on which value turns to 1	Item	Condition on which value turns to 1
RUN	Same as the one of the actual RUN LED	—	—
DATA ERR	At write data error occurrence	H/W ERR	At hardware error occurrence
CH1 RUN	When CH1 PID control is exercised	CH3 RUN	When CH3 PID control is exercised
CH1 ALM1	When CH1 Alert1 is on	CH3 ALM1	When CH3 Alert1 is on
CH1 ALM2	When CH1 Alert2 is on	CH3 ALM2	When CH3 Alert2 is on
CH1 ALM3	When CH1 Alert3 is on	CH3 ALM3	When CH3 Alert3 is on
CH1 ALM4	When CH1 Alert4 is on	CH3 ALM4	When CH3 Alert4 is on
CH1 LBA	When CH1 Loop disconnection is detected	CH3 LBA	When CH3 Loop disconnection is detected
CH1 HBA *	When CH1 Heater disconnection is detected	CH3 HBA *	When CH3 Heater disconnection is detected
CH2 RUN	When CH2 PID control is exercised	CH4 RUN	When CH4 PID control is exercised
CH2 ALM1	When CH2 Alert1 is on	CH4 ALM1	When CH4 Alert1 is on
CH2 ALM2	When CH2 Alert2 is on	CH4 ALM2	When CH4 Alert2 is on
CH2 ALM3	When CH2 Alert3 is on	CH4 ALM3	When CH4 Alert3 is on
CH2 ALM4	When CH2 Alert4 is on	CH4 ALM4	When CH4 Alert4 is on
CH2 LBA	When CH2 Loop disconnection is detected	CH4 LBA	When CH4 Loop disconnection is detected
CH2 HBA *	When CH2 Heater disconnection is detected	CH4 HBA *	When CH4 Heater disconnection is detected

*: Only when the Q64TCTTBW/Q64TCRTBW is used

(b) Hardware switch information

Shows the intelligent function module switch 1 setting states.

(4) H/W Information (When using GX Developer Version 5 or earlier)

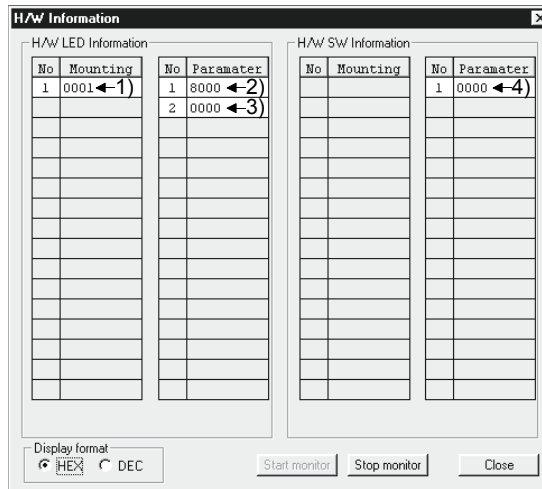

1) Actual LED information

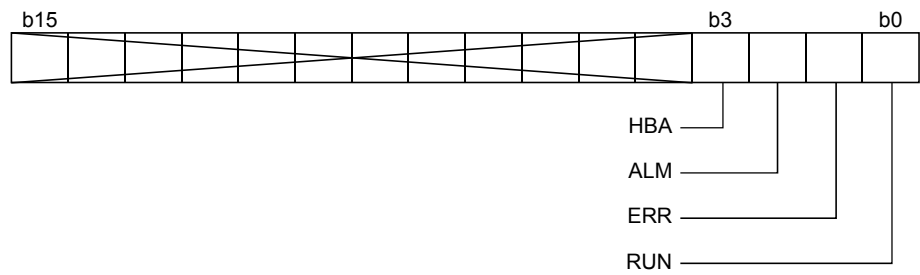

2) LED1 information

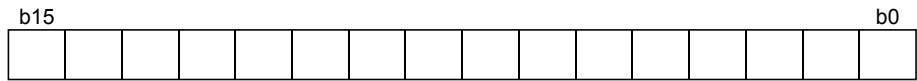

bit	Condition on which bit turns on	bit	Condition on which bit turns on
b0	When CH2 Heater disconnection is detected*	b8	When CH1 Loop disconnection is detected
b1	When CH2 Loop disconnection is detected	b9	When CH1 Alert4 is on
b2	When CH2 Alert4 is on	b10	When CH1 Alert3 is on
b3	When CH2 Alert3 is on	b11	When CH1 Alert2 is on
b4	When CH2 Alert2 is on	b12	When CH1 Alert1 is on
b5	When CH2 Alert1 is on	b13	When CH1 PID control is exercised
b6	When CH2 PID control is exercised	b14	At write data error occurrence
b7	When CH1 Heater disconnection is detected*	b15	Same as the one of the actual RUN LED

*: Only when the Q64TCTTBW/Q64TCRTBW is used

3) LED2 information



bit	Condition on which bit turns on	bit	Condition on which bit turns on
b0	When CH4 Heater disconnection is detected*	b8	When CH3 Loop disconnection is detected
b1	When CH4 Loop disconnection is detected	b9	When CH3 Alert 4 is on
b2	When CH4 Alert4 is on	b10	When CH3 Alert3 is on
b3	When CH4 Alert3 is on	b11	When CH3 Alert2 is on
b4	When CH4 Alert2 is on	b12	When CH3 Alert1 is on
b5	When CH4 Alert1 is on	b13	When CH3 PID control is exercised
b6	When CH4 PID control is exercised	b14	At hardware error occurrence
b7	When CH3 Heater disconnection is detected*	b15	Unused

*: Only when the Q64TCTTBW/Q64TCRTBW is used

4) Switch information

Shows the intelligent function module switch 1 setting states.

APPENDIX

Appendix 1 External Dimensions

(1) Q64TCTT

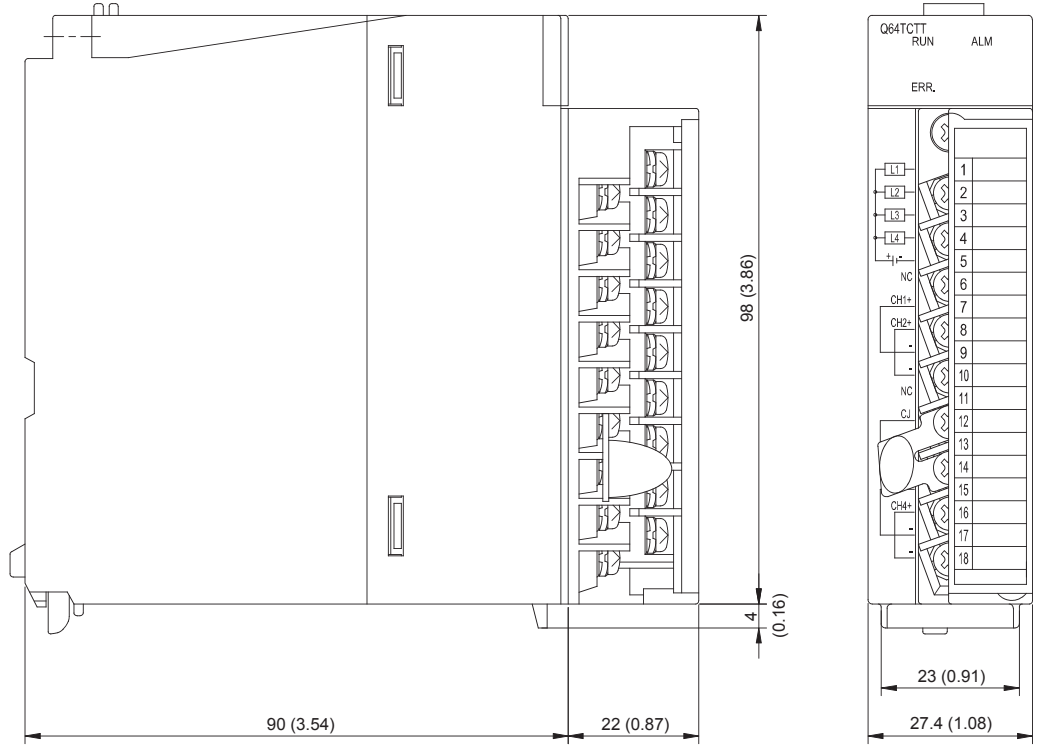

Unit: mm (in.)

(2) Q64TCTTBW

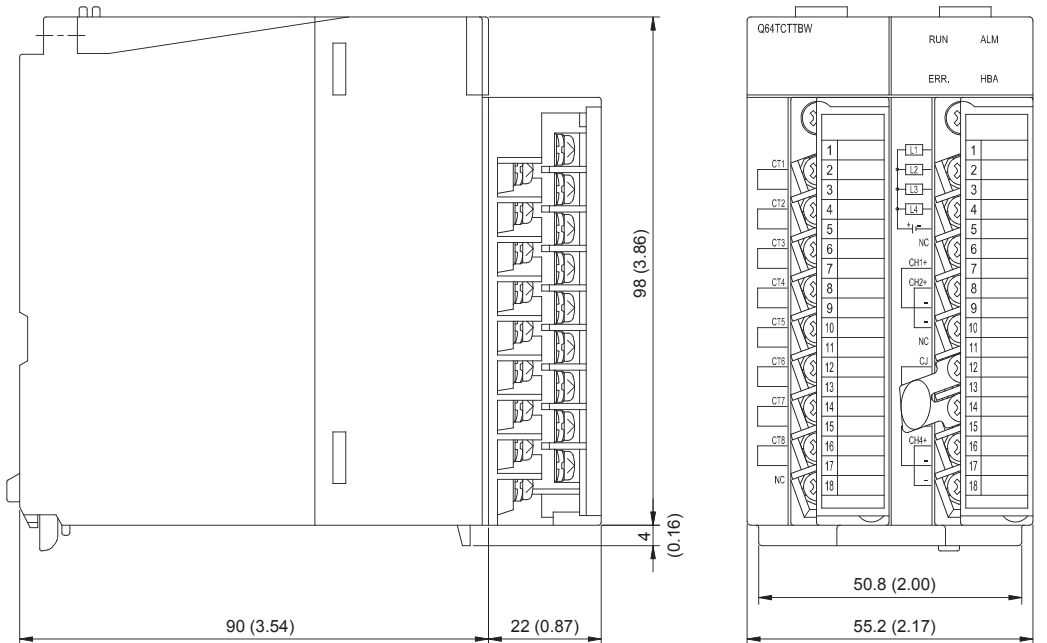

Unit: mm (in.)



(3) Q64TCRT

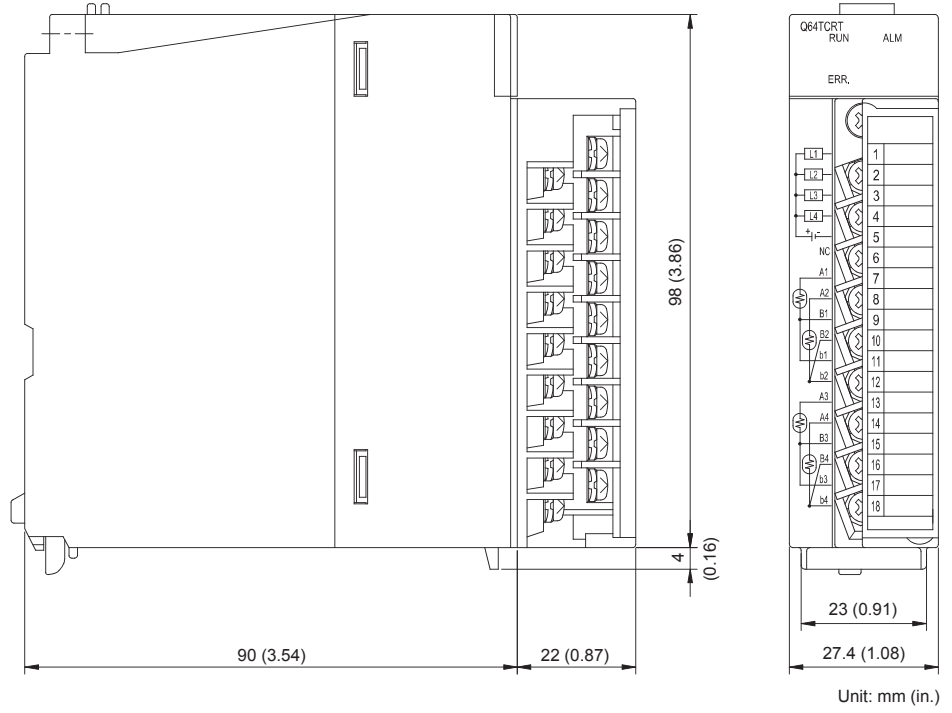

(4) Q64TCRTBW

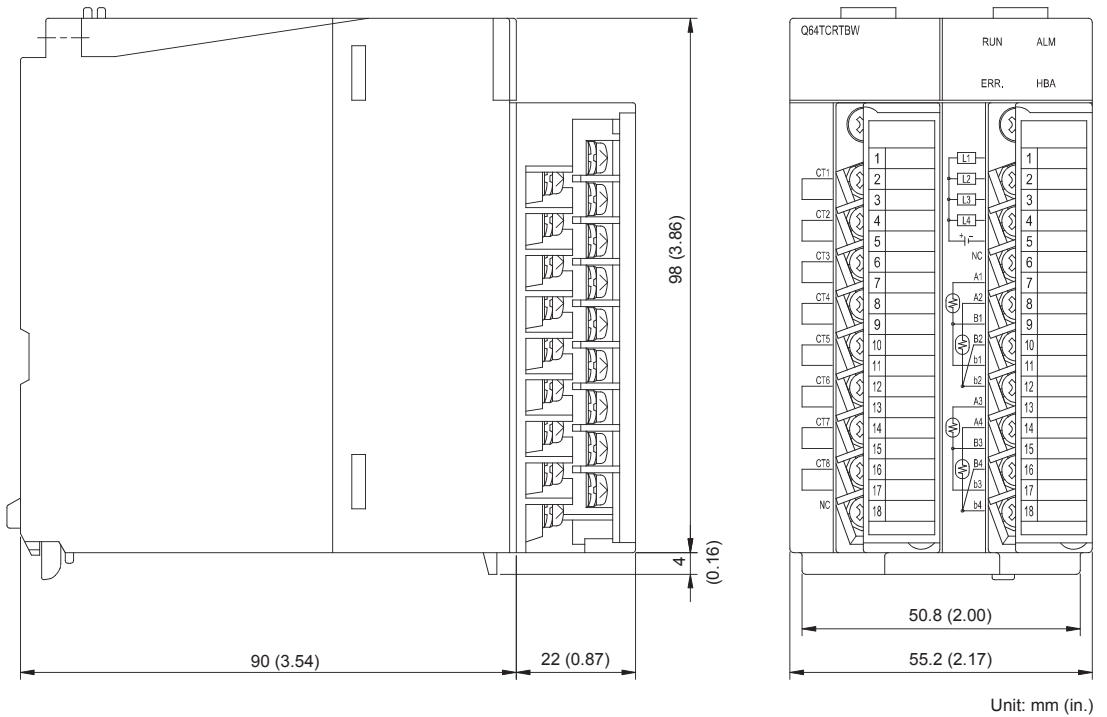

App.

INDEX

- [A]
- Adjustment sensitivity (dead band) setting (buffer memory address: 2EH, 4EH, 6EH, 8EH) 3-48
 - Alert function..... 3-18
 - Alert 1 to 4 mode setting (buffer memory address: C0H to C3H, D0H to D3H, E0H to E3H, F0H to F3H) 3-59
 - Alert set value 1 to 4
(buffer memory address: 26H to 29H, 46H to 49H, 66H to 69H, 86H to 89H)..... 3-45
 - Alert dead band setting (buffer memory address: A4H) 3-56
 - Alert definition (buffer memory address: 5H to 8H) 3-37
 - Alert delay count
(buffer memory address: A5H) 3-56
 - Alert occurrence flag (XnC to XnF)..... 3-28
 - AT bias (buffer memory address: 35H, 55H, 75H, 95H)..... 3-51
 - Auto tuning command (Yn4 to Yn7) 3-29
 - Auto tuning function 3- 5
 - Auto tuning status (Xn4 to Xn7)..... 3-27
 - AUTO/MAN mode switching (buffer memory address: 32H, 52H, 72H, 92H)..... 3-50
 - Auto refresh setting 5-17
- [B]
- Buffer memory list 3-31
- [C]
- Control output period..... 3-24
 - Control output period setting (buffer memory address: 2FH, 4FH, 6FH, 8FH)..... 3-49
 - Control output setting for CPU stop error occurrence..... 3-22
 - Control response parameter (buffer memory address: 31H, 51H, 71H, 91H)..... 3-50
 - Control status 3-23
 - CT input channel assignment setting (buffer memory address: 108H to 10FH)..... 3-60
 - CT monitor method switching (buffer memory address: B0H) 3-58
 - CT selection (buffer memory address: 110H to 117H)..... 3-60
- [D]
- Data resolution 3- 3
 - Data storage on E²PROM 3-16
 - Decimal point position
(buffer memory address: 1H to 4H) 3-36
 - Default setting registration start command (Yn9)..... 3-30
 - Default value write completion flag (Xn9) 3-27
 - Derivative action (D-action) 1-10
- [E]
- E²PROM backup start command (Yn8)..... 3-30
 - E²PROM write completion flag (Xn8)..... 3-27
 - E²PROM write failure flag (XnA) 3-28
 - E²PROM's PID constant read command (buffer memory address: 3EH, 5EH, 7EH, 9EH) 3-55
 - E²PROM's PID constant read/write flag (buffer memory address: 1FH)..... 3-40
 - Error reset command (Yn2)..... 3-29
 - External dimensions Appendix- 1
 - External wiring..... 4- 7
- [F]
- Forced PID control stop 3-11
 - Forced PID control stop command (YnC to YnF) 3-30
 - Forward/reverse action setting (buffer memory address: 36H, 56H, 76H, 96H) 3-53
 - Function list 5- 1
 - Function summary 3- 4
 - Function version..... 1-12, 2-7, 8-6
 - Function Added to Function Version B and Later 1-12
- [G]
- GX Configurator-TC 2-4
 - GX Developer 2-4
- [H]
- Handling precautions 4- 1
 - Hardware error flag (Xn3)..... 3-26
 - Heater current process value (buffer memory address: 100H to 107H) 3-59
 - Heater disconnection alert setting (buffer memory address: 3AH, 5AH, 7AH, 9AH)..... 3-53

Heater disconnection compensation function selection (buffer memory address: AA_H) 3-57
 Heater disconnection detection/compensation function 3-12
 Heater disconnection/output off-time current error detection delay count (buffer memory address: A6_H) 3-56

[I]

I/O signal list 3-25
 Initial settings 5-14
 Input range (buffer memory address: 20_H, 40_H, 60_H, 80_H) 3-42
 Integral action (I-action) 1- 9
 Intelligent function module switch settings ... 4-12
 Internal current consumption 3- 2

[L]

Loop disconnection detection dead band (buffer memory address: 3C_H, 5C_H, 7C_H, 9C_H) 3-54
 Loop disconnection detection function 3-15
 Loop disconnection detection judgment time (buffer memory address: 3B_H, 5B_H, 7B_H, 9B_H) 3-54

[M]

MAN mode shift completion flag (buffer memory address: 1E_H) 3-39
 MAN output setting (buffer memory address: 33_H, 53_H, 73_H, 93_H) 3-51
 Manipulated value (MV) (buffer memory address: B1_H to B4_H) 3-58
 Manipulated value (MV) (buffer memory address: D_H to 10_H) 3-38
 Manipulated value resolution switching (buffer memory address: B5_H) 3-58
 Measured temperature range 3- 3
 Module ready flag (Xn0) 3-26

[O]

Online module change 7- 1
 Output off-time current error detection function 3-15
 Output variation limiter (buffer memory address: 2C_H, 4C_H, 6C_H, 8C_H) 3-48

[P]

Parts identification 4- 3
 PID action 1-11

PID constant setting (buffer memory address: 23_H to 25_H, 43_H to 45_H, 63_H to 65_H, 83_H to 85_H) 3-45
 PID continuation flag (buffer memory address: A9_H) 3-57
 PID control system 1- 5
 PID operation 1- 6
 Primary delay digital filter setting (buffer memory address: 30_H, 50_H, 70_H, 90_H) 3-49
 Procedure before starting the operation 4- 2
 Programming 6- 1
 Proportional action (P-action) 1- 8

[Q]

Q64TCTT (BW) cold junction temperature process value (buffer memory address: 1D_H) 3-39

[R]

Reference heater current value (buffer memory address: 118_H to 11F_H) 3-60
 Reverse/forward action select function 3-10
 RFB limiter function 3-10

[S]

Sampling period 3-24
 Sensor compensation function 3-10
 Sensor compensation value setting (buffer memory address: 2D_H, 4D_H, 6D_H, 8D_H) 3-48
 Set value (SV) (buffer memory address: 22_H, 42_H, 62_H, 82_H) 3-45
 Setting change command (YnB) 3-30
 Setting change completion flag (XnB) 3-28
 Setting change rate limiter (buffer memory address: 34_H, 54_H, 74_H, 94_H) 3-51
 Setting/operation mode command 3-29
 Stop mode setting (buffer memory address: 21_H, 41_H, 61_H, 81_H) 3-44
 System configuration 2- 1

[T]

Temperature process value (PV) (buffer memory address: 9_H to C_H) 3-35
 Temperature rise completion soak time setting (buffer memory address: A8_H) 3-57
 Temperature rise completion range setting (buffer memory address: A7_H) 3-57
 Transistor output monitor ON delay time setting (buffer memory address: A_H) 3-57

Temperature rise judgment flag (buffer memory address: 11H to 14H).....	3-38
Temperature sensor type.....	3- 3
Three-phase heater.....	4-11
Transistor output monitor ON delay time setting (buffer memory address: AFH).....	3-57
Transistor output flag (buffer memory address: 15H to 18H)	3-38
Troubleshooting.....	8- 1

[U]

Unused channel setting	3-11
Unused channel setting (buffer memory address: 3D H, 5D H, 7D H, 9D H)	3-55
Upper/lower output limiter (buffer memory address: 2AH, 2BH, 4AH, 4BH, 6AH, 6BH, 8AH, 8BH).....	3-53
Upper/lower setting limiter (buffer memory address: 37H, 38H, 57H, 58H, 77H, 78H, 97H, 98H).....	3-35
Utility package	5- 1

[W]

Wiring precautions	4- 6
Write data error code (buffer memory address: 0H)	3-35
Write error flag (Xn2).....	3-26

WARRANTY

Please confirm the following product warranty details before using this product.

1. Gratis Warranty Term and Gratis Warranty Range

If any faults or defects (hereinafter "Failure") found to be the responsibility of Mitsubishi occurs during use of the product within the gratis warranty term, the product shall be repaired at no cost via the sales representative or Mitsubishi Service Company.

However, if repairs are required onsite at domestic or overseas location, expenses to send an engineer will be solely at the customer's discretion. Mitsubishi shall not be held responsible for any re-commissioning, maintenance, or testing on-site that involves replacement of the failed module.

[Gratis Warranty Term]

The gratis warranty term of the product shall be for one year after the date of purchase or delivery to a designated place. Note that after manufacture and shipment from Mitsubishi, the maximum distribution period shall be six (6) months, and the longest gratis warranty term after manufacturing shall be eighteen (18) months. The gratis warranty term of repair parts shall not exceed the gratis warranty term before repairs.

[Gratis Warranty Range]

- (1) The range shall be limited to normal use within the usage state, usage methods and usage environment, etc., which follow the conditions and precautions, etc., given in the instruction manual, user's manual and caution labels on the product.
- (2) Even within the gratis warranty term, repairs shall be charged for in the following cases.
 1. Failure occurring from inappropriate storage or handling, carelessness or negligence by the user. Failure caused by the user's hardware or software design.
 2. Failure caused by unapproved modifications, etc., to the product by the user.
 3. When the Mitsubishi product is assembled into a user's device, Failure that could have been avoided if functions or structures, judged as necessary in the legal safety measures the user's device is subject to or as necessary by industry standards, had been provided.
 4. Failure that could have been avoided if consumable parts (battery, backlight, fuse, etc.) designated in the instruction manual had been correctly serviced or replaced.
 5. Failure caused by external irresistible forces such as fires or abnormal voltages, and Failure caused by force majeure such as earthquakes, lightning, wind and water damage.
 6. Failure caused by reasons unpredictable by scientific technology standards at time of shipment from Mitsubishi.
 7. Any other failure found not to be the responsibility of Mitsubishi or that admitted not to be so by the user.

2. Onerous repair term after discontinuation of production

- (1) Mitsubishi shall accept onerous product repairs for seven (7) years after production of the product is discontinued. Discontinuation of production shall be notified with Mitsubishi Technical Bulletins, etc.
- (2) Product supply (including repair parts) is not available after production is discontinued.

3. Overseas service

Overseas, repairs shall be accepted by Mitsubishi's local overseas FA Center. Note that the repair conditions at each FA Center may differ.

4. Exclusion of loss in opportunity and secondary loss from warranty liability

Regardless of the gratis warranty term, Mitsubishi shall not be liable for compensation of damages caused by any cause found not to be the responsibility of Mitsubishi, loss in opportunity, lost profits incurred to the user by Failures of Mitsubishi products, special damages and secondary damages whether foreseeable or not, compensation for accidents, and compensation for damages to products other than Mitsubishi products, replacement by the user, maintenance of on-site equipment, start-up test run and other tasks.

5. Changes in product specifications

The specifications given in the catalogs, manuals or technical documents are subject to change without prior notice.

Microsoft, Windows, Windows NT, and Windows Vista are registered trademarks of Microsoft Corporation in the United States and other countries.

Pentium is a trademark of Intel Corporation in the United States and other countries.

Ethernet is a trademark of Xerox Corporation.

All other company names and product names used in this manual are trademarks or registered trademarks of their respective companies.

SPREAD

Copyright (C) 1996 FarPoint Technologies, Inc.

SH(NA)-080121-O(1507)MEE

MODEL: Q64TCTT/RT-U-S-E

MODEL CODE: 13JR21

MITSUBISHI ELECTRIC CORPORATION

HEAD OFFICE : TOKYO BUILDING, 2-7-3 MARUNOUCHI, CHIYODA-KU, TOKYO 100-8310, JAPAN
NAGOYA WORKS : 1-14, YADA-MINAMI 5-CHOME, HIGASHI-KU, NAGOYA, JAPAN

When exported from Japan, this manual does not require application to the
Ministry of Economy, Trade and Industry for service transaction permission.

Specifications subject to change without notice.